

Shark **DUOCLEAN®** **SLIM UPRIGHT**

with Shark® Self-Cleaning Brushroll
QU201Q Series

OWNER'S GUIDE



duo clean®

IMPORTANT SAFETY INSTRUCTIONS

FOR HOUSEHOLD USE ONLY • PLEASE READ CAREFULLY BEFORE USE

If the plug does not fit fully into the outlet, reverse the plug. If it still does not fit, contact a qualified electrician. DO NOT force into outlet or try to modify to fit.

⚠ WARNING

To reduce the risk of fire, electric shock, injury, or property damage:

GENERAL WARNINGS

1. Your vacuum cleaner may consist of a motorized nozzle, wand, hose, and/or vacuum pod. This device contains electrical connections, electrical wiring, and moving parts that potentially present risk to the user.
2. Use only identical replacement parts.
3. Carefully observe and follow the instructions provided below to avoid improper use of the appliance. **DO NOT** use the vacuum for any purpose other than those described in this manual.
4. Before use, carefully inspect all parts for any damage. **DO NOT** use if any parts are damaged.
5. The use of an extension cord is **NOT** recommended.
6. This vacuum cleaner contains no serviceable parts.

USE WARNINGS

7. **DO NOT** allow the appliance to be used by children. Close supervision is necessary when used near children. This is not a toy.
8. Always turn off the vacuum cleaner before connecting or disconnecting any motorized nozzles or other accessories.
9. **DO NOT** handle plug or vacuum cleaner with wet hands.
10. **DO NOT** use without filters in place.

11. Only use Shark® branded filters and accessories. Failure to do so will also void the warranty.
12. **DO NOT** damage the power cord:
 - a) **DO NOT** pull or carry vacuum cleaner by the cord or use the cord as a handle.
 - b) **DO NOT** unplug by pulling on cord. Grasp the plug, not the cord.
 - c) **DO NOT** run the vacuum cleaner over the power cord, close a door on the cord, pull the cord around sharp corners, or leave the cord near heated surfaces.
13. **DO NOT** put any objects into nozzle or accessory openings. **DO NOT** use with any opening blocked; keep free of dust, lint, hair, and anything that may reduce airflow.
14. **DO NOT** use if nozzle or accessory airflow is restricted. If the air paths or the motorized floor nozzle become blocked, turn the vacuum cleaner off and unplug from electrical outlet. Remove all obstructions before you plug in and turn on the unit again.
15. Keep nozzle and all vacuum openings away from hair, face, fingers, uncovered feet, or loose clothing.
16. **DO NOT** use if vacuum cleaner is not working as it should, or has been dropped, damaged, left outdoors, or dropped into water.

17. Use extra care when cleaning on stairs.
18. **DO NOT** leave the vacuum cleaner unattended while plugged in.
19. When powered on, keep the vacuum cleaner moving over the carpet surface at all times to avoid damaging the carpet fibers.
20. **DO NOT** place vacuum cleaner on unstable surfaces such as chairs or tables.
21. Your Shark® vacuum may not be designed to stand up on its own. When taking a break from cleaning, you may need to lean it against furniture or a wall, or lay it flat on the floor. Using the vacuum for an application where the unit lacks stability may result in personal injury.
22. **DO NOT** use to pick up:
 - a) Liquids
 - b) Large objects
 - c) Hard or sharp objects (glass, nails, screws, or coins)
 - d) Large quantities of dust (drywall dust, fireplace ash, or embers). **DO NOT** use as an attachment to power tools for dust collection.
 - e) Smoking or burning objects (hot coals, cigarette butts, or matches)
 - f) Flammable or combustible materials (lighter fluid, gasoline, or kerosene)
 - g) Toxic materials (chlorine bleach, ammonia, or drain cleaner)

23. **DO NOT** use in the following areas:
 - a) Poorly lit areas
 - b) Wet or damp surfaces
 - c) Outdoor areas
 - d) Spaces that are enclosed and may contain explosive or toxic fumes or vapors (lighter fluid, gasoline, kerosene, paint, paint thinners, mothproofing substances, or flammable dust)
24. Turn off all controls before plugging in or unplugging the vacuum.
25. Unplug from electrical outlet when not in use and before any maintenance or cleaning.
26. Hand wash with water only. Washing with cleaning chemicals could damage the unit.
27. During cleaning or routine maintenance, **DO NOT** cut anything other than hair, fibers, or string wrapped around the brushroll.
28. Allow all filters to air-dry completely before replacing in the vacuum to prevent liquid from being drawn into electric parts.
29. Make sure the dust cup and all filters are in place after routine maintenance.
30. If provided, secure the power cord around the two cord hooks during storage.

To reduce the risk of electric shock, this appliance has a polarized plug (one blade is wider than the other). This plug will fit in a polarized outlet only one way. If the plug does not fit fully in the outlet, reverse the plug. If it still does not fit, contact a qualified electrician to install the proper outlet. Do not change the plug in any way.

SAVE THESE INSTRUCTIONS

ASSEMBLY

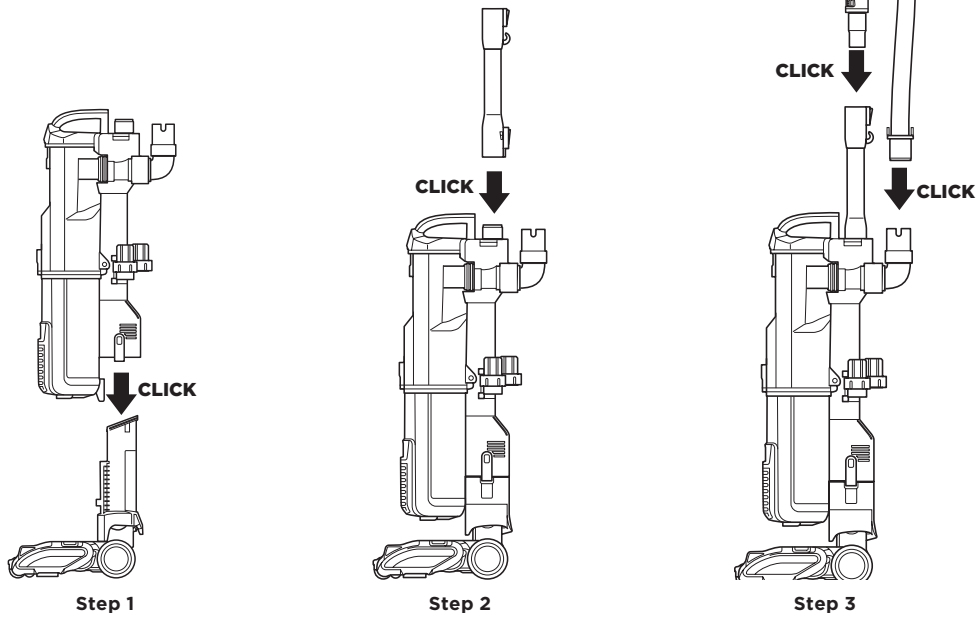

1. Place **Motorized Floor Nozzle** on floor and attach **Pod**, pressing it in until it clicks securely into place.
2. Insert **Wand** into pod, pressing it in until it clicks securely into place.
3. Insert **Handle** into wand, pressing it in until it clicks securely into place.
4. Connect **Hose** into back of pod, pressing it in until it clicks securely into place.

IMPORTANT: For proper operation, ensure all connections are securely clicked into place.

ASSEMBLY

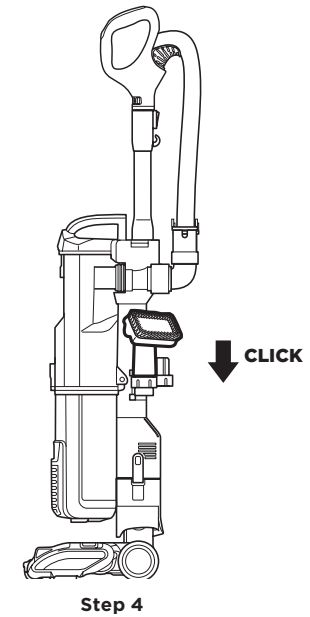

STORAGE

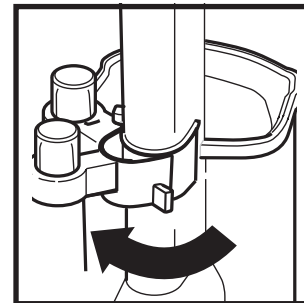

Store tools on the **Accessory Holder**.

To remove the accessory holder, first take off the **Dust Cup**. Then pull out the tab on the right side (when viewing from the back of the vacuum.)

To replace the accessory holder, align the pins into the hinge on the vacuum and clip back into place.

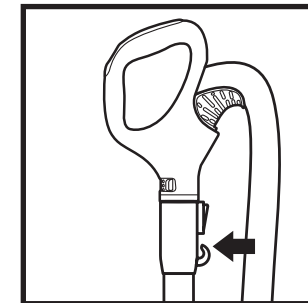

Use cord clip located on the back of wand to hold cord in place while vacuuming.

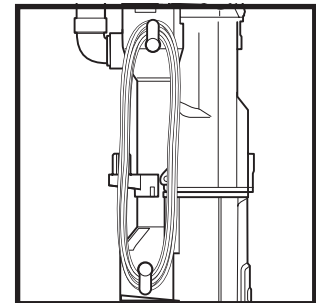

To store your vacuum, wrap cord around cord hooks.

WHOLE-HOME CLEANING

SETTINGS

Push the **POWER** button to turn the vacuum on or off.



In **HARD FLOOR** mode, the **Brushroll** and the **Soft Roller** spin together slowly. The Soft Roller traps fine dust and large particles, while the brushroll directs the debris into the suction channel.

NOTE: The brushrolls will not spin unless the wand is reclined.

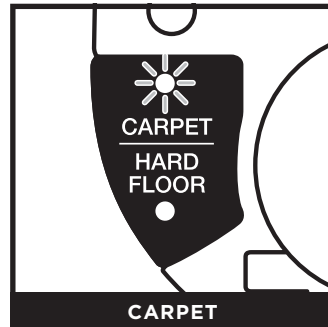

In **CARPET** mode, both brushrolls spin faster, working together to pick up debris below the surface of your carpets.

NOTE: The brushrolls will not spin unless the wand is reclined.

WHOLE-HOME CLEANING

CLEANING MODES

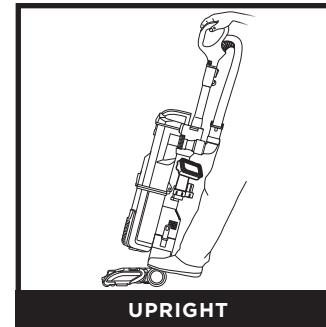

To engage brushrolls, turn power on, then step on floor nozzle and tilt handle back.



Press the **Handle Release Latch** to detach the handle from the wand.

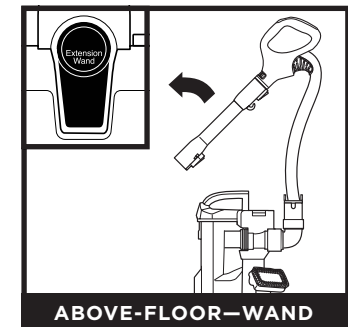

Press the **Extension Wand Release** button to detach the wand from the pod.

SUCTION CONTROL

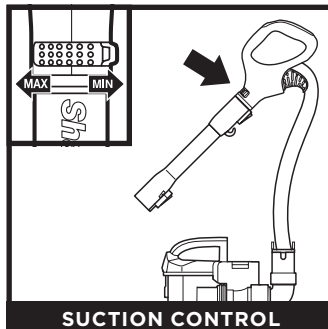

To reduce suction for more maneuverability on carpets, slide **Suction Control** to **MIN**. Slide to **MAX** for more suction on bare floors.

BRUSHROLL INDICATOR LIGHT

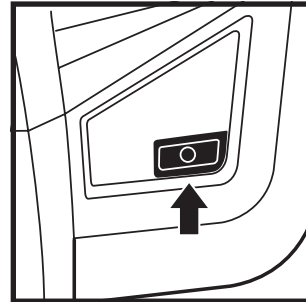

WHAT DOES THE BRUSHROLL INDICATOR LIGHT MEAN?

Solid Green: The brushroll and Soft Roller are spinning and working properly.

Solid Red: There is a jam in the brushroll area. Turn your vacuum off and remove any blockages in the nozzle.

Flashing Red: The motorized floor nozzle is overheating. Turn off your vacuum and wait for it to cool down. After vacuum has cooled, move surface selector switch to Carpet setting, then press the selector button to turn vacuum back on.

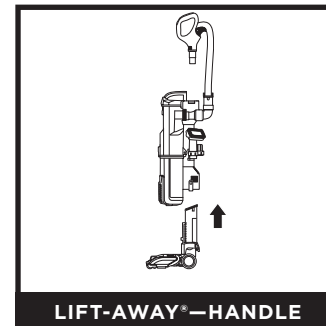

Remove the wand from the pod and the handle (see above). Press the **Lift-Away** button to detach the pod from the floor nozzle. Attach a cleaning accessory to the handle.

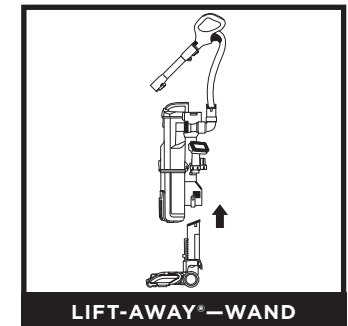

Detach wand from pod (see above). Press the **Lift-Away** button to detach the pod from the floor nozzle. Attach a cleaning accessory to the end of the wand.

NOTE: For deep cleaning per ASTM F 608 (embedded dirt in carpets) please set to **Carpet**. **NOTE:** For particularly stubborn stuck-on dust messes on hard floors, set to **Carpet**.

NOTE: All accessories are compatible with both the wand and the handle.

EMPTYING THE DUST CUP

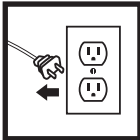

IMPORTANT: Unplug the power cord before performing any maintenance.

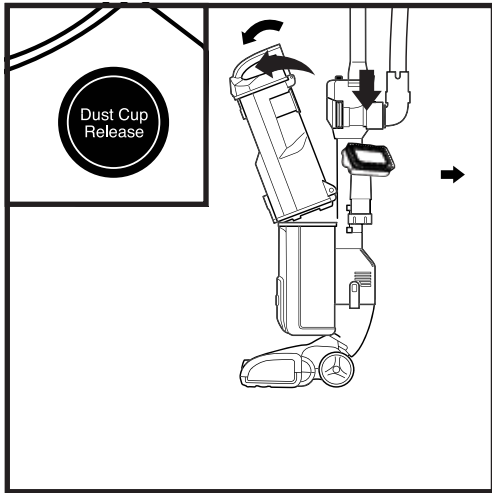

To remove **Dust Cup**, press the **Dust Cup Release Button** and lift dust cup off the vacuum.

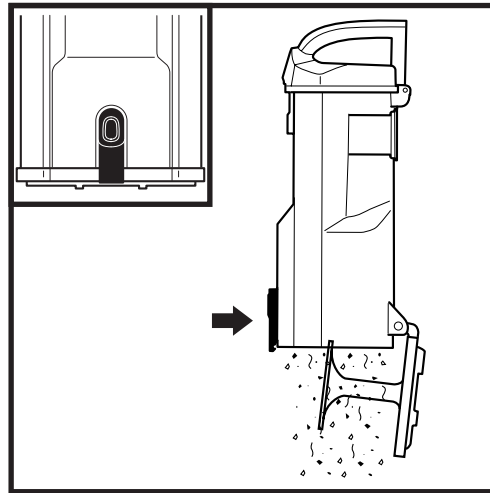

To empty debris, press lower release button and bottom of dust cup will drop open.

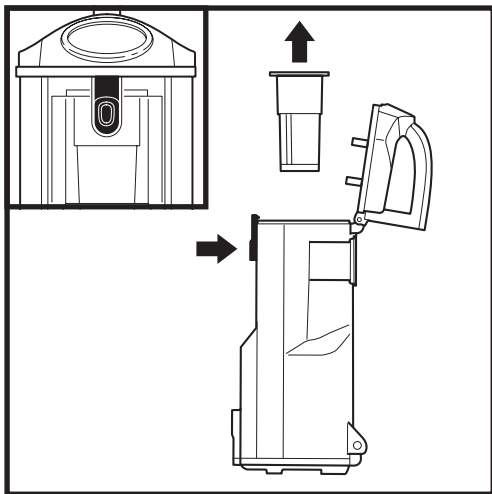

To remove collected debris from **Lint Screen**, press top release button and lift handle to open. Gently brush lint screen to clean.

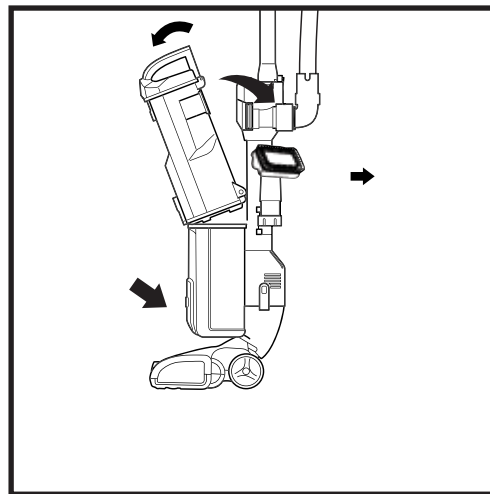

To reinstall, place bottom of dust cup into pod and then tilt until it clicks into place.

CLEANING AND REPLACING THE FILTERS

CLEANING FILTERS

Regularly clean and replace the filters to keep your vacuum's suction power optimal.

To clean filters, rinse with cold water **ONLY** to prevent damage from cleaning chemicals. Allow all filters to air-dry for at least 24 hours before reinstalling them to prevent liquid from being drawn into electric parts.

IMPORTANT: DO NOT use soap when cleaning the filters.

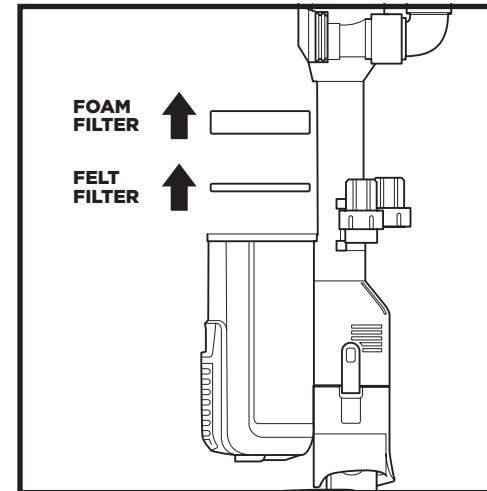

CLEAN PRE-MOTOR FILTERS EVERY MONTH

Remove **Dust Cup**, then lift out **Filters**. Tap loose dirt off filters between washes as needed.

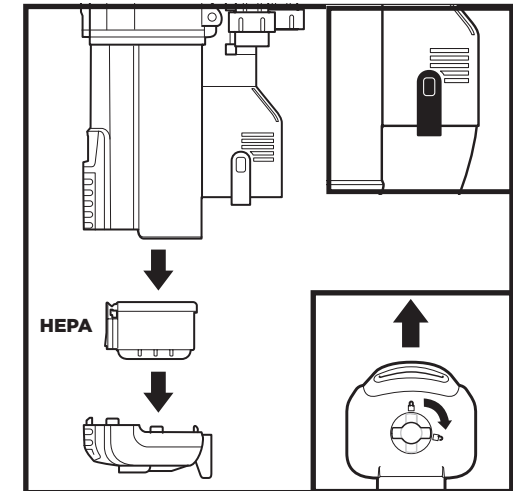

CLEAN HEPA FILTER EVERY YEAR

To access the **HEPA Filter**, remove the floor nozzle by pressing the **Nozzle Release Button** on the side of the vacuum. To release the filter frame, turn latch to the unlock symbol. Press the tab on the HEPA filter to remove, then rinse the filter with water. Be sure to let all filters air-dry completely before reinstalling.

REPLACING FILTERS

Follow the previous instructions for removing filters. The **Pre-Motor Filter** should be replaced every 2.5 years. The **HEPA Filter** should be replaced every 3 years.

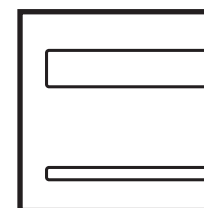

Replacement Pre-Motor Foam & Felt Filter Kit
XFF450

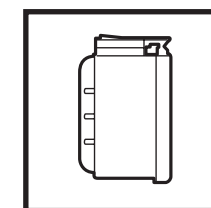

Replacement HEPA Filter
XHF450

NOTE: To order replacement parts and filters, visit sharkaccessories.com.

MAINTENANCE

CLEANING OR REPLACING THE SELF-CLEANING BRUSHROLL

BRUSHROLL

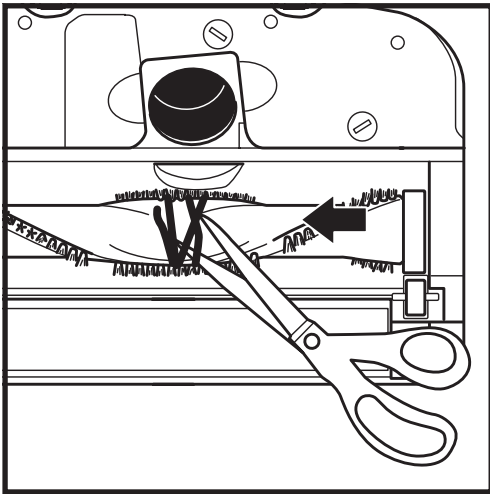
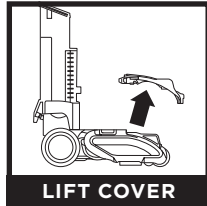
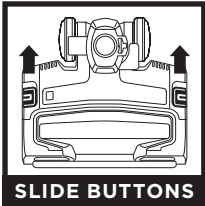

1. Push up both sliders on floor nozzle at the same time to pop up the brushroll garage lid.
2. To remove any string, hair, or debris that may be wrapped around the brushroll, use scissors to cut along the groove in the brushroll.

NOTE: If any hair is wrapped around the brushroll, extending cleaning time will allow the self-cleaning brushroll to remove it for you. If some fibers remain wrapped around brushroll after continued use, carefully cut debris with scissors and remove it.

SOFT ROLLER

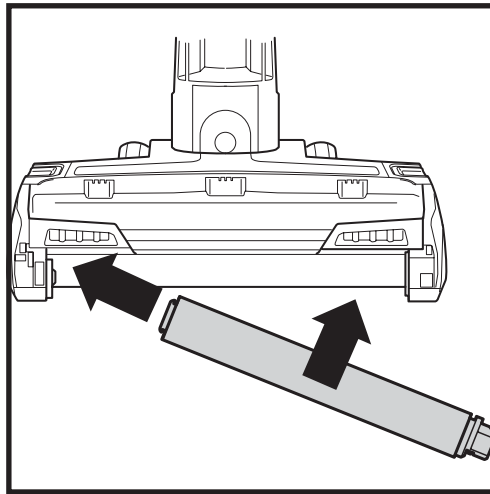
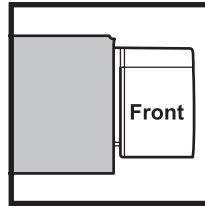
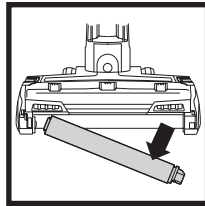

1. Push up both sliders on floor nozzle at the same time to pop up the brushroll garage lid.
2. To remove **Soft Roller** from nozzle, lift it out by the pull tab on the right side.
3. You can also tap loose debris off the Soft Roller, or wipe it clean with a dry towel. If you see any hair buildup or fibers caught in the teeth behind the Soft Roller, wipe clean with a dry towel.
4. Wash the Soft Roller as needed. Use only water, and let air-dry completely for at least 24 hours.
5. Reinsert Soft Roller until it is secured, then place the garage door lid onto the nozzle and press down until it securely clicks in place on both sides.

NOTE: To order replacement parts and filters, visit sharkaccessories.com.

CHECKING FOR BLOCKAGES

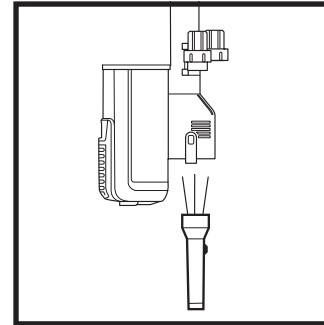

Detach floor nozzle from vacuum pod, and check opening on bottom of pod for blockages.

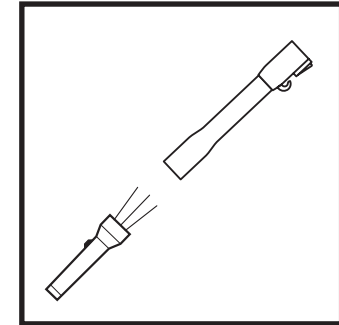

Detach wand from floor nozzle and handle, and check both ends for blockages.

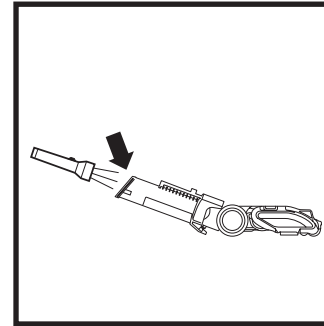

Detach wand from floor nozzle, tilt nozzle neck back, and check opening for blockages.

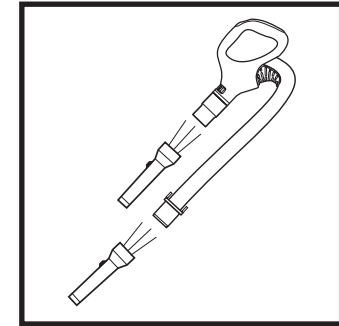

Detach handle from wand and hose from the vacuum pod, and check openings for blockages.

- A 8" Crevice Tool** (255FLIH380)
- B 12" Crevice Tool** (248FLIH200)
- C 18" Flexi Crevice Tool** (1352FC200)
- D Flexible Hose** (1356FC200)
- E Duster Crevice Tool** (249FLIH200)
- F Dusting Brush** (250FLIH200)
- G Multi-Angle Dusting Brush** (1354FC200)
- H Anti-Allergen Dust Brush** (233FLIH100)
- I Upholstery Tool** (251FLIH200)
- J Wide Upholstery Tool** (1355FC200)
- K Pet Multi-Tool** (1353FC200)
- L MultiFLEX® Under-Appliance Wand** (234FLIH100)
- M Home & Car Detail Kit** (XHMC380)
- N Precision Duster** (XDET380)
- O Accessory Bag** (XBGV300)

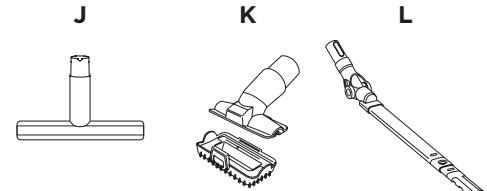
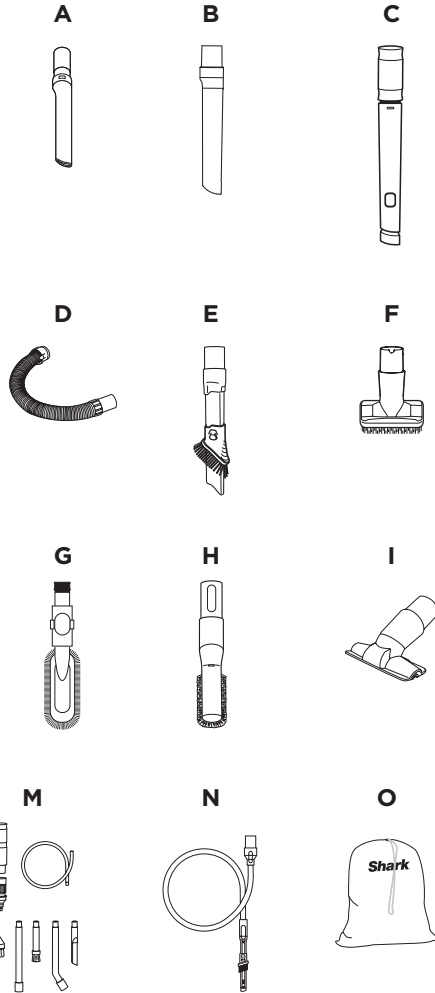

NOTE: Not all accessories come with all units. Please see the enclosed Quick Start Guide for your unit's configuration. To order additional accessories, visit sharkaccessories.com.

Vacuum is not picking up debris. No suction or light suction.

- Check filters to see if they need cleaning. Follow instructions for rinsing and air-drying the filters before reinserting in the vacuum.
- Dust cup may be full; empty dust cup.
- Check hose, hose connections, nozzle, wand, pod, and accessories for blockages. Clear any blockages found.

(Refer to Checking for Blockages section for more information.)

- If any hair, string, or carpet fibers are wrapped around the brushroll, extend cleaning time to allow the self-cleaning brushroll to remove them.
 - If some hair or fibers remain wrapped around brushroll after continued use, remove the brushroll garage lid and carefully cut them away. See Cleaning the Brushroll section for more information.

Vacuum lifts area rugs.

- Make sure selector button is set to Hard Floor.
- Suction is powerful. Take care when vacuuming area rugs or rugs with delicately sewn edges.
- To minimize suction, slide the Suction Control to MIN.

Brushrolls do not spin.

- If the Brushroll Indicator Light turns red, immediately turn off and unplug the vacuum. Remove pod from floor nozzle and clear any blockages. Reconnect nozzle, plug in vacuum, and turn on power.
- With the power on, recline the handle, which will automatically activate the brushrolls.
- Ensure that the selector button is set to Carpet for brushrolls to spin.
- If Brushroll Indicator Light is green and headlights are flashing, remove brushroll garage lid and re-install until you hear a click from both sides.

Vacuum turns off on its own or indicator light flashes red.

This vacuum is equipped with a motor-protective thermostat. If your vacuum overheats, the thermostat will automatically turn the suction motor off. Perform the following steps to restart the thermostat:

1. Turn vacuum off and unplug it.
2. Empty dust cup and clean filters.
3. Check for blockages in hose, accessories, and inlet openings.
4. Allow unit to cool for a minimum of 45 minutes.
5. Plug in the vacuum and turn it on.

FIVE (5) YEAR LIMITED WARRANTY

The Five (5) Year Limited Warranty applies to purchases made from authorized retailers of **SharkNinja Operating LLC**. Warranty coverage applies to the original owner and to the original product only and is not transferable.

SharkNinja warrants that the unit shall be free from defects in material and workmanship for a period of five (5) years from the date of purchase when it is used under normal household conditions and maintained according to the requirements outlined in the Owner's Guide, subject to the following conditions and exclusions:

What is covered by this warranty?

1. The original unit and/or non-wearable components deemed defective, in SharkNinja's sole discretion, will be repaired or replaced up to five (5) years from the original purchase date.
2. In the event a replacement unit is issued, the warranty coverage ends six (6) months following the receipt date of the replacement unit or the remainder of the existing warranty, whichever is later. SharkNinja reserves the right to replace the unit with one of equal or greater value.

What is not covered by this warranty?

1. Normal wear and tear of wearable parts (such as foam filters, HEPA filters, pads, etc.), which require regular maintenance and/or replacement to ensure the proper functioning of your unit, are not covered by this warranty. Replacement parts are available for purchase at **sharkaccessories.com**.
2. Any unit that has been tampered with or used for commercial purposes.
3. Damage caused by misuse (e.g., vacuuming up water or other liquids), abuse, negligent handling, failure to perform required maintenance (e.g., not cleaning the filters), or damage due to mishandling in transit.
4. Consequential and incidental damages.
5. Defects caused by repair persons not authorized by SharkNinja. These defects include damages caused in the process of shipping, altering, or repairing the SharkNinja product (or any of its parts) when the repair is performed by a repair person not authorized by SharkNinja.
6. Products purchased, used, or operated outside North America.

How to get service

If your appliance fails to operate properly while in use under normal household conditions within the warranty period, visit **sharkclean.com/support** for product care and maintenance self-help. Our Customer Service Specialists are also available at **1-800-798-7398** to assist with product support and warranty service options, including the possibility of upgrading to our VIP warranty service options for select product categories.

SharkNinja will cover the cost for the customer to send in the unit to us for repair or replacement. A fee of \$24.95 (subject to change) will be charged when SharkNinja ships the repaired or replacement unit.

How to initiate a warranty claim

You must call **1-800-798-7398** to initiate a warranty claim. You will need the receipt as proof of purchase. A Customer Service Specialist will provide you with return and packing instruction information.

How state law applies

This warranty gives you specific legal rights, and you also may have other rights that vary from state to state. Some states do not permit the exclusion or limitation of incidental or consequential damages, so the above may not apply to you.

REGISTER YOUR PURCHASE



registryourshark.com



Scan QR code using mobile device



Benefits of registering your product and creating an account:

- Get easier, faster product support and access to warranty information
- Access troubleshooting and product care instructions
- Be among the first to know about exclusive product promotions

TIP: You can find the model and serial numbers on the QR code label on the bottom of the back of the vacuum pod.

RECORD THIS INFORMATION

Model Number: _____

Serial Number: _____

Date of Purchase: _____
(Keep receipt)

Store of Purchase: _____

TECHNICAL SPECIFICATIONS

Voltage: 120V, 60Hz

Watts: 650W

Amps: 5.4A

PLEASE READ CAREFULLY AND KEEP FOR FUTURE REFERENCE.

This Owner's Guide is designed to help you get a complete understanding of your new Shark® DuoClean® Slim Upright Vacuum with Self-Cleaning Brushroll.

SharkNinja Operating LLC
US: Needham, MA 02494
CAN: Ville St-Laurent, QC H4S 1A7
1-800-798-7398
sharkclean.com

Illustrations may differ from actual product. We are constantly striving to improve our products; therefore the specifications contained herein are subject to change without notice.

For SharkNinja U.S. Patent information, visit sharkninja.com/uspatents