

# ***Shark*** **ROTATOR™ / MC**

**NV681**

---

## **INSTRUCTIONS**



 [sharkclean.com](http://sharkclean.com)

 1-800-798-7398

# THANK YOU

for purchasing the Shark® Rotator™ Powered Lift-Away™ Speed

---

## REGISTER YOUR PURCHASE

 sharkclean.com

 1-800-798-7398



**TIP:** You can find the model number on the rating label located on the back of your unit.



**TIP:** You can locate the date code on one of the prongs of the power cord plug.

## RECORD THIS INFORMATION

Model Number: \_\_\_\_\_

Date Code: \_\_\_\_\_

Date of Purchase (Keep receipt): \_\_\_\_\_

Store of Purchase: \_\_\_\_\_

## TECHNICAL SPECIFICATIONS

Voltage: 120V., 60Hz

Watts: 800W

Amps: 6.7A

## PLEASE READ CAREFULLY AND KEEP FOR FUTURE REFERENCE.

This Owner's Guide is designed to help you get a complete understanding of your new Shark Rotator Powered Lift-Away Speed.

If you should have a question, please call the customer service line at 1-800-798-7398.

# CONTENTS

---

<b>Important Safety Instructions</b> .....	<b>3</b>
<b>Getting to Know Your Shark® Rotator Powered Lift-Away™ Speed</b> .....	<b>5</b>
<b>Assembling Your Vacuum</b> .....	<b>7</b>
<b>Using Your Vacuum in Upright Mode</b> .....	<b>9</b>
What Does the Brushroll Indicator Light Mean? .....	9
<b>Using Your Vacuum in Above-Floor Mode</b> .....	<b>11</b>
The Benefits of Suction Control .....	11
<b>Changing Your Floor Nozzles</b> .....	<b>13</b>
Motorized Floor Nozzle .....	13
Dust-Away™ .....	13
<b>Using Your Vacuum in Powered Lift-Away Mode</b> .....	<b>15</b>
Powered Lift-Away Cleaning .....	15
Lift-Away™ Cleaning .....	16
<b>Compatible Accessories</b> .....	<b>17</b>
<b>Maintenance</b> .....	<b>19</b>
Emptying the Dust Cup .....	19
Cleaning the Filters .....	20
Checking for Blockages & Maintaining Brushroll.....	21
<b>Troubleshooting Guide</b> .....	<b>23</b>
<b>Warranty</b> .....	<b>24</b>

# IMPORTANT SAFETY INSTRUCTIONS

## FOR HOUSEHOLD USE ONLY

---

### **⚠ WARNING**

**To reduce the risk of injury, fire, electric shock, and property damage resulting from improper use of the appliance, carefully observe the following instructions. This unit contains electrical connections and moving parts that potentially present risk to the user.**

#### **THE POWER NOZZLE, WAND, AND HANDLE CONTAIN ELECTRICAL CONNECTIONS:**

- These are not serviceable parts.
  - Do not use to vacuum any liquids.
  - Do not immerse in water.
  - If handle/wand is damaged, discontinue use.
- .....

- 1** Inspect power cord or plug for any damage before use. **DO NOT** use vacuum cleaner with a damaged cord or plug. Turn off all controls before plugging or unplugging the vacuum cleaner. Store your vacuum cleaner with the power cord secured around the two cord hooks.
- 2** **DO NOT** use outdoors or on wet surfaces. Use only on dry surfaces.
- 3** Unplug from electrical outlet when not in use and before servicing.
- 4** If vacuum cleaner is not working as it should, has been dropped, damaged, left outdoors, or dropped into water, return it to SharkNinja Operating LLC for examination, repair, or adjustment.
- 5** The hose contains electrical wires. **DO NOT** use when damaged, cut, or punctured.
- 6** **DO NOT** pull or carry vacuum cleaner by the cord or use the cord as a handle.
- 7** **DO NOT** unplug by pulling on cord. Grasp the plug, not the cord.
- 8** **DO NOT** handle plug or vacuum cleaner with wet hands.

- 9** **DO NOT** run the vacuum cleaner over the power cord, close a door on the cord, or pull cord around sharp corners.
- 10** The use of an extension cord is **NOT** recommended.
- 11** **DO NOT** leave vacuum cleaner unattended when plugged in.
- 12** Keep cord away from heated surfaces.
- 13** Always turn off the vacuum cleaner before connecting or disconnecting motorized nozzle.

#### **GENERAL USE**

- 14** Use only as described in this manual.
- 15** Keep your work area well lit.
- 16** Keep the vacuum cleaner moving over the carpet surface at all times to avoid damaging the carpet fibers.
- 17** **DO NOT** place vacuum cleaner on unstable surfaces such as chairs or tables.
- 18** **DO NOT** put any objects into openings. **DO NOT** use with any opening blocked; keep free of dust, lint, hair, and anything that may reduce airflow.
- 19** **DO NOT** allow the appliance to be used by children. Close attention is necessary when used near children. This is not a toy.
- 20** **DO NOT** use without dust cup and/or filters in place.

# SAVE THESE INSTRUCTIONS

PLEASE READ CAREFULLY BEFORE USE

## DUST CUP/FILTERS/ACCESSORIES

Before turning on the vacuum:

- 21** Make sure that all filters are thoroughly dry after routine cleaning.
- 22** Make sure that dust cup and all filters are in place after routine maintenance.
- 23** Make sure accessories are free of blockages.
- 24** Only use Shark-brand filters and accessories (failure to do so will void the warranty).

## HOSE ATTACHMENTS

- 25** DO NOT use if airflow is restricted; if the air paths or the motorized floor nozzle become blocked, turn the vacuum cleaner off and unplug from electrical outlet. Remove all obstructions before you turn on the unit again.
- 26** Keep the end of the hose and accessory openings away from face and body.
- 27** Keep cleaning tools and hose suction openings away from hair, face, fingers, uncovered feet, or loose clothing.
- 28** Only use manufacturer's recommended attachments.

## GENERAL CLEANING

- 29** DO NOT pick up large-sized objects.
- 30** DO NOT pick up hard or sharp objects such as glass, nails, screws, or coins that could damage the vacuum cleaner.

- 31** DO NOT use to pick up drywall dust, fireplace ash, or embers. DO NOT use as an attachment to power tools for dust collection.
- 32** DO NOT pick up smoking or burning objects such as hot coals, cigarette butts, or matches.
- 33** DO NOT pick up flammable or combustible materials (e.g., lighter fluid, gasoline, or kerosene) or use vacuum in areas where they may be present.
- 34** DO NOT pick up toxic solutions (e.g., chlorine bleach, ammonia, or drain cleaner).
- 35** DO NOT use in an enclosed space where vapors are present from paint, paint thinner, moth-proofing substances, flammable dust, or other explosive or toxic materials.
- 36** DO NOT vacuum up any liquids.
- 37** DO NOT immerse vacuum cleaner in water or other liquids.
- 38** Use extra care when cleaning on stairs.

## POLARIZED PLUG

To reduce the risk of electric shock, this vacuum cleaner has a polarized plug (one blade is wider than the other). As a safety feature, this plug will fit into a polarized outlet only one way. If the plug does not fit fully into the outlet, reverse the plug. If it still does not fit, contact a qualified electrician. DO NOT force into outlet or try to modify to fit.

# GETTING TO KNOW YOUR SHARK® ROTATOR™ POWERED LIFT-AWAY™ SPEED

---

## WELCOME!

Congratulations on your purchase. Use this instruction manual to learn about your new vacuum's great features. From assembly to use to maintenance, you will find it all in here.

## MAIN UNIT

- A** Surface Selector
- B** Handle Release Button
- C** Suction Control Slide
- D** Power Switch
- E** Hose
- F** Hose Clip
- G** Upper Cord Hook
- H** Lift-Away Button
- I** Wand Release Button
- J** Lift-Away Pod
- K** Wand
- L** Lower Cord Hook
- M** Motorized Floor Nozzle
- N** Brushroll Indicator Light
- O** Headlights

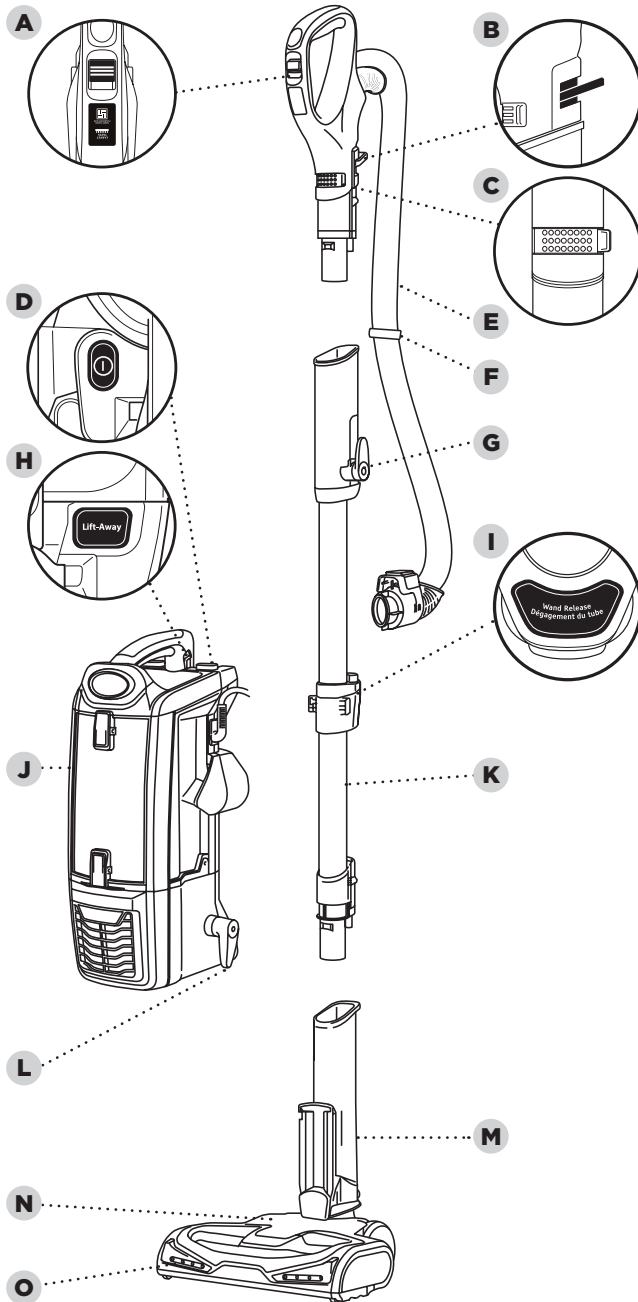

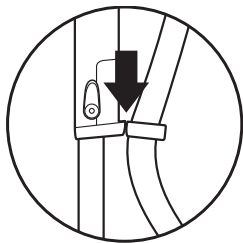

# ASSEMBLING YOUR VACUUM

 **TIP:** Slide hose clip into back of wand for convenience.

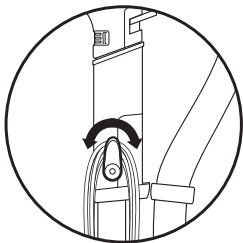

 **TIP:** For quick cord access, rotate upper hook down and remove cord.



 **TIP:** To store your vacuum, wrap cord around cord hooks.

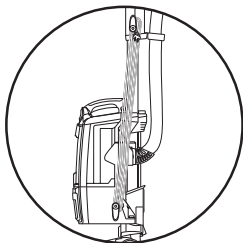

## STEP 1

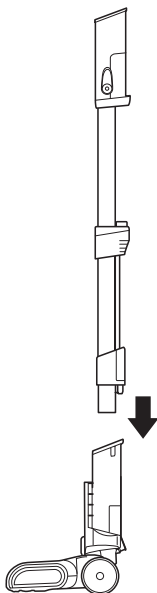

## STEP 2

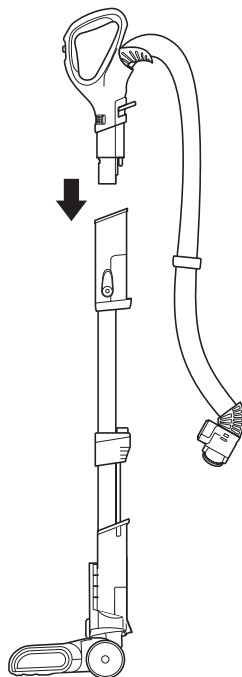

- 1** Place selected floor nozzle on floor and insert wand.
- 2** Insert handle into wand.

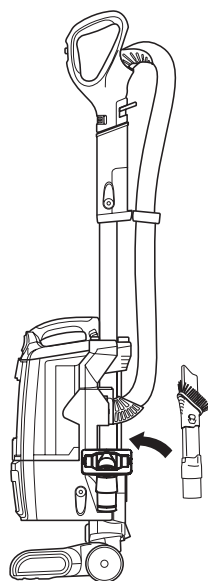
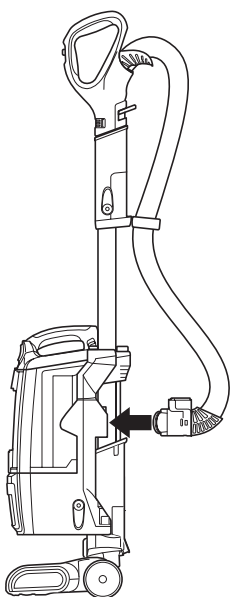
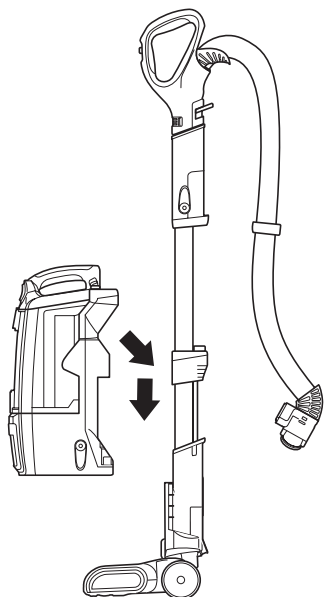

**STEP 3****STEP 4****STEP 5**

- 3** Place pod onto wand and slide down to connect.
- 4** Connect hose into back of pod until you hear a click.
- 5** Place duster crevice and pet multi-tool on their accessory posts.

# USING YOUR VACUUM IN UPRIGHT MODE

**⚠ WARNING: DO NOT use to pick up drywall dust, fireplace ash, or embers. DO NOT use as an attachment to power tools for dust collection.**

## WHAT DOES THE BRUSHROLL INDICATOR LIGHT MEAN?

### **Solid Green**

The brushroll is on and working as it should.

### **Solid Red**

There is a jam in the brushroll area. Turn your vacuum off and remove the blockage.

### **Flashing Red\***

The motorized floor nozzle is overheating. Turn your vacuum off and wait for it to cool down. Next time you are vacuuming that surface, try opening the Suction Control.

### **No Light**

The brushroll is off because the vacuum is in Hard Floor mode.

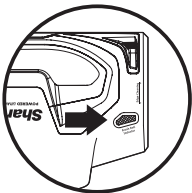

\*See Troubleshooting section for further instructions.

## STEP 1

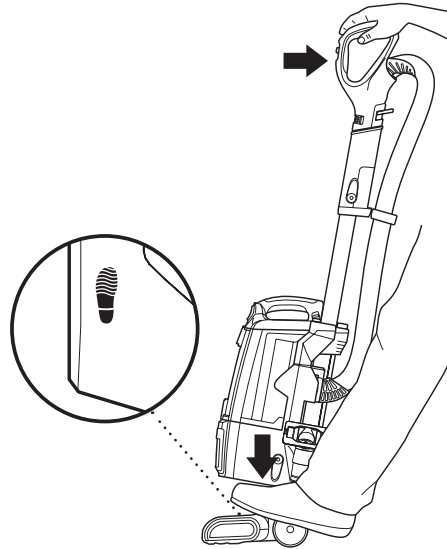

- 1 Plug power cord into outlet. Place foot on floor nozzle and tilt handle back.

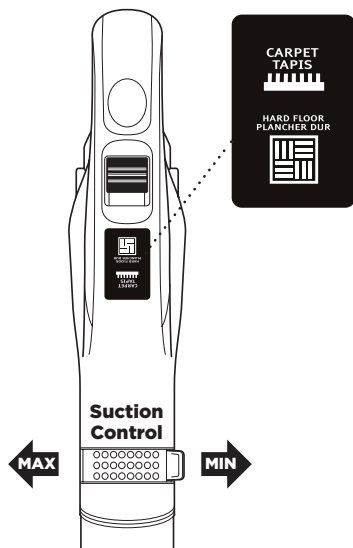
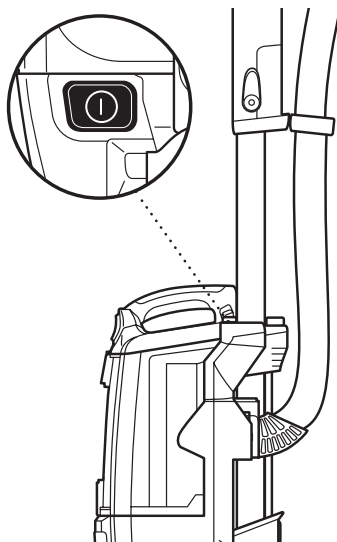
**STEP 2****STEP 3**

- 2** Choose the appropriate setting.

**Hard Floor Cleaning**

Set floor selector to Hard Floor and adjust suction control as needed.

**Thick Carpet & Area Rug Cleaning**

Set floor selector to Carpet and adjust suction control as needed.

**Carpet Cleaning**

Set floor selector to Carpet and adjust suction control as needed.

**NOTE:** For deep cleaning per ASTM F 608 (embedded dirt in carpets) please set to Carpet and Suction Control to MAX.

- 3** Press power button to turn vacuum on to start cleaning. Please note the brushroll will not spin unless the wand is reclined.

# USING YOUR VACUUM IN ABOVE-FLOOR MODE

## THE BENEFITS OF SUCTION CONTROL

Suction Control is a way for you to adjust suction power when you are using different tools or vacuuming different surfaces. For example, if you are feeling resistance vacuuming thick carpet or upholstery, opening the suction control to MIN will help reduce your push/pull effort.

## STEP 1

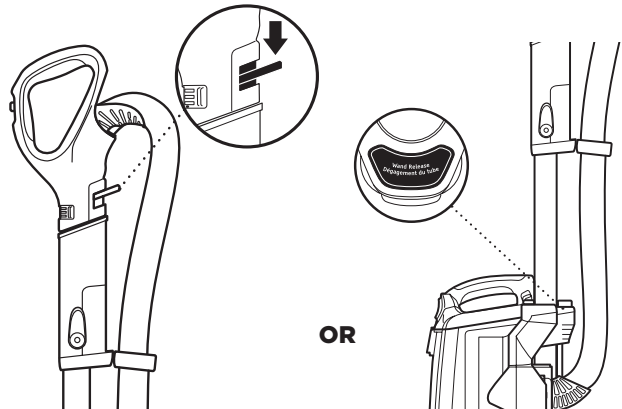

- 1** Press the Handle Release button when you need to clean within short reach. **OR** Press the Wand Release button when you need to clean with a longer reach.

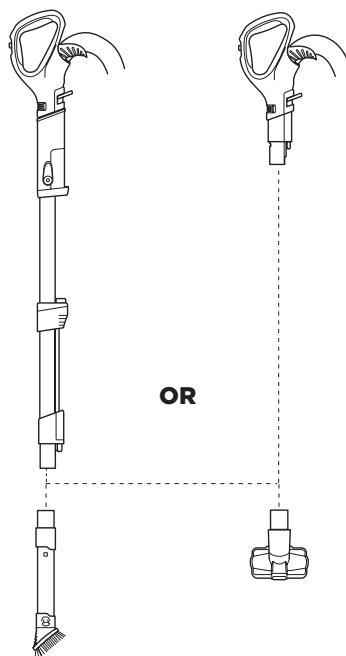
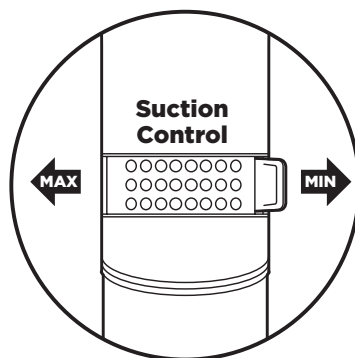
**STEP 2****STEP 3**

**2** Insert desired tool directly onto wand or handle.

**3** Suction Control offers variable suction based on your needs. Slide toward MIN to minimize suction, and slide toward MAX to maximize suction.

# CHANGING YOUR FLOOR NOZZLES

If your vacuum comes with a Dust-Away™ Pro, use these instructions.

To purchase a Dust-Away Pro, go to [sharkclean.com](http://sharkclean.com)

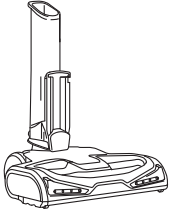

**Motorized Floor Nozzle**

Use the motorized floor nozzle for deep-cleaning carpets and picking up large debris on hard floors.

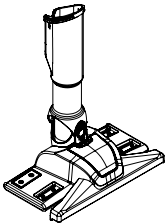

**Dust-Away Hard Floor Attachment**

Use the Dust-Away Hard Floor Attachment to pick up debris and wipe away fine dust on hard floors.

.....  
★ **IMPORTANT:** Do not use the Dust-Away Hard Floor Attachment without the microfiber pad attached.

## STEP 1

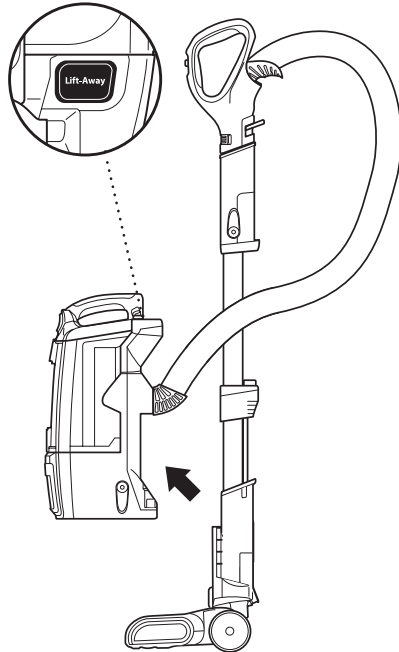

- 1 Press Lift-Away™ button to lift pod off motorized floor nozzle.

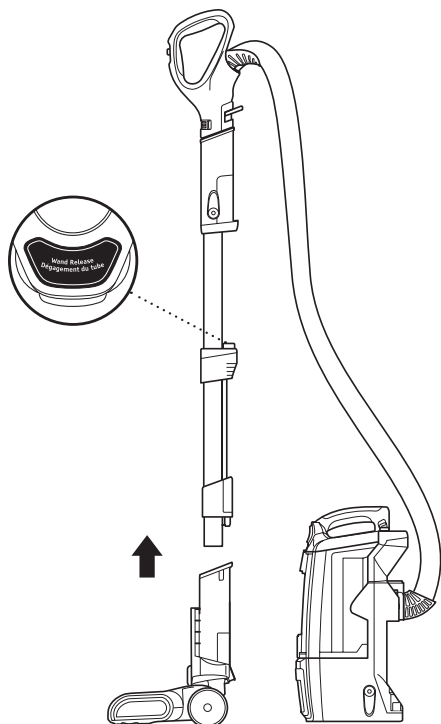
**STEP 2**

- 2** Press Wand Release button to remove wand from motorized floor nozzle.

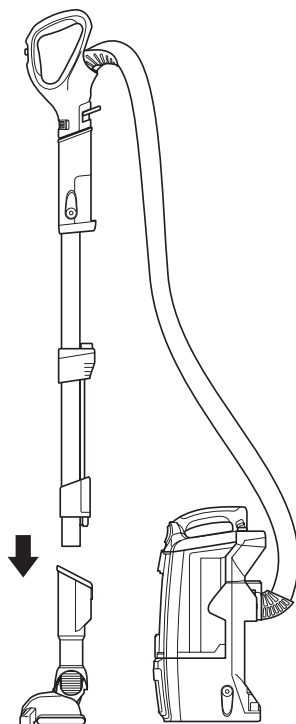
**STEP 3**

- 3** Insert wand into the Dust-Away™ Hard Floor Attachment.

Hold pod in hand to clean in Lift-Away™ mode. You cannot use the Dust-Away Hard Floor Attachment in regular upright mode.

# USING YOUR VACUUM IN POWERED LIFT-AWAY MODE

**⚠ WARNING: Ensure solid footing when using in Lift-Away mode.** Using for an application where you lack stability may result in personal injury.

**👉 NOTE:** You can use the Powered Lift-Away feature with either floor nozzle.

## WHAT IS POWERED LIFT-AWAY?

Our Powered Lift-Away feature allows you to remove the pod from the nozzle while maintaining the same power you have in upright mode. This is great for cleaning stairs, under furniture, and in other tight spaces.

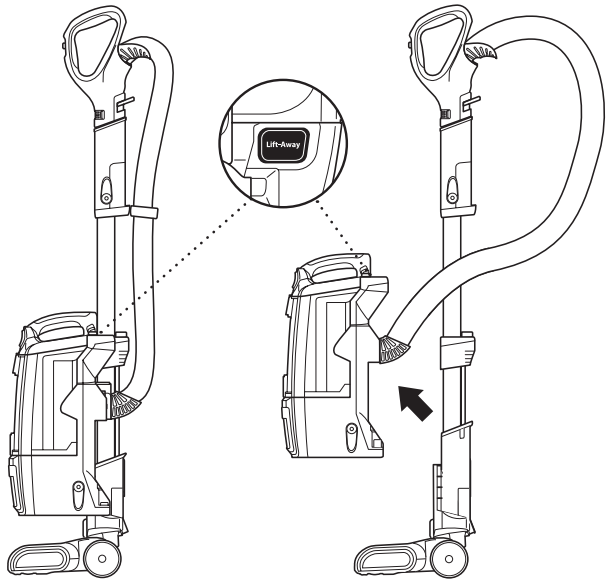

## POWERED LIFT-AWAY CLEANING

- 1 Press Lift-Away button to lift pod off floor nozzle. You are now ready to clean those hard-to-reach places.



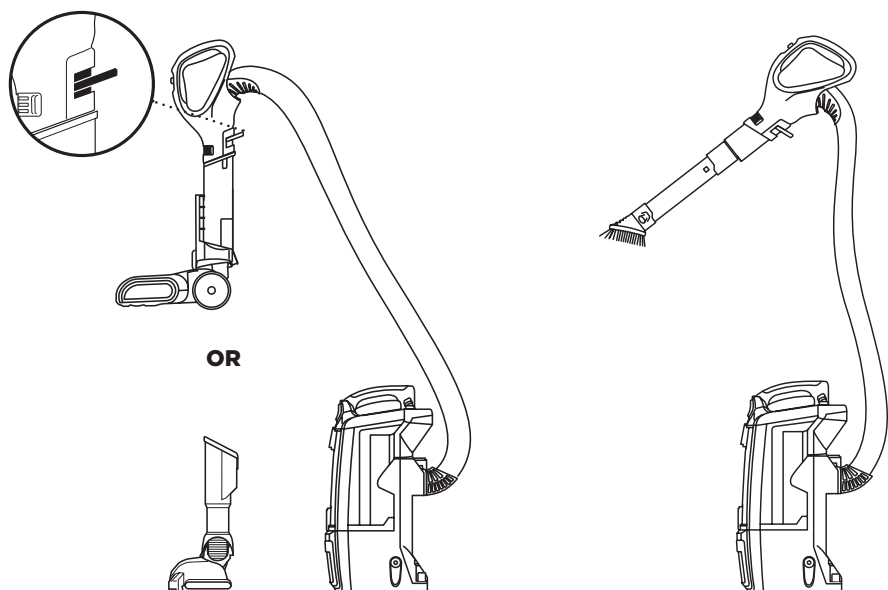

**2** Insert handle into either the motorized floor nozzle or the Dust-Away™ Pro. Now you have a convenient way to clean stairs.

### LIFT-AWAY CLEANING

**1** Attach desired accessory directly into handle. You can also attach the accessory to the wand for extended reach.

# COMPATIBLE ACCESSORIES

---

There are a variety of accessories that are compatible with this vacuum series.

The top flap of your box shows the select accessories that are included with your model.

**To purchase additional accessories, go to [sharkclean.com](http://sharkclean.com)**

## **A Home & Car Detail Tool**

Extension tubes and micro tools to clean the tightest spaces.

## **B Pet Power Brush**

Designed to remove pet hair and ground-in dirt from carpeted stairs and upholstery.

## **C Dust-Away™ & Microfiber Pad**

Durable enough for big crumbs and debris but gentle enough for delicate dusting on hardwood and tile floors.

## **D Duster Crevice**

Two cleaning tools in one—the crevice tool gives you extended cleaning reach for small spaces, while the dusting brush cleans a multitude of surfaces.

## **E Caddy**

Transforms your Rotator™ into a canister vacuum, giving you the freedom to roll the pod along while keeping cleaning tools close by.

## **F Pet Multi-Tool**

Two cleaning tools in one—the stiff bristle brush gets stuck-on debris off a multitude of surfaces. Remove the bristles to reveal an upholstery tool for removing stubborn pet hair from upholstery and more.

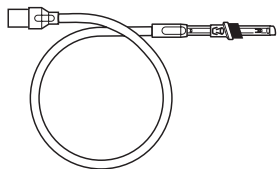
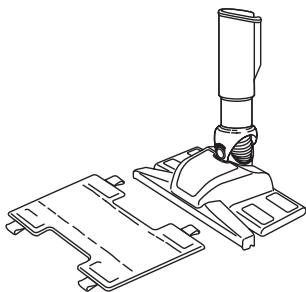
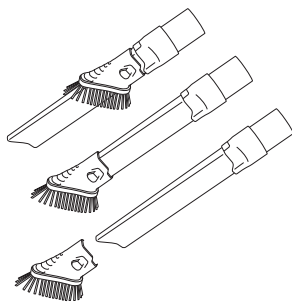
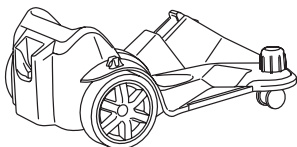
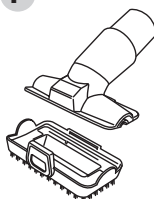
**A****B****C****D****E****F**

# MAINTENANCE

To keep your vacuum's suction power optimal, follow these instructions. Make sure unit is off and cord is unplugged.

.....

**⚠ WARNING:** To reduce the risk of shock and unintended operation, turn power off and unplug unit before servicing.

**⚠ Hand wash with water only to prevent damage from cleaning chemicals. Allow ALL filters to dry completely before replacing in the vacuum to prevent liquid from being drawn into electric parts.**

**★ IMPORTANT:** Do not use soap when cleaning the HEPA filter.

.....

## RECOMMENDED FILTER CLEANING SCHEDULE:

### Pre-Motor Filter Kit

(Foam & Felt)  
XFF680  
Clean every 3 months.

### Post-Motor Filter

(HEPA)  
XHF680  
Clean once a year.

## STEP 1

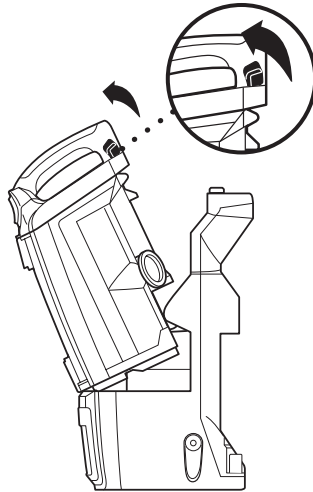

## STEP 2

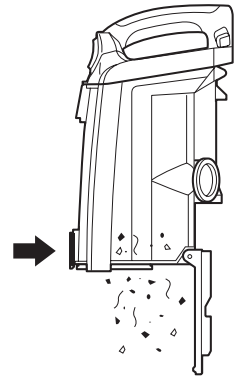

## EMPTYING THE DUST CUP

- 1** Pull up on dust cup release latch and lift dust cup off pod.
- 2** Hold dust cup over a trash bin and press the empty-release latch on the bottom.

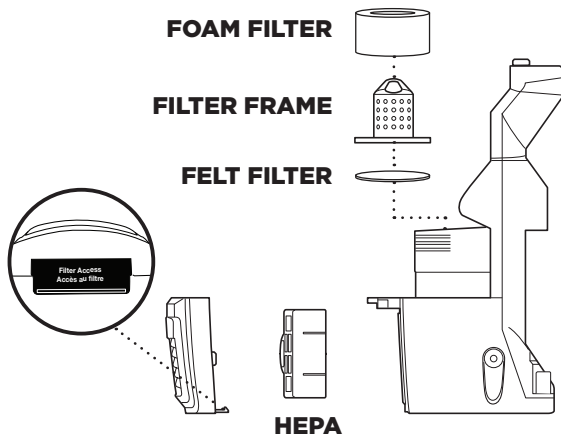
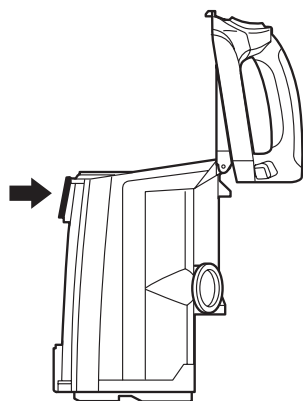
**STEP 3****CLEANING THE FILTERS**

**3** Press top dust cup release latch to access dust screen and remove built-up debris as required.

**1 Pre-Motor (foam and felt):**

With the dust cup removed, take out and rinse the foam and felt filters with water. Tap loose dirt off filters between washes as needed.

**2 Post-Motor (HEPA):**

To access the HEPA filter, reach under the grill and pull the Filter Access latch to remove the grill. Remove and rinse the HEPA filter.

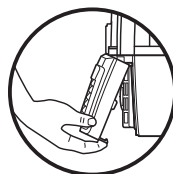

# MAINTENANCE

---

**⚠ WARNING:** To reduce the risk of shock and unintended operation, turn power off and unplug unit before servicing.

**💡 TIP:** You do not need any tools to open the floor nozzle—just a coin.

## STEP 1

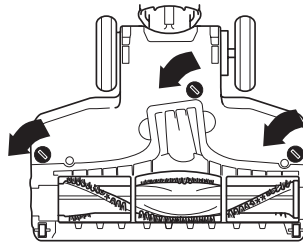

### CHECKING FOR BLOCKAGES & MAINTAINING BRUSHROLL

- 1 Use a coin to unlock the 3 locks on the bottom of the floor nozzle.

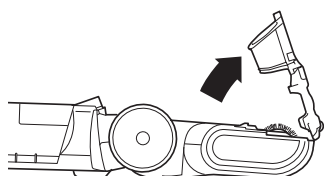
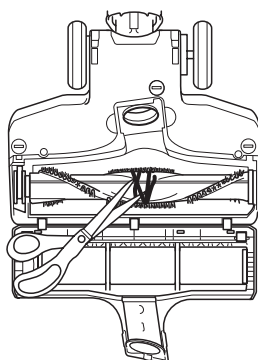
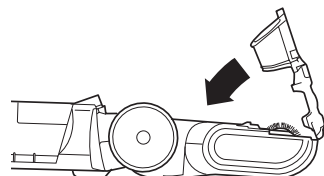
**STEP 2****STEP 3****STEP 4**

- 2** A portion of the base is hinged for better access to the brushroll and exposure to the airway. Shine a flashlight from the bottom of the base to check for blockages.
- 3** Remove any hair, fibers, or debris that is wrapped around the brushroll. There is a groove that allows a pair of scissors to cut across to loosen debris.
- 4** To reassemble, replace base by lining it up along the front of the nozzle. Rotate closed and lock the 3 locks.

# TROUBLESHOOTING GUIDE

---

**⚠ WARNING: To reduce the risk of shock and unintended operation, turn power off and unplug unit before servicing.**

## **Vacuum is not picking up debris. No suction or light suction.**

**(Refer to Maintenance section for more information.)**

- Check filters to see if they need cleaning. Follow instructions for rinsing and drying the filters before re-inserting in the vacuum.
- Dust cup may be full; empty dust cup.
- Check hose, hose connections, nozzles, and accessories for blockages; clear blockages if required.
- Remove any string, carpet fibers, or hair that may be wrapped around the brushroll.

## **Vacuum lifts area rugs.**

- Turn off unit to disengage the brushroll. Move switch to Hard Floor setting for suction-only cleaning, and turn unit back on.
- Suction is powerful. Take care when vacuuming area rugs or rugs with delicately sewn edges.
- To minimize suction, refer to Suction Control section for more information on how to use.

## **Brushroll does not spin.**

- If Brushroll Indicator Light on the floor nozzle turns red, the brushroll has stopped spinning. Immediately turn off and unplug vacuum, disconnect the nozzle, and remove blockage before reconnecting and turning vacuum back on.
- If brushroll indicator light repeatedly turns red on carpet, try moving suction release to minimum.
- With the power on, recline the handle, which will automatically turn on the brushroll.
- Make sure the carpet height selector is not set to Hard Floor.

## **Vacuum turns off on its own or indicator light flashes red.**

- This vacuum is equipped with a motor-protective thermostat. If your vacuum overheats, the thermostat will automatically turn the suction motor off. Perform the following steps to restart the thermostat:
  1. Turn vacuum off and unplug it.
  2. Empty dust cup and clean filters (see Maintenance section).
  3. Check for blockages in hose, accessories, and inlet openings.
  4. Allow unit to cool for a minimum of 45 minutes.
  5. Plug in vacuum and turn it on.
- If hose is not fully connected to the pod, it can cause a poor electrical connection and the hose can come loose, turning the vacuum off.
  1. Turn vacuum off and unplug it.
  2. Empty dust cup and clean filters.
  3. Check for blockages in hose, accessories, and inlet openings.
  4. Remove cord from cord hook so hose latch can be seen and engaged.
  5. Ensure you hear an audible click at all connection points:
    - a. Where hose meets back of pod (may require additional force; pull on hose to ensure latch is fully engaged)
    - b. Where wand plugs into floor nozzle
    - c. Where handle plugs into wand
  6. Plug in vacuum and turn it on.

Note: If vacuum still does not start, contact Customer Service at 1-800-798-7398.







# Shark NINJA SEVEN (7) YEAR LIMITED WARRANTY

The 7-Year Limited Warranty applies to purchases made from authorized retailers of **SharkNinja Operating LLC**. Warranty coverage applies to the original owner and to the original product only and is not transferable.

SharkNinja warrants that the unit shall be free from defects in material and workmanship for a period of 7 years from the date of purchase when it is used under normal household conditions and maintained according to the requirements outlined in this instruction manual, subject to the following conditions and exclusions.

## What is covered in my warranty?

1. The original unit and/or non-wearable components deemed defective, in SharkNinja's sole discretion, will be repaired or replaced for up to 7 years from the original purchase date.
2. In the rare event that a replacement unit is issued, the warranty coverage ends six months following the receipt date of the replacement unit or the remainder of the existing warranty, whichever is greater. If the unit is replaced, SharkNinja reserves the right to replace the unit with one of equal or greater value.

## What is not covered in my warranty?

Our Customer Care/Product Specialists are available to provide all the warranty service options available to you including the possibility of upgrading to our VIP Warranty Service Options for select product categories.

1. Normal wear and tear of wearable parts such as foam filters, HEPA filters, pads etc., which require regular maintenance and/or replacement to ensure the proper functioning of your unit are not covered by this warranty.
2. Any unit that has been tampered with or used for commercial purposes.
3. SharkNinja will cover the cost for the customer to send in the unit to us for repair or replacement. A fee of \$19.95 for return shipping costs will be charged at the time of return shipment of the repaired or replacement unit. Our Customer Care /Product Specialists are available to provide all the warranty service options available to you including upgrading to our VIP Warranty Service Options.
4. Damage caused by misuse, abuse, or negligent handling, or damage due to mishandling in transit.
5. Consequential and incidental damages.
6. Defects caused by or resulting from damages from shipping or repairs, service, or alteration to the product or any of its parts which have been performed by a repair person not authorized by SharkNinja.
7. Products purchased, used or operated outside of North America.

## Problems with your unit/How to get service

If your appliance fails to operate properly while in use under normal household conditions within the warranty period, visit [sharkclean.com](http://sharkclean.com) for product care/maintenance self-help. Our customer care and product specialists are also available at 1-800-798-7398 to assist with product support and warranty service options.

## How to initiate a warranty claim

You must first activate your warranty by registering your unit online at [sharkclean.com/customersupport](http://sharkclean.com/customersupport). (Note: Purchases made directly from SharkNinja are automatically registered with us and the warranty activated.) Alternatively you can call 1-800-798-7398 to have a customer care specialist assist you. Please note you must call 1-800-798-7398 to initiate a warranty claim. Return and Packing Instruction information will be provided at that time.

The customer care line is open Monday-Saturday, 7am-11pm ET and Sunday, 9am-8pm ET.

Replacement parts are available for purchase at [sharkclean.com](http://sharkclean.com). For more information on what is classified as wearable and non-wearable parts, please visit [sharkwarranty.com](http://sharkwarranty.com).

This warranty gives you specific legal rights, and you also may have other rights that vary from state to state.

Some states do not permit the exclusion or limitation of incidental or consequential damages, so the above may not apply to you.



**SharkNinja Operating LLC**  
**US: Newton, MA 02459**  
**CAN: Ville St-Laurent, QC H4S 1A7**  
**1-800-798-7398**  
**sharkclean.com**

Illustrations may differ from actual product. We are constantly striving to improve our products, therefore the specifications contained herein are subject to change without notice.

Shark is registered trademarks of SharkNinja Operating LLC.  
Dust-Away, Lift-Away and Rotator are trademarks of SharkNinja Operating LLC.

For SharkNinja U.S. Patent information visit  
[sharkninja.com/USPatents](http://sharkninja.com/USPatents)

© 2016 SharkNinja Operating LLC  
NV681\_40\_IB\_E\_160708\_6-800watt  
PRINTED IN CHINA



**@sharkcleaning**