

Shark[®]

Steam Pocket[®] Mop

S3501 Series

OWNER'S GUIDE



IMPORTANT SAFEGUARDS

PLEASE READ CAREFULLY BEFORE USE • FOR HOUSEHOLD USE ONLY

If the plug does not fit fully into the outlet, reverse the plug. If it still does not fit, contact a qualified electrician. **DO NOT** force into outlet or try to modify to fit.

WARNING

To reduce the risk of fire, electric shock, injury, or property damage:

WHEN USING YOUR SHARK® STEAM POCKET® MOP, BASIC SAFETY PRECAUTIONS SHOULD ALWAYS BE FOLLOWED, INCLUDING THE FOLLOWING:

READ ALL INSTRUCTIONS BEFORE USING YOUR STEAM MOP.

 **WARNING:**

DANGER OF SCALDING.

The steam emitted from the Steam Mop is very hot and may cause scalding. Please use caution when using the Steam Mop.

 **WARNING: KEEP Steam Mop AWAY FROM CHILDREN.**

POLARIZED PLUG:

This Steam Mop has a polarized plug (one blade is wider than the other). As a safety feature, this plug will fit into a polarized outlet only one way. If the plug does not fit fully into the outlet, reverse the plug. If it still does not fit, contact a qualified electrician. Do not attempt to defeat this safety feature. It is not recommended to use an extension cord with this product.

1. When in use, **NEVER** turn the Steam Mop over on its side or direct steam toward people, pets, or plants.
2. Use the system only for its intended use.
3. **DO NOT** use for space-heating purposes.
4. **DO NOT** use outdoors.
5. **DO NOT** leave the Steam Mop unattended when plugged in. **ALWAYS** unplug the power cord from the electrical outlet when not in use and before servicing.
6. **DO NOT** allow the Steam Mop to be used by children. Close attention is necessary when used near children, pets, or plants.
7. Use only as described in this owner's guide.
8. Use only manufacturer's recommended accessories.
9. **DO NOT** use with damaged cord or plug. If Steam Mop is not working as it should or has been dropped, damaged, left outdoors, or dropped into water, return it to SharkNinja Operating LLC for examination and repair. Incorrect reassembly or repair can cause a risk of electrical shock or injury.
10. To protect against a risk of electric shock, **DO NOT** immerse the Steam Mop in water or any other liquids.
11. **DO NOT** handle the plug or Steam Mop with wet hands or operate it without wearing shoes.

12. **DO NOT** pull or carry by cord, use cord as a handle, close a door on cord, or pull cord around sharp edges or corners. **DO NOT** run Steam Mop over cord. Keep cord away from heated surfaces.
13. **DO NOT** unplug by pulling on power cord. To unplug, grasp the plug not the power cord. **DO NOT** use extension cords or outlets with inadequate current-carrying capacity.
14. **DO NOT** put any objects into the steam nozzle openings. Discontinue use if the steam nozzle is blocked.
15. **DO NOT** put hands or feet under the Steam Mop. It gets very hot.
16. Use **ONLY** on flat, horizontal surfaces. **DO NOT** use on walls, counters, or windows.
17. **DO NOT** use on leather, wax-polished furniture, synthetic fabrics, velvet, or other delicate, steam-sensitive materials.
18. **DO NOT** add cleaning solutions, scented perfumes, oils, or any other chemicals to the water used in the Steam Mop as this may damage it or make it unsafe for use. If you live in a hard-water area, we recommend using distilled water in your Steam Mop.
19. **NEVER** leave any Dirt Grip™ pad in one spot while using or storing for an extended period of time, as this may damage your surfaces.
20. You can release the Dirt Grip pad after you have unplugged the Steam Mop and allowed it to cool.
21. When cleaning the exterior of the Steam Mop, unplug the power cord from the electrical outlet and clean the Steam Mop with a dry or damp cloth. **DO NOT** pour water or use alcohol, benzene, or paint thinner on the Steam Mop.

22. Extreme caution should be exercised when using the Steam Mop to clean stairs.
23. **NEVER** use Steam Mop without the Dirt Grip pad attached.
24. Keep your work area well lit.
25. Store Steam Mop indoors in a cool, dry place.
26. To avoid circuit overload, **DO NOT** operate another appliance on the same socket (circuit) as the Steam Mop.
27. To avoid scalding injuries, **ALWAYS** unplug and allow the Steam Mop to cool before removing or changing mop heads, accessories, or Dirt Grip™ pads.

IMPORTANT: Your Steam Mop is designed to clean hard-floor surfaces that will withstand high heat. **DO NOT** use on unsealed wood or unglazed ceramic floors. On surfaces that have been treated with wax and on some unwaxed floors, the sheen may be removed by the heat and steam action. We recommend testing an isolated area of the surface to be cleaned before proceeding. We also recommend that you check the use and care instructions from the floor manufacturer.

SAVE THESE INSTRUCTIONS

GETTING STARTED

PARTS

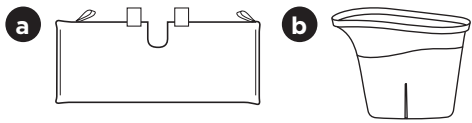

- a Pocket Pad
- b Filling Flask
- c Quick Release Cord Wrap
- d Cord Clips
- e Mop Handle
- f Telescopic Latch
- g Water Tank Window
- h Power Light
- i Water Tank Cap
- j Rectangle Mop Head

Not all accessories come with all units. For a list of the accessories included with this model, see the top inside flap of the box. To order additional accessories, visit sharkaccessories.com.

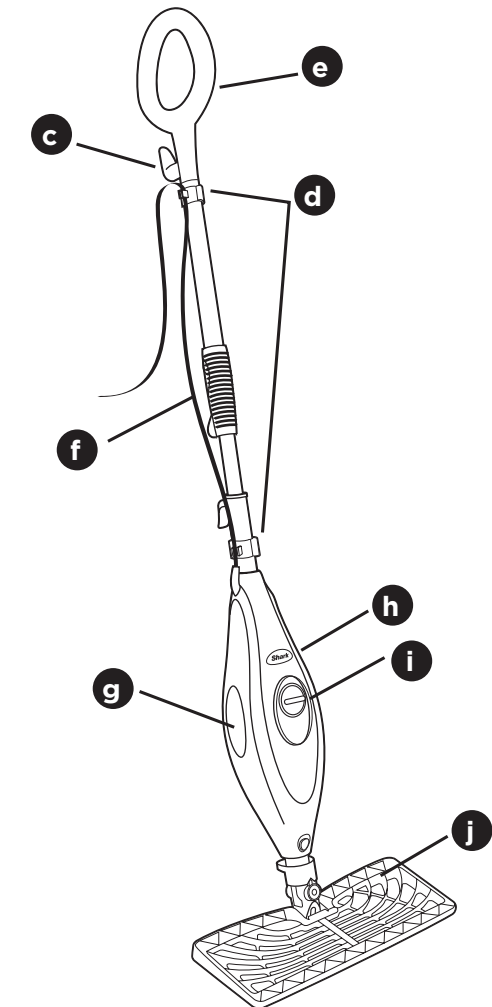

USING YOUR SHARK® STEAM POCKET® MOP

ASSEMBLY

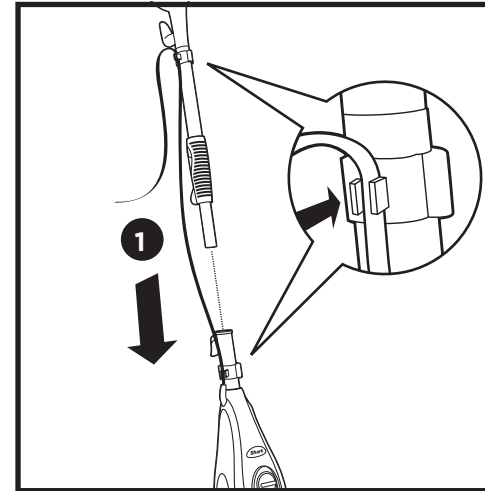

- 1** Insert the mop handle into the tube on the top of the mop body, pressing until it clicks into place.

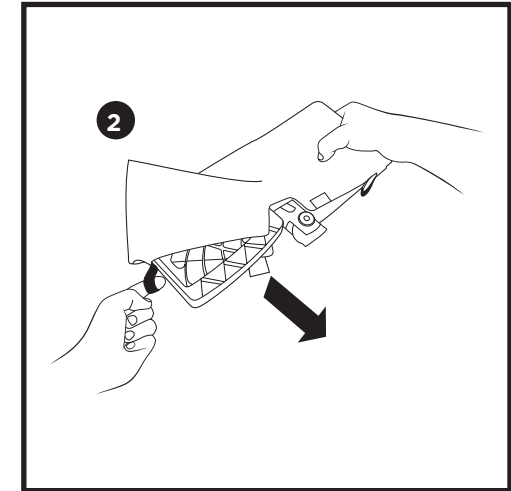

- 2** Select a cleaning pad. Fit one side of the pocket onto the mop head first, then using the lavender loop, pull the pocket over the head. Attach the quick fasteners on the top of the pocket to secure in place.

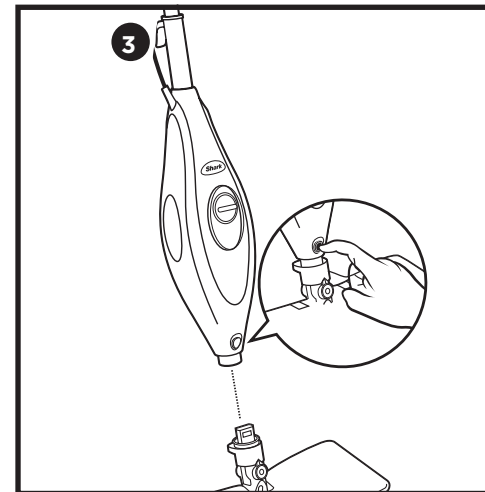

- 3** Snap the mop head into the bottom of the mop body, pressing until it clicks into place. To remove the mop head, press the release button near the bottom of the mop body.

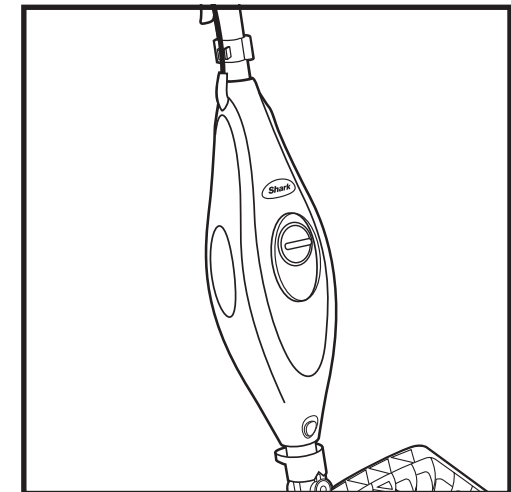

NOTE: When assembling your Shark Steam Pocket® Mop there may be a little water in or around the water tank. This is because we test all our mops before you buy them, so you get a quality Shark Steam Pocket Mop.

ASSEMBLY CONT.

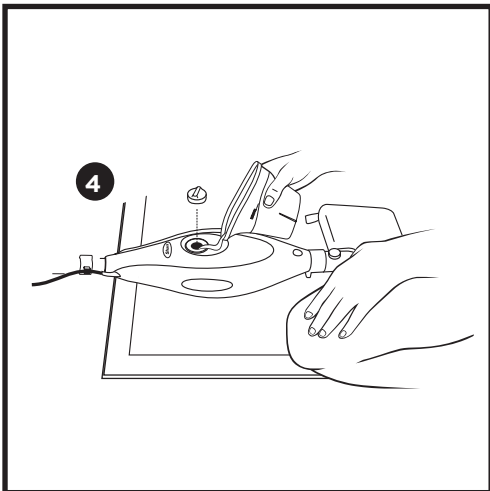

4 Place the mop on a stable, level surface. Turn the water tank cap counterclockwise to remove. Use the filling flask to add water to the tank, making sure to not exceed the max fill line. Replace the cap and turn it clockwise to tighten.

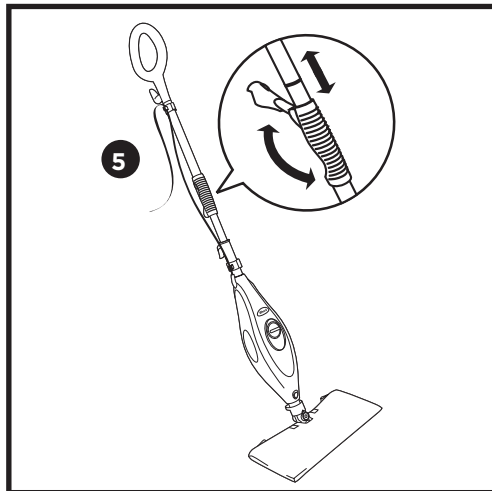

5 To adjust the length of the mop, lift the latch on the tube 90 degrees to the open position. Holding the handle, extend the tube to the height that's right for you and then close the latch to the locked position.

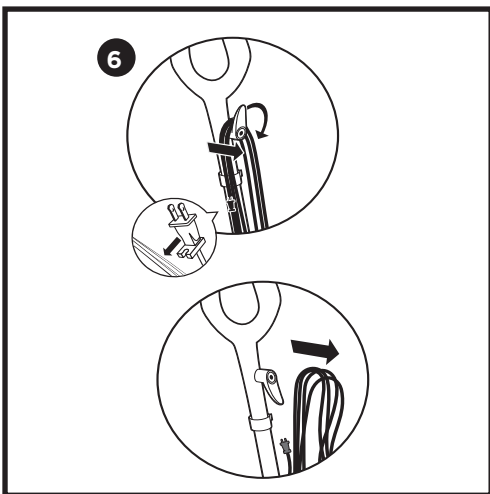

6 Pull and twist the quick release cord holder to unwrap the power cord completely.



7 Plug into an electrical outlet. The power light will illuminate. It takes approximately 30 seconds for the mop to heat up and the steam to be ready.

NOTE: Steam is created automatically with the mopping motion.

CLEANING OPERATION

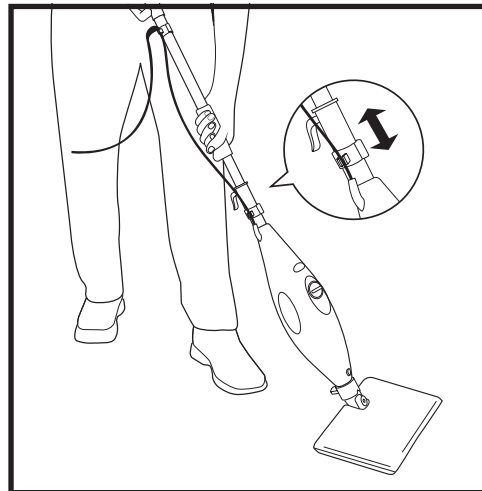

Pump the handle a few times in a downward motion. This pumping action will release steam as you mop and allows you to customize the amount of steam you use. Begin mopping with a forward and backward motion. The natural motion of mopping will produce steam.

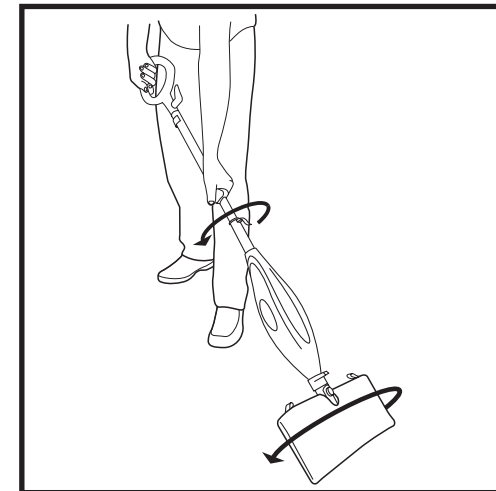

When one side of the pocket gets dirty, just turn the mop head over and clean with the other side of the pad.

When the water tank is empty, the Steam Pocket Mop will stop producing steam. You can refill the water tank at any time as long as the mop is unplugged from the outlet.

SANITIZING OPERATION

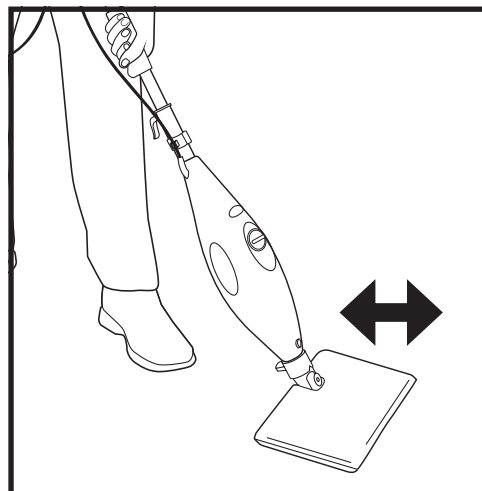

TO SANITIZE* WITH THE RECTANGLE MOP HEAD

- 1** Only sanitize sealed, hard-floor surfaces.
- 2** Plug in the Steam Mop, then wait 30 seconds for it to heat up.
- 3** To activate steam, pump the handle a few times.
- 4** Start mopping with a forward and backward motion. After 3 minutes, your Steam Mop will be ready to sanitize.
- 5** Mop the area to be sanitized, moving forward and backward at least 15 times."

*Sanitization studies were conducted under controlled test conditions using the rectangle mop head only. Household conditions and results may vary.

CARING FOR YOUR SHARK® STEAM POCKET® MOP

AFTER USE

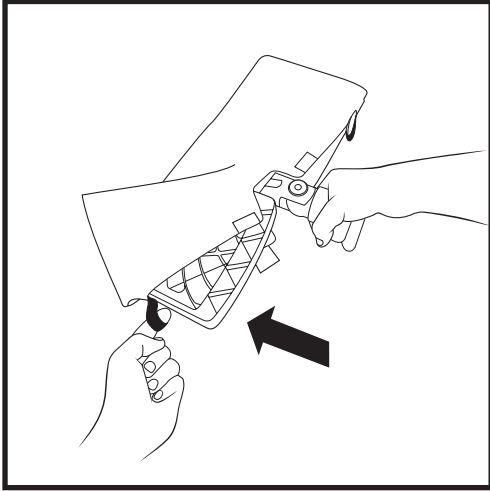

When you have finished using the Steam Pocket Mop, unplug the cord from the outlet and let the unit cool 2-3 minutes. Release steam by pumping the handle several times before removing the Pocket Pad from the mop head.

Remove the Pocket Pad by releasing the quick fasteners and using the lavender loop on the side to pull off the pad. Avoid contact with the hot pad. Make sure to empty the water tank before storing the Steam Mop.

NOTE: Please wait 2 to 3 minutes for the Steam Mop to cool off before removing the mop head or the Pocket Pad. **NEVER** leave the Steam Mop with a damp/wet Pocket Pad on any floor.

USING YOUR SHARK® STEAM POCKET® MOP

STORAGE

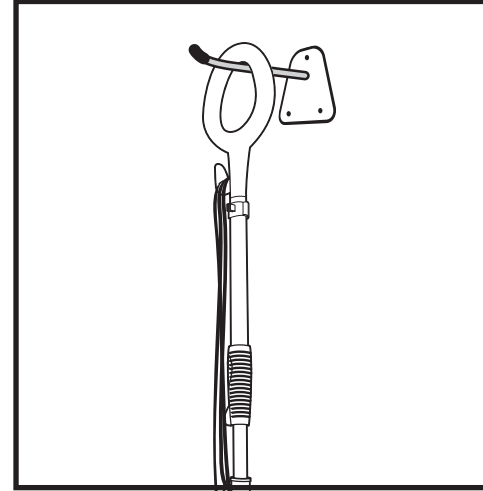

To store the steam mop, first release all steam, and allow the unit to cool completely. Hang the steam mop from a large hook (not included).

NOTE: To store the Steam Mop upright, lean it against a wall for added support and safety. **ALWAYS** store your Steam Pocket Mop with the Pocket Pad removed, away from children or high-traffic areas.

POCKET PAD CARE INSTRUCTIONS

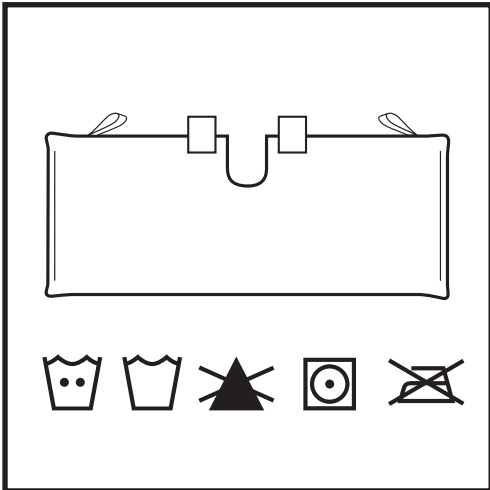

Machine wash the Pocket Pads separately with warm water using liquid detergent. Before washing Pocket Pads, close the hook-and-loop fasteners so they won't snag. **NEVER USE BLEACH, POWDERED DETERGENT, OR FABRIC SOFTENERS** as they may damage or leave a coating on the Pocket Pads that will reduce their cleaning performance and absorbency. Pocket Pads

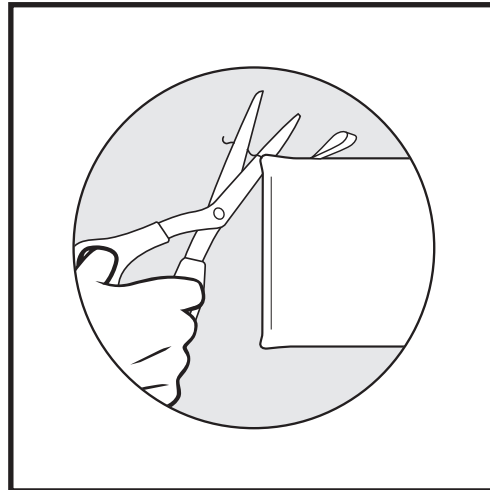

should be line-dried or tumble-dried on a low setting, as this will extend the life of the microfiber fabric.

Loose fibers can indicate wearing of the microfiber fabric. **DO NOT** pull the loose fibers as this can cause the weave to come undone. Simply trim the loose fibers with scissors.

PARTS AND ACCESSORIES

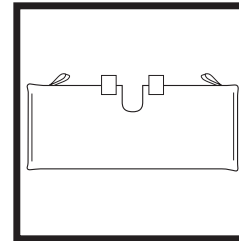

Rectangle Scrub Pocket Pad
P139W

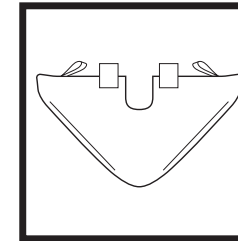

Triangle Scrub Pocket Pad
P179W

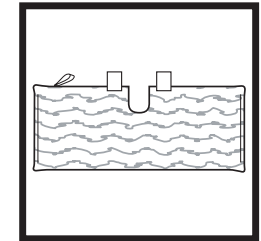

Dirt Grip™ Pocket Pad
P186W

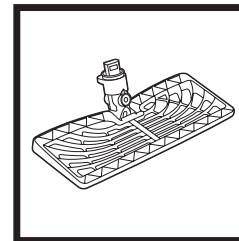

Rectangle Mop Head
1024SO

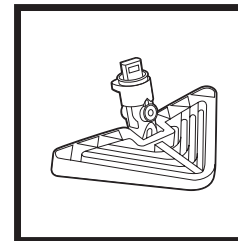

Triangle Mop Head
1025SO

ORDERING REPLACEMENT PARTS

To order additional parts and accessories, visit sharkaccessories.com or call 1-800-798-7398.

TROUBLESHOOTING

PROBLEM	POSSIBLE REASONS & SOLUTIONS
The Steam Pocket Mop will not turn on.	Your Steam Pocket Mop should be securely plugged into an electrical outlet. Check your fuse or breaker. If your unit still doesn't work, please call our customer service at 1-800-798-7398.
Steam Pocket Mop will not make steam.	Prime the pump. See Cleaning Operation section for more information. Is there water in the water tank? If not, add water to your Steam Pocket Mop following the instructions.
Steam Pocket Mop leaves water on the floor.	Check to see if your Pocket Pad is too wet. Unplug the steam mop, let it cool, and then change the Pocket Pad. Make sure the Pocket Pad is attached correctly.
Steam Pocket Mop is hard to push.	Make sure the Pocket Pad is attached correctly. Try increasing the height of the pole for better leverage. The Steam Mop might be hard to push/pull if the Pocket Pad isn't wet enough. It should get easier to push/pull the Steam Mop after it's been running for a few minutes. An overly dirty Pocket Pad could also result in the mop being harder to push. Flip the pad over or use a clean pad.

Shark NINJA

ONE (1) YEAR LIMITED WARRANTY

The One (1) Year Limited Warranty applies to purchases made from authorized retailers of **SharkNinja Operating LLC**. Warranty coverage applies to the original owner and to the original product only and is not transferable.

SharkNinja warrants that the unit shall be free from defects in material and workmanship for a period of one (1) year from the date of purchase when it is used under normal household conditions and maintained according to the requirements outlined in the Owner's Guide, subject to the following conditions and exclusions:

What is covered by this warranty?

- The original unit and/or non-wearable components deemed defective, in SharkNinja's sole discretion, will be repaired or replaced up to one (1) year from the original purchase date.
- In the event a replacement unit is issued, the warranty coverage ends six (6) months following the receipt date of the replacement unit or the remainder of the existing warranty, whichever is later. SharkNinja reserves the right to replace the unit with one of equal or greater value.

What is not covered by this warranty?

- Normal wear and tear of wearable parts, which require regular maintenance and/or replacement to ensure the proper functioning of your unit, are not covered by this warranty. Replacement parts are available for purchase at sharkaccessories.com.
- Any unit that has been tampered with or used for commercial purposes.
- Damage caused by misuse, abuse, negligent handling, failure to perform required maintenance, or damage due to mishandling in transit.
- Consequential and incidental damages.
- Defects caused by repair persons not authorized by SharkNinja. These defects include damages caused in the process of shipping, altering, or repairing the SharkNinja product (or any of its parts) when the repair is performed by a repair person not authorized by SharkNinja.
- Products purchased, used, or operated outside North America.

How to get service

If your appliance fails to operate properly while in use under normal household conditions within the warranty period, visit sharkclean.com/support for product care and maintenance self-help. Our Customer Service Specialists are also available at **1-888-228-5531** to assist with product support and warranty service options, including the possibility of upgrading to our VIP warranty service options for select product categories. Please register your product and have it with you when contacting Customer Service.

SharkNinja will cover the cost for the customer to send in the unit to us for repair or replacement. A fee of \$25.95 (subject to change) will be charged when SharkNinja ships the repaired or replacement unit.

How to initiate a warranty claim

You must call **1-888-228-5531** to initiate a warranty claim. You will need the receipt as proof of purchase. A Customer Service Specialist will provide you with return and packing instruction information.

How state law applies

This warranty gives you specific legal rights, and you also may have other rights that vary from state to state. Some states do not permit the exclusion or limitation of incidental or consequential damages, so the above may not apply to you.

REGISTER YOUR PURCHASE

 registryyourshark.com



RECORD THIS INFORMATION

Model Number: _____

Date Code: _____

Date of Purchase: _____
(Keep receipt)

Store of Purchase: _____

PLEASE READ CAREFULLY AND KEEP FOR FUTURE REFERENCE.

This Owner's Guide is designed to help you keep your Steam Mop running at peak performance.

SharkNinja Operating LLC

US: Needham, MA 02494

CAN: Ville St-Laurent, QC H4S 1A7

1-888-228-5531

sharkclean.com

Illustrations may differ from actual product. We are constantly striving to improve our products; therefore the specifications contained herein are subject to change without notice.

This product may be covered by one or more U.S. patents. See sharkninja.com/patents for more information.

