

Shark[®]

Rotator[®] Powered Lift-Away[®] Speed Upright Vacuum with Self-Cleaning Brushroll

ZU620 Series

OWNER'S GUIDE



IMPORTANT SAFETY INSTRUCTIONS

FOR HOUSEHOLD USE ONLY • PLEASE READ CAREFULLY BEFORE USE

If the plug does not fit fully into the outlet, reverse the plug. If it still does not fit, contact a qualified electrician. **DO NOT** force into outlet or try to modify to fit.

⚠ WARNING

To reduce the risk of fire, electric shock, injury, or property damage:

GENERAL WARNINGS

When using an electrical appliance, basic precautions should always be followed, including the following:

1. Your vacuum cleaner may consist of a motorized nozzle, wand, hose, and/or vacuum pod. This device contains electrical connections, electrical wiring, and moving parts that potentially present risk to the user.
2. Use only identical replacement parts.
3. Carefully observe and follow the instructions provided below to avoid improper use of the appliance. **DO NOT** use the vacuum for any purpose other than those described in this manual.
4. Before use, carefully inspect all parts for any damage. **DO NOT** use if any parts are damaged.
5. The use of an extension cord is **NOT** recommended.
6. This vacuum cleaner contains no serviceable parts.

USE WARNINGS

7. This appliance can be used by persons with reduced physical, sensory or mental capabilities or lack of experience and knowledge if they have been given supervision or instruction concerning use of the appliance in a safe way and understand the hazards involved. Cleaning and user maintenance shall not be made by children.
 - a) Keep the appliance and its cord out of reach of children. **DO NOT** allow the appliance to be used by children. **DO NOT** allow to be used as a toy. Close supervision is necessary when used near children.

8. Always turn off the vacuum cleaner before connecting or disconnecting any motorized nozzles or other accessories.
9. **DO NOT** handle plug or vacuum cleaner with wet hands.
10. **DO NOT** use without filters in place.
11. Only use Shark® branded filters and accessories. Failure to do so will also void the warranty.
12. **DO NOT** damage the power cord:
 - a) **DO NOT** pull or carry vacuum cleaner by the cord or use the cord as a handle.
 - b) **DO NOT** unplug by pulling on cord. Grasp the plug, not the cord.
 - c) **DO NOT** run the vacuum cleaner over the power cord, close a door on the cord, pull the cord around sharp corners, or leave the cord near heated surfaces.
13. **DO NOT** put any objects into nozzle or accessory openings. **DO NOT** use with any opening blocked; keep free of dust, lint, hair, and anything that may reduce airflow.
14. **DO NOT** use if nozzle or accessory airflow is restricted. If the air paths or the motorized floor nozzle become blocked, turn the vacuum cleaner off and unplug from electrical outlet. Remove all obstructions before you plug in and turn on the unit again.
15. Keep nozzle and all vacuum openings away from hair, face, fingers, uncovered feet, or loose clothing.

16. **DO NOT** use if vacuum cleaner is not working as it should, or has been dropped, damaged, left outdoors, or dropped into water.
17. Use extra care when cleaning on stairs.
18. **DO NOT** leave the vacuum cleaner unattended while plugged in.
19. When powered on, keep the vacuum cleaner moving over the carpet surface at all times to avoid damaging the carpet fibers.
20. **DO NOT** place vacuum cleaner on unstable surfaces such as chairs or tables.
21. Your Shark® vacuum may not be designed to stand up on its own. When taking a break from cleaning, you may need to lean it against furniture or a wall, or lay it flat on the floor. Using the vacuum for an application where the unit lacks stability may result in personal injury.
22. **DO NOT** use to pick up:
 - a) Liquids
 - b) Large objects
 - c) Hard or sharp objects (glass, nails, screws, or coins)
 - d) Large quantities of dust (drywall dust, fireplace ash, or embers). **DO NOT** use as an attachment to power tools for dust collection.
 - e) Smoking or burning objects (hot coals, cigarette butts, or matches)

- f) Flammable or combustible materials (lighter fluid, gasoline, or kerosene)
- g) Toxic materials (chlorine bleach, ammonia, or drain cleaner)

23. **DO NOT** use in the following areas:

- a) Poorly lit areas
- b) Wet or damp surfaces
- c) Outdoor areas
- d) Spaces that are enclosed and may contain explosive or toxic fumes or vapors (lighter fluid, gasoline, kerosene, paint, paint thinners, mothproofing substances, or flammable dust)

24. Turn off all controls before plugging in or unplugging the vacuum.
25. Unplug from electrical outlet when not in use and before any maintenance or cleaning.
26. Hand wash with water only. Washing with cleaning chemicals could damage the unit.
27. During cleaning or routine maintenance, **DO NOT** cut anything other than hair, fibers, or string wrapped around the brushroll.
28. Allow all filters to air-dry completely before replacing in the vacuum to prevent liquid from being drawn into electric parts.
29. Make sure the dust cup and all filters are in place after routine maintenance.
30. If provided, secure the power cord around the two cord hooks during storage.

To reduce the risk of electric shock, this appliance has a polarized plug (one blade is wider than the other). This plug will fit in a polarized outlet only one way. If the plug does not fit fully in the outlet, reverse the plug. If it still does not fit, contact a qualified electrician to install the proper outlet. Do not change the plug in any way.

SAVE THESE INSTRUCTIONS

ASSEMBLY

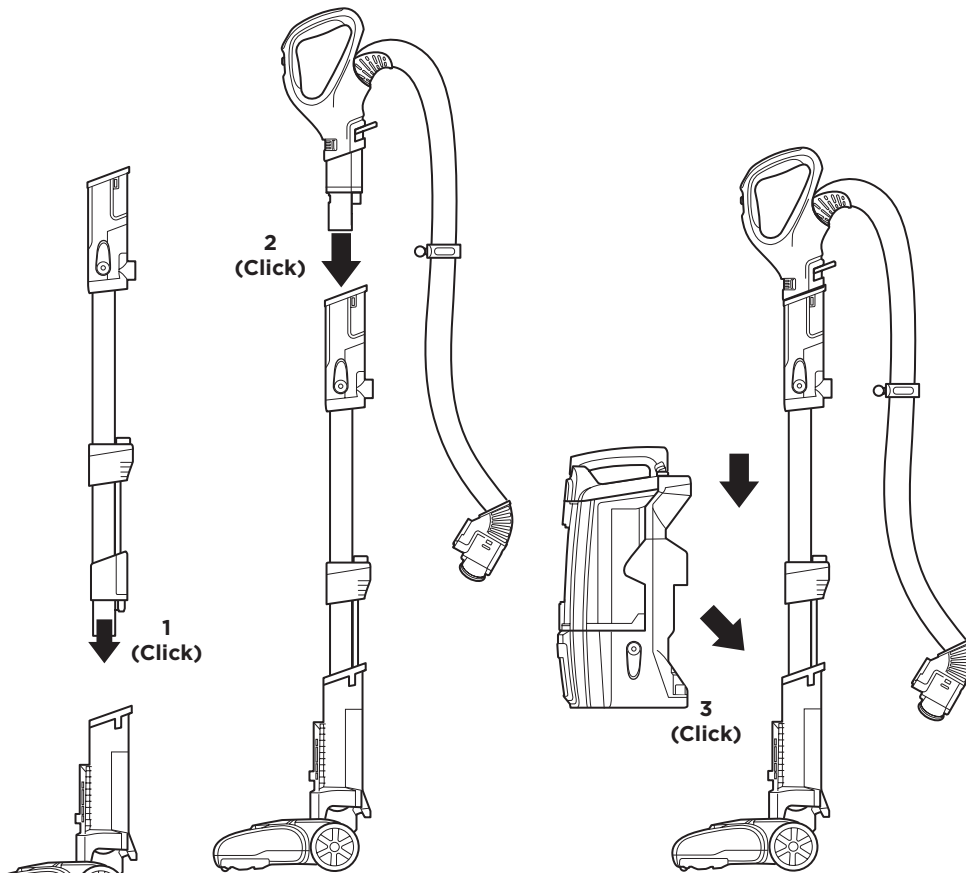

1. Insert **Wand** into **Floor Nozzle**.
2. Insert **Handle** into wand.
3. Place **Pod** onto wand and slide down to connect.
4. Connect **Hose** into back of pod, until it clicks into place.
5. Attach **Hose Clip** to wand.

For proper operation, ensure all parts are firmly clicked into place.

ASSEMBLY

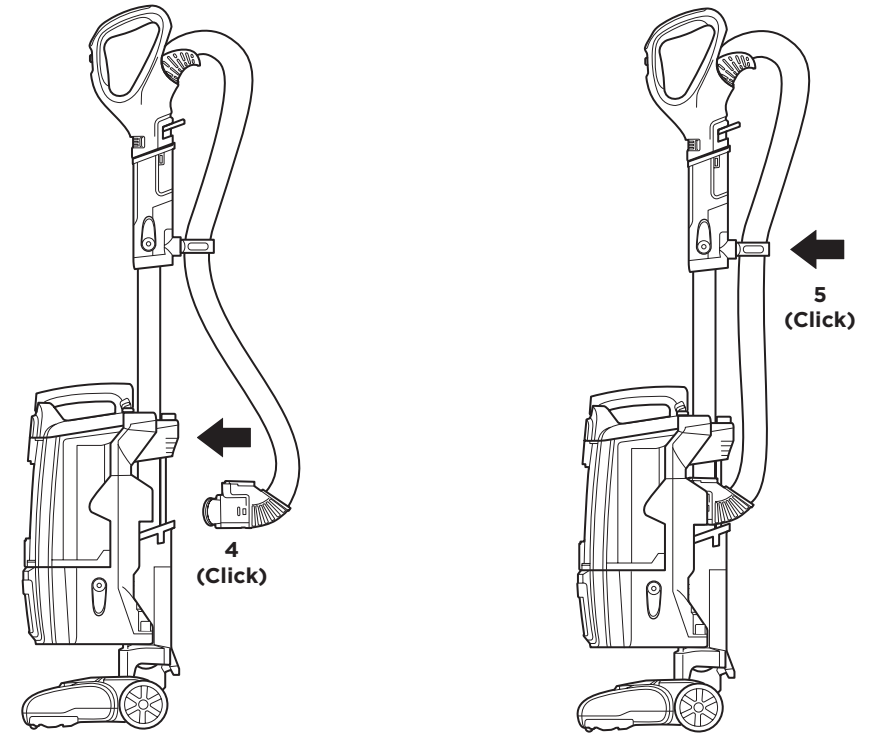

SETTINGS

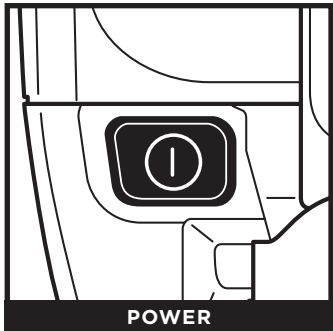

POWER

Press power button to turn the vacuum on or off. Please note the **Brushrolls** will not spin unless the wand is reclined.

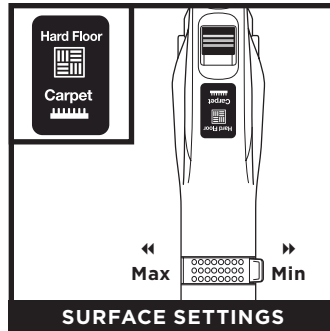

SURFACE SETTINGS

Slide the selector switch to the appropriate surface setting:

Thick Carpet & Area Rug Cleaning: Set Floor Selector to **Carpet** and slide Suction Control toward **Min** to reduce suction.

Carpet & Low Pile Cleaning: Set Floor Selector to **Carpet** and slide Suction Control toward **Max** to increase suction.

Hard Floor Cleaning: Set Floor Selector to **Hard Floor** and slide Suction Control toward **Max** to increase suction.

BRUSHROLL INDICATOR LIGHT

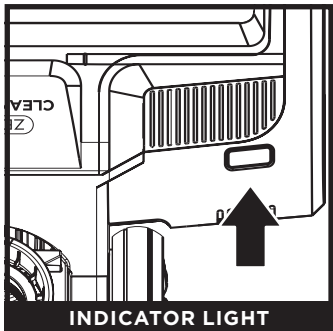

INDICATOR LIGHT

WHAT DOES THE BRUSHROLL INDICATOR LIGHT MEAN?

Solid Green: The brushrolls are spinning and working as they should.

Solid Red: There is a jam in the brushroll area. Turn your vacuum off and remove any blockages in the nozzle.

Flashing Red*: The motorized floor nozzle is overheating. Turn your vacuum off and wait a minimum of 45 minutes for it to cool down.

*See Troubleshooting section for further instructions.

NOTE: For deep cleaning per ASTM F 608 (embedded dirt in carpets) please use Carpet setting with Suction Control set at Max.

CLEANING MODES

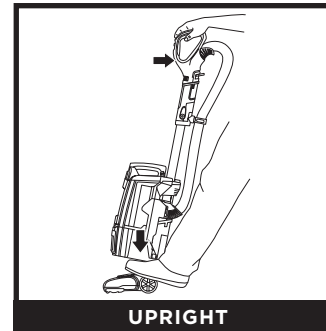

UPRIGHT

To engage brushrolls, turn on power, then place foot on floor nozzle and tilt handle back.

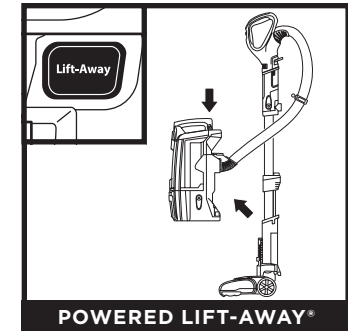

POWERED LIFT-AWAY®

Press the **Lift-Away** button to detach the pod from the floor nozzle.

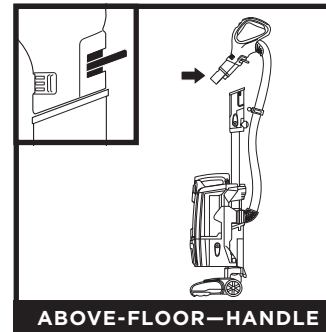

ABOVE-FLOOR—HANDLE

Press the **Handle** button to detach the handle from the wand.

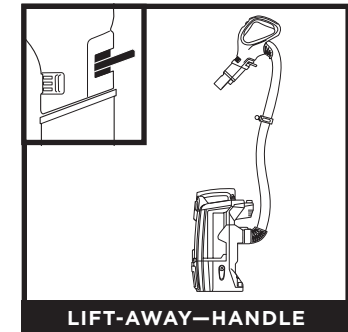

LIFT-AWAY—HANDLE

With pod removed, press the Handle button to detach the handle from the wand.

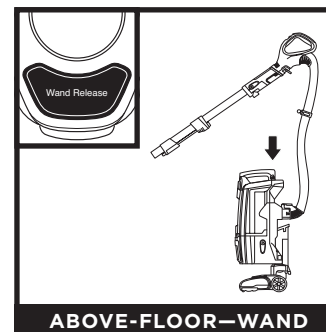

ABOVE-FLOOR—WAND

Press the **Wand Release** button to detach the wand from the pod.

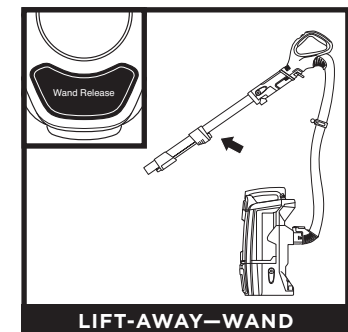

LIFT-AWAY—WAND

With pod removed, press the Wand Release button to detach the wand from the floor nozzle.

NOTE: All accessories are compatible with both the wand and the handle.

EMPTYING THE DUST CUP

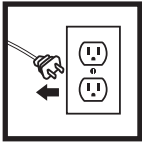

IMPORTANT: Unplug the power cord before performing any maintenance.

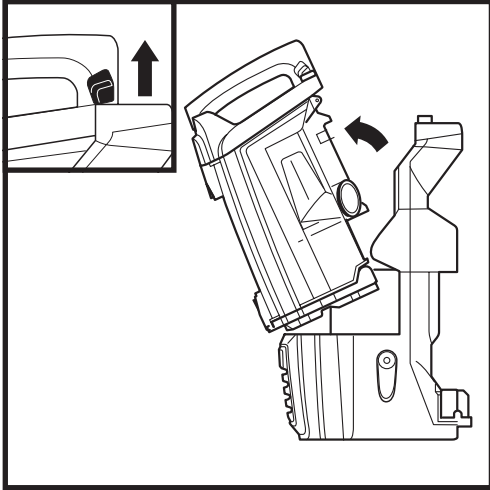

Pull up on **Dust Cup Release Latch** on the handle and lift dust cup off pod.

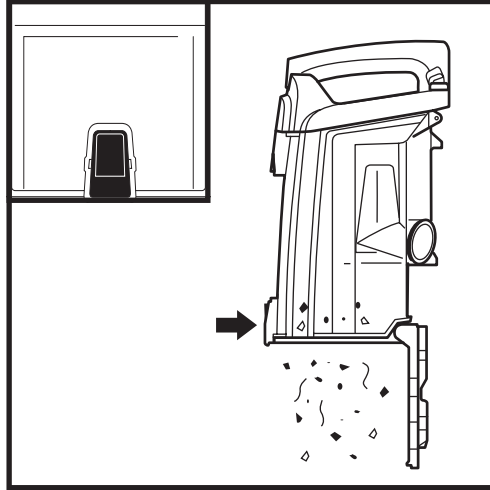

Hold dust cup over a trash bin and press the empty-release latch on the bottom to empty dust and debris into trash.

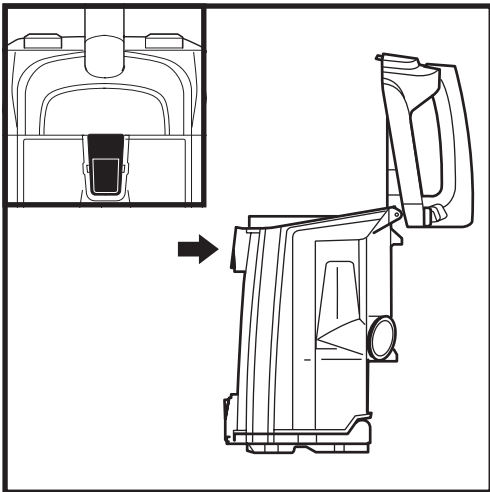

Press **Top Empty Release Latch** to access dust screen and remove built-up debris as necessary.

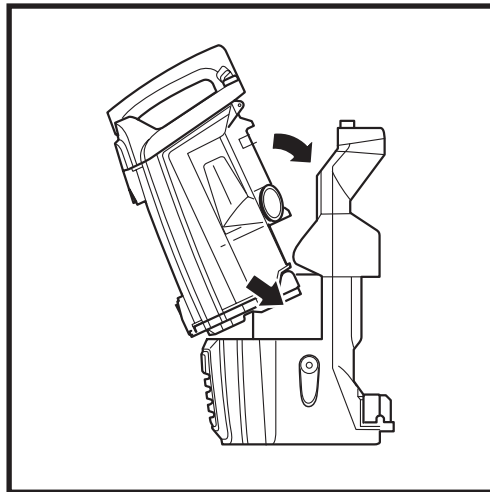

To reinstall, place bottom of dust cup into pod and then tilt until it clicks into place.

CLEANING AND REPLACING THE FILTERS

CLEANING FILTERS

Regularly clean and replace the filters to keep your vacuum's suction power optimal.

To clean filters, rinse with cold water **ONLY** to prevent damage from cleaning chemicals. Allow all filters to air-dry for at least 24 hours before reinstalling them to prevent liquid from being drawn into electric parts.

IMPORTANT: DO NOT use soap when cleaning the filters.

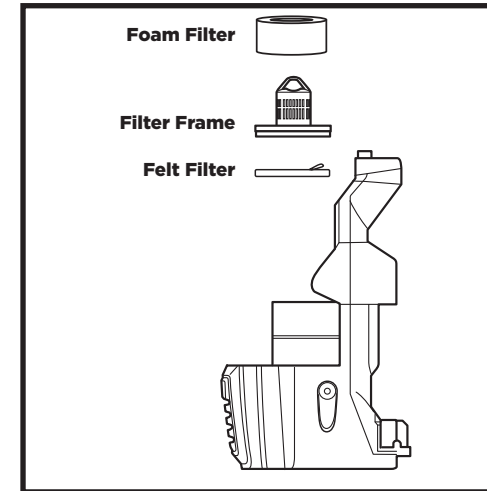

Pre-Motor (foam and felt):

With the dust cup removed, take out the foam and felt filters and rinse them with water only. Allow filter to air-dry completely before reinstalling. Tap loose dirt off filters between washes as needed.

CLEAN PRE-MOTOR FILTERS EVERY 3 MONTHS.

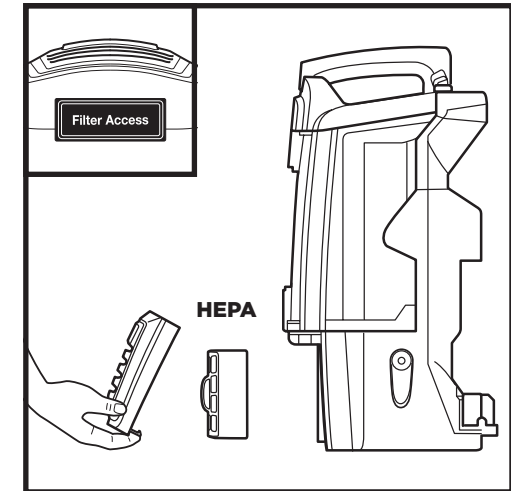

Post-Motor (HEPA):

To access the **HEPA Filter**, pull the latch under the filter cover and take off the cover. Remove the HEPA filter and rinse it with water only. Allow filter to air-dry completely before reinstalling.

CLEAN HEPA FILTER EVERY YEAR.

REPLACING FILTERS

The pre-motor filters should be replaced every 2.5 years. The post-motor HEPA filter should be replaced every 3 years.

Replacement Pre-Motor Foam & Felt Filter Kit
XFFK620

Replacement HEPA Filter
XHF620

NOTE: To order replacement parts and filters, visit sharkaccessories.com.

SELF-CLEANING BRUSHROLL

The self-cleaning brushroll automatically removes hair wrap. If some hair or debris remains after continued use, remove the cover on the bottom of the floor nozzle to access the brushroll.

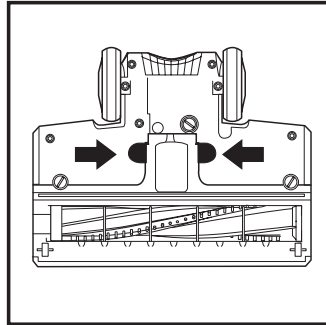
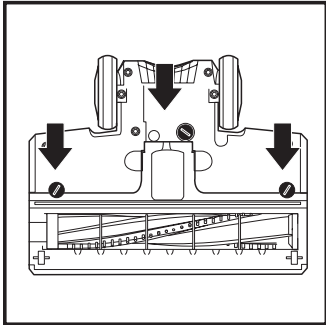

Using a coin, turn locks counterclockwise, then open the cover to access **Brushroll**.

NOTE: Cover will open but is not completely removable.

DEBRIS WRAPPED AROUND BRUSHROLL

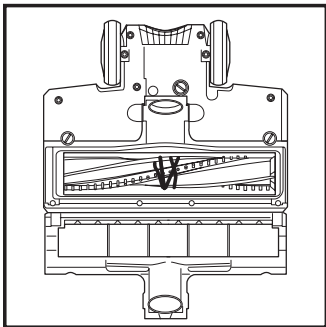

Clean off any debris on the bristles.

NOTE: If any hair is wrapped around the brushroll, extending cleaning time will allow the self-cleaning brushroll to remove it for you. If some fibers remain wrapped around brushroll after continued use, carefully cut debris with scissors and remove from brushroll.

DEBRIS BEHIND BRUSHROLL

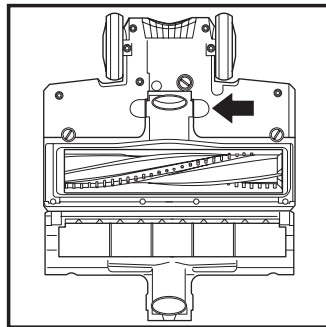

If you vacuum up a **hard or sharp** object or notice a noise change while vacuuming, check for blockages or objects caught in the brushroll.

Clear away any dust, dirt, or blockages in **Debris Intake**.

To close the cover, push down until it clicks into place, then close the locks with a coin.

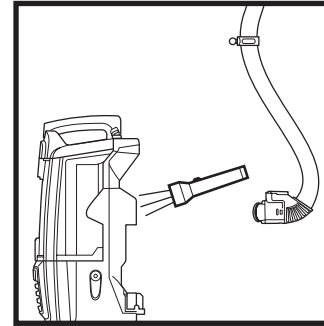

Detach hose from vacuum pod, and check hose and opening on back of pod for blockages.

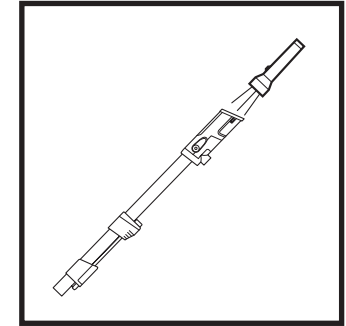

Detach wand from floor nozzle and handle, and check both ends for blockages.

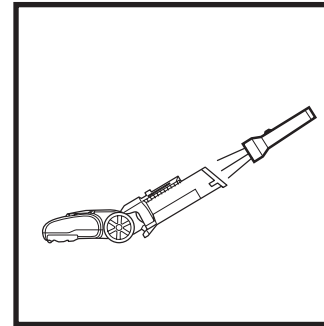

Detach wand from floor nozzle, tilt nozzle neck back, and check opening for blockages.

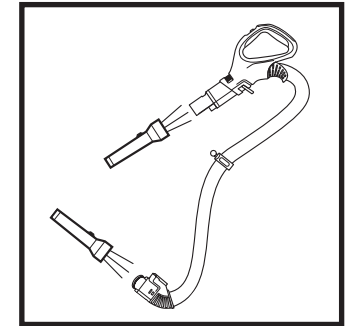

Detach handle from wand and hose from the vacuum pod, and check openings for blockages.

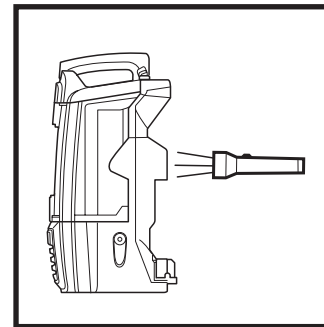

Detach dust cup from vacuum pod. Empty dust cup, remove debris from lint screen, and check for blockages.

AVAILABLE ACCESSORIES

A 8" Crevice Tool

This slim tool is great for cleaning in tight spaces, between couch cushions, and in hard-to-reach areas.

B Upholstery Tool

Perfect for large-particle pickup, dusting, and removing stubborn pet hair and lint from furniture and other upholstered surfaces.

C Dusting Brush

This brush dusts and cleans delicate surfaces. Great for use on fans, blinds, lampshades, and keyboards.

D Duster Crevice Tool

Two cleaning tools in one: the crevice tool gives you extended reach to clean in tight spaces, while the soft brush is ideal for dusting delicate surfaces.

E Pet Multi-Tool

A single convertible tool for cleaning tough pet messes two ways: use the stiff bristle brush to clean stuck-on debris, or take off the bristles to reveal an upholstery tool perfect for removing stubborn pet hair and large piles of debris.

F Self-Cleaning Pet Power Brush

Tackles pet hair and ground-in dirt from above-floor areas like carpeted stairs and upholstery, while actively removing hair wrap as it cleans.

G Dust-Away® Hard Floor Attachment

Durable enough for cleaning big crumbs and debris but gentle enough for delicate dusting on hardwood and tile floors.

H Canister Caddy

Transforms your Rotator® into a canister vacuum, giving you the freedom to roll the pod along while keeping cleaning tools close by.

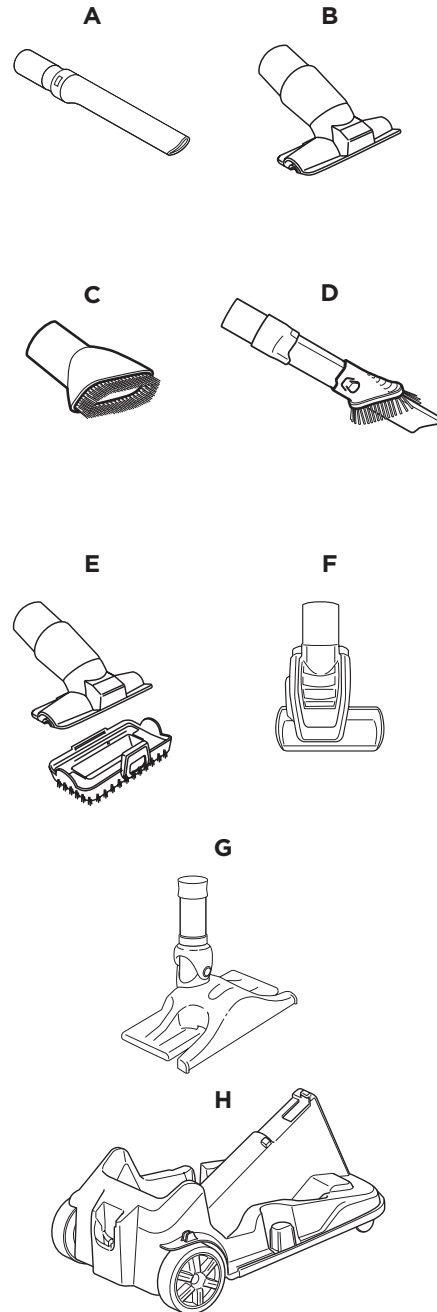

TROUBLESHOOTING

Vacuum is not picking up debris. No suction or light suction.

- Check filters to see if they need cleaning. Follow instructions for rinsing and air-drying the filters before reinserting in the vacuum.
- Dust cup may be full; empty dust cup.
- Check hose, hose connections, nozzle, wand, pod, and accessories for blockages. Clear any blockages found. Refer to Checking for Blockages section for more information.
- If any hair, string, or carpet fibers are wrapped around the brushroll, extend cleaning time to allow the self-cleaning brushroll to remove them.
 - If some hair or fibers remain wrapped around brushroll after continued use, remove the floor nozzle cover and carefully cut debris with scissors and remove from brushroll. Refer to Maintaining the Self-Cleaning Brushroll section for more information

Vacuum lifts area rugs.

- Make sure selector switch is set to Hard Floor.
- Suction is powerful. Take care when vacuuming area rugs or rugs with delicately sewn edges.
- To minimize suction, slide Suction Control to Min.

Brushroll does not spin.

- If the Brushroll Indicator Light turns red, immediately turn off and unplug the vacuum. Remove pod from floor nozzle. Clear any blockages or debris from the brushroll and nozzle. (See Checking for Blockages & Maintaining Brushroll.) Close the brushroll cover and reconnect the pod to the floor nozzle. Plug in the vacuum and turn on the power.
- With the power on, recline the handle, which will automatically turn on the brushroll.

Vacuum turns off on its own.

If your vacuum overheats, the thermostat will automatically turn the suction motor off. Perform the following steps to restart the thermostat:

1. Turn vacuum off and unplug it.
2. Empty dust cup and clean filters. Refer to the Emptying the Dust Cup and Cleaning and Replacing the Filters sections for more information.
3. Check for blockages in hose, accessories, and inlet openings.
4. Allow unit to cool for a minimum of 45 minutes.
5. Plug in the vacuum and turn on the power.

Indicator light flashes red.

1. Turn vacuum off and unplug it.
2. Detach the nozzle from the wand and pod.
3. Access the brushroll by using a coin to open the three locks on the bottom of the nozzle.
4. Clear any blockages or debris from the brushroll and floor nozzle.
5. Allow unit to cool for a minimum of 45 minutes.
6. Reassemble the unit. Plug in vacuum and turn it on.

NOTE: Not all accessories come with all units. Please see the enclosed Quick Start Guide for your unit's configuration. To order additional accessories, visit sharkaccessories.com.

FIVE (5) YEAR LIMITED WARRANTY

The Five (5) Year Limited Warranty applies to purchases made from authorized retailers of **SharkNinja Operating LLC**. Warranty coverage applies to the original owner and to the original product only and is not transferable.

SharkNinja warrants that the unit shall be free from defects in material and workmanship for a period of five (5) years from the date of purchase when it is used under normal household conditions and maintained according to the requirements outlined in the Owner's Guide, subject to the following conditions and exclusions:

What is covered by this warranty?

1. The original unit and/or non-wearable components deemed defective, in SharkNinja's sole discretion, will be repaired or replaced up to five (5) years from the original purchase date.
2. In the event a replacement unit is issued, the warranty coverage ends six (6) months following the receipt date of the replacement unit or the remainder of the existing warranty, whichever is later. SharkNinja reserves the right to replace the unit with one of equal or greater value.

What is not covered by this warranty?

1. Normal wear and tear of wearable parts (such as foam filters, HEPA filters, pads, etc.), which require regular maintenance and/or replacement to ensure the proper functioning of your unit, are not covered by this warranty. Replacement parts are available for purchase at sharkaccessories.com.
2. Any unit that has been tampered with or used for commercial purposes.
3. Damage caused by misuse (e.g., vacuuming up water or other liquids), abuse, negligent handling, failure to perform required maintenance (e.g., not cleaning the filters), or damage due to mishandling in transit.
4. Consequential and incidental damages.
5. Defects caused by repair persons not authorized by SharkNinja. These defects include damages caused in the process of shipping, altering, or repairing the SharkNinja product (or any of its parts) when the repair is performed by a repair person not authorized by SharkNinja.
6. Products purchased, used, or operated outside North America.

How to get service

If your appliance fails to operate properly while in use under normal household conditions within the warranty period, visit sharkclean.com/support for product care and maintenance self-help. Our Customer Service Specialists are also available at **1-800-798-7398** to assist with product support and warranty service options, including the possibility of upgrading to our VIP warranty service options for select product categories.

SharkNinja will cover the cost for the customer to send in the unit to us for repair or replacement. A fee of \$24.95 (subject to change) will be charged when SharkNinja ships the repaired or replacement unit.

How to initiate a warranty claim

You must call **1-800-798-7398** to initiate a warranty claim. You will need the receipt as proof of purchase. A Customer Service Specialist will provide you with return and packing instruction information.

How state law applies

This warranty gives you specific legal rights, and you also may have other rights that vary from state to state. Some states do not permit the exclusion or limitation of incidental or consequential damages, so the above may not apply to you.

REGISTER YOUR PURCHASE

 registeryourshark.com

 Scan QR code using mobile device



Benefits of registering your product and creating an account:

- Get easier, faster product support and access to warranty information
- Access troubleshooting and product care instructions
- Be among the first to know about exclusive product promotions

TIP: You can find the model and serial numbers on the QR code label on the bottom of the back of the vacuum pod.

RECORD THIS INFORMATION

Model Number: _____

Serial Number: _____

Date of Purchase: _____
(Keep receipt)

Store of Purchase: _____

TECHNICAL SPECIFICATIONS

Voltage: 120V~, 60Hz

Watts: 1100W

Amps: 9.2A

PLEASE READ CAREFULLY AND KEEP FOR FUTURE REFERENCE.

This Owner's Guide is designed to help you get a complete understanding of your new Shark® Rotator® Powered Lift-Away® Speed with Self-Cleaning Brushroll.

SharkNinja Operating LLC
US: Needham, MA 02494
CAN: Ville St-Laurent, QC H4S 1A7
1-800-798-7398
sharkclean.com

Illustrations may differ from actual product. We are constantly striving to improve our products; therefore the specifications contained herein are subject to change without notice.

For SharkNinja U.S. Patent information, visit sharkninja.com/uspatents

