

Shark[®]

Rocket[®] Corded Ultra-Light Vacuum

ZS340 Series

OWNER'S GUIDE

duo clean[®]

ZERO·M

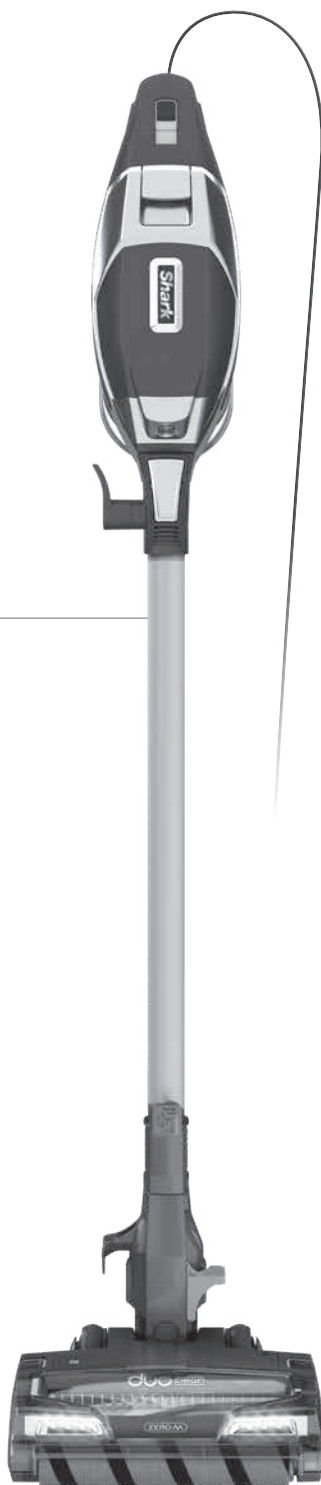

IMPORTANT SAFETY INSTRUCTIONS

HOUSEHOLD USE ONLY

To reduce the risk of electric shock, this vacuum cleaner has a polarized plug (one blade is wider than the other). As a safety feature, this plug will fit into a polarized outlet only one way. If the plug does not fit fully into the outlet, reverse the plug. If it still does not fit, contact a qualified electrician. **DO NOT force into outlet or try to modify to fit.**

⚠ WARNING

TO REDUCE THE RISK OF FIRE, ELECTRIC SHOCK OR INJURY:

GENERAL WARNINGS

1. Your vacuum cleaner may consist of a motorized nozzle, wand, hose, and/or vacuum pod. This device contains electrical connections, electrical wiring, and moving parts that potentially present risk to the user.
2. Use only identical replacement parts.
3. Carefully observe and follow the instructions provided below to avoid improper use of the appliance. **DO NOT** use the vacuum for any purpose other than those described in this manual.
4. Before use, carefully inspect all parts for any damage. **DO NOT** use if any parts are damaged.
5. The use of an extension cord is **NOT** recommended.
6. This vacuum cleaner contains no serviceable parts.

USE WARNINGS

7. **DO NOT** allow the appliance to be used by children. Close supervision is necessary when used near children. This is not a toy.
8. Always turn off the vacuum cleaner before connecting or disconnecting any motorized nozzles or other accessories.
9. **DO NOT** handle plug or vacuum cleaner with wet hands.
10. **DO NOT** use without filters in place.

11. Only use Shark® branded filters and accessories. Failure to do so will also void the warranty.
12. **DO NOT** damage the power cord:
 - a) **DO NOT** pull or carry vacuum cleaner by the cord or use the cord as a handle.
 - b) **DO NOT** unplug by pulling on cord. Grasp the plug, not the cord.
 - c) **DO NOT** run the vacuum cleaner over the power cord, close a door on the cord, pull the cord around sharp corners, or leave the cord near heated surfaces.
13. **DO NOT** put any objects into nozzle or accessory openings. **DO NOT** use with any opening blocked; keep free of dust, lint, hair, and anything that may reduce airflow.
14. **DO NOT** use if nozzle or accessory airflow is restricted. If the air paths or the motorized floor nozzle become blocked, turn the vacuum cleaner off and unplug from electrical outlet. Remove all obstructions before you plug in and turn on the unit again.
15. Keep nozzle and all vacuum openings away from hair, face, fingers, uncovered feet, or loose clothing.
16. **DO NOT** use if vacuum cleaner is not working as it should, or has been dropped, damaged, left outdoors, or dropped into water.

SAVE THESE INSTRUCTIONS

READ ALL INSTRUCTIONS BEFORE USE

17. Use extra care when cleaning on stairs.
18. **DO NOT** leave the vacuum cleaner unattended while plugged in.
19. When powered on, keep the vacuum cleaner moving over the carpet surface at all times to avoid damaging the carpet fibers.
20. **DO NOT** place vacuum cleaner on unstable surfaces such as chairs or tables.
21. Your Shark® vacuum may not be designed to stand up on its own. When taking a break from cleaning, you may need to lean it against furniture or a wall, or lay it flat on the floor. Using the vacuum for an application where the unit lacks stability may result in personal injury.
22. **DO NOT** use to pick up:
 - a) Liquids
 - b) Large objects
 - c) Hard or sharp objects (glass, nails, screws, or coins)
 - d) Large quantities of dust (drywall dust, fireplace ash, or embers). **DO NOT** use as an attachment to power tools for dust collection.
 - e) Smoking or burning objects (hot coals, cigarette butts, or matches)
 - f) Flammable or combustible materials (lighter fluid, gasoline, or kerosene)
 - g) Toxic materials (chlorine bleach, ammonia, or drain cleaner)
23. **DO NOT** use in the following areas:
 - a) Poorly lit areas
 - b) Wet or damp surfaces
 - c) Outdoor areas
 - d) Spaces that are enclosed and may contain explosive or toxic fumes or vapors (lighter fluid, gasoline, kerosene, paint, paint thinners, mothproofing substances, or flammable dust)
24. Turn off all controls before plugging in or unplugging the vacuum.
25. Unplug from electrical outlet when not in use and before any maintenance or cleaning.
26. Hand wash with water only. Washing with cleaning chemicals could damage the unit.
27. During cleaning or routine maintenance, **DO NOT** cut anything other than hair, fibers, or string wrapped around the brushroll.
28. Allow all filters to air-dry completely before replacing in the vacuum to prevent liquid from being drawn into electric parts.
29. Make sure the dust cup and all filters are in place after routine maintenance.
30. If provided, secure the power cord around the two cord hooks during storage.

ASSEMBLY

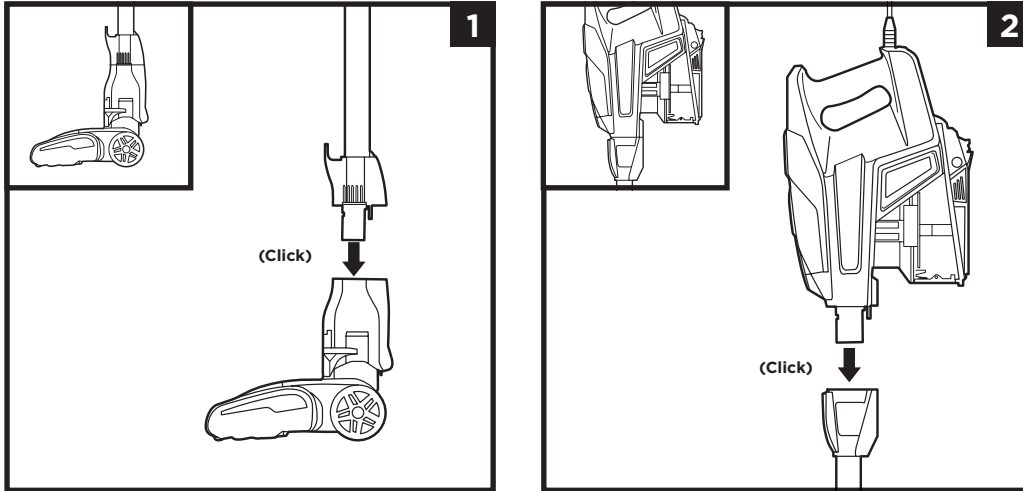

1. Insert **Wand** into **Floor Nozzle**.

2. Insert **Handheld Vacuum** into wand.

Ensure all connections click securely into place.

SETTINGS



OFF

Slide switch to the bottom to turn off power. To begin vacuuming, slide switch to the appropriate setting.

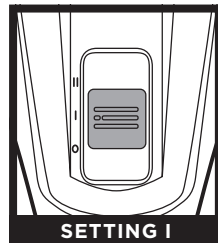

SETTING I

Bare Floor/Small Area Rugs The brushrolls spin slowly to clean bare floors and small area rugs.

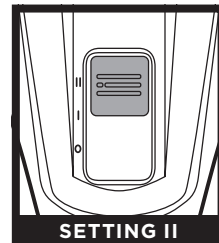

SETTING II

Carpet The brushrolls spin faster to pick up debris below the surface of your carpets.

NOTE: For deep cleaning per ASTM F 608 (embedded dirt in carpets) please use setting II, Carpet.

NOTE: Select Carpet for stuck-on dust and debris.

CLEANING MODES

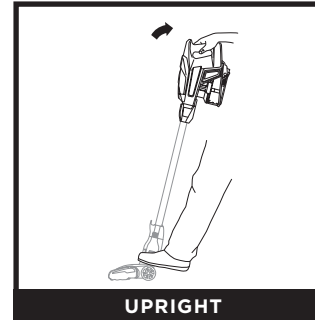

UPRIGHT

To clean floors, place foot on floor nozzle and tilt handheld vacuum back.

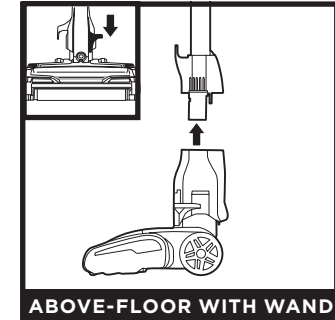

ABOVE-FLOOR WITH WAND

Detach the wand for more reach to clean baseboards, ceiling fans, window sills, and other hard-to-access areas. Stand the vacuum upright, then step on the foot pedal on the left side of the floor nozzle and pull the wand up to disconnect it.

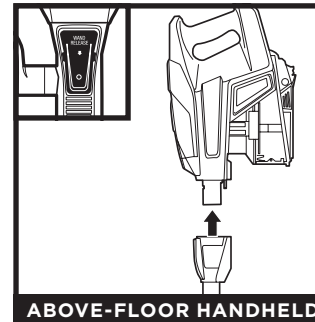

ABOVE-FLOOR HANDHELD

Press the **WAND RELEASE** button and lift the handheld vacuum off the wand. Great for cleaning stairs and furniture.

WHAT DOES THE BRUSHROLL INDICATOR LIGHT MEAN?

Solid Green

The brushroll is on and working as it should.

Solid Red

There is a jam in the brushroll area. Turn your vacuum off and remove the blockage.

No Light: The vacuum is off.

Flashing Red: The vacuum has overheated. See Troubleshooting section.

NOTE: All accessories are compatible with both the wand and the handheld vacuum.

STORAGE

ONBOARD HOOK

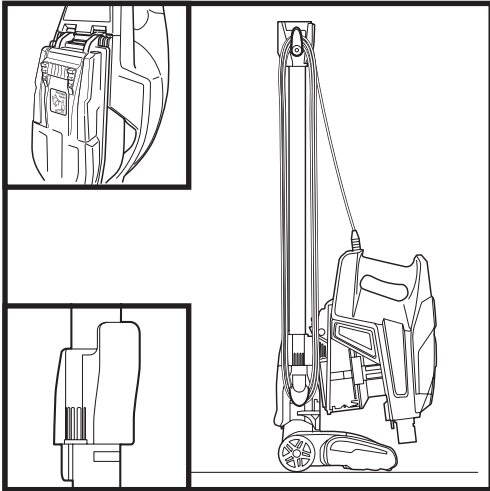

Press the WAND RELEASE button on the top of the wand to detach the handheld vacuum. Align the catch on the bottom of the handheld vacuum with the storage hook on the wand. Slide the handheld vacuum down so the catch hangs from the storage hook. Wrap the cord around the two cord hooks.

WALL MOUNT

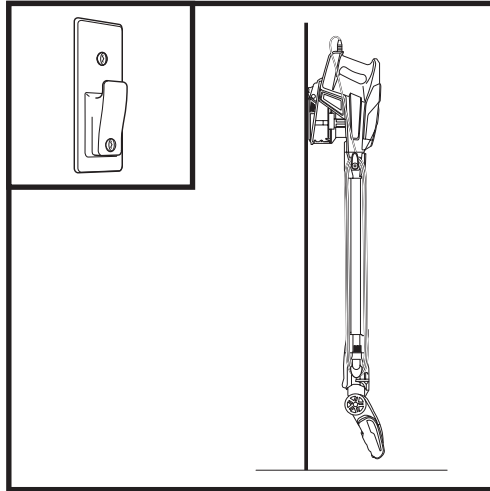

For convenient storage above the floor, a wall mount is available for purchase on sharkaccessories.com. It comes with an instruction sheet, hardware, and a mounting template.

AVAILABLE ACCESSORIES

NOTE: Not all accessories come with all units. Please see the enclosed Quick Start Guide for your unit's configuration. To order additional accessories, visit sharkaccessories.com.

- A 5" Crevice Tool**
This slender 5" tool can access corners, baseboards, tight spaces, and ceilings.
- B 12" Crevice Tool**
Clean in tight spaces or reach baseboards and ceilings with this slim crevice tool.
- C Dusting Brush**
Dust shelves, baseboards, window and door frames, and much more. Turn the brush head to adjust the angle to the surface you're cleaning.
- D Pet/Upholstery Tool**
Perfect for grabbing pet hair and lint from furniture and other upholstered surfaces.
- E Pet Multi-Tool**
A single convertible tool for cleaning tough pet messes two ways: first, a stiff bristle brush for cleaning stuck-on debris. Then take off the bristles to reveal an upholstery tool for removing stubborn pet hair.
- F Duster Crevice Tool**
Two cleaning tools in one. The crevice tool gives you extended cleaning reach for small spaces, while the dusting brush cleans a multitude of surfaces.
- G Mini Motorized Brush**
Powered by a motor, this small brush removes the clingiest pet hair and extracts dirt, dust, dander, and allergens from deep inside pillows, upholstery, and carpets.
- H Under-Appliance Wand**
Clean under and behind hard-to-move appliances and furniture with this adjustable 36" tool. Flip the extension piece over to clean the underside of appliances.
- I Flexible Hose**
Stretch and flex this extension hose to clean around objects and get into hard-to-reach spaces. Attach the crevice tool or another accessory depending on what you are cleaning.
- J Wall Mount**
Install the mount to hang your vacuum on the wall for convenient storage. Includes screws, anchors, and instruction sheet with mounting template for easy installation.
- K Onboard Storage Clip**
Removable clip attaches to the vacuum wand. Can hold up to two accessories at a time while cleaning or for storage.

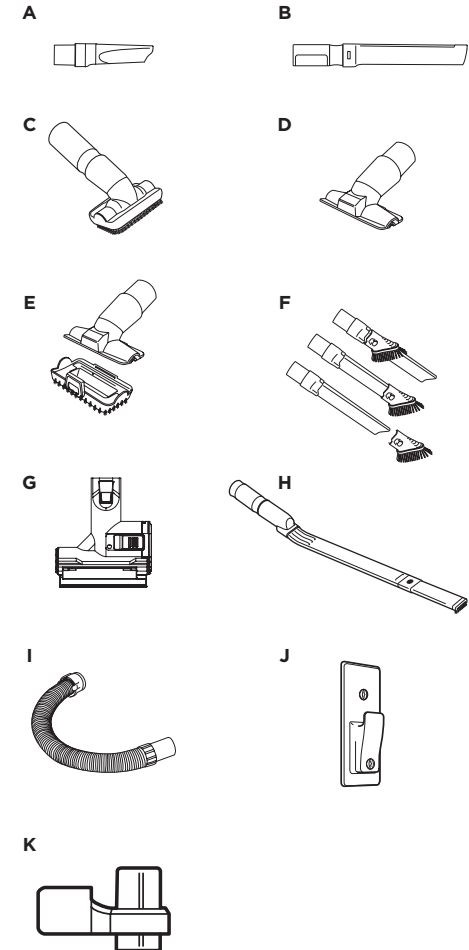

MAINTENANCE

IMPORTANT: Unplug the vacuum before performing any maintenance.

EMPTYING THE DUST CUP

Empty the dust cup each time you vacuum and periodically during cleaning, when debris in the dust cup reaches the MAX fill line.

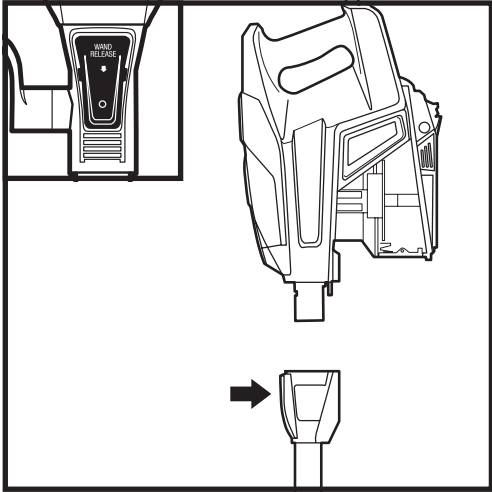

Press the WAND RELEASE button and lift the handheld vacuum off the wand.

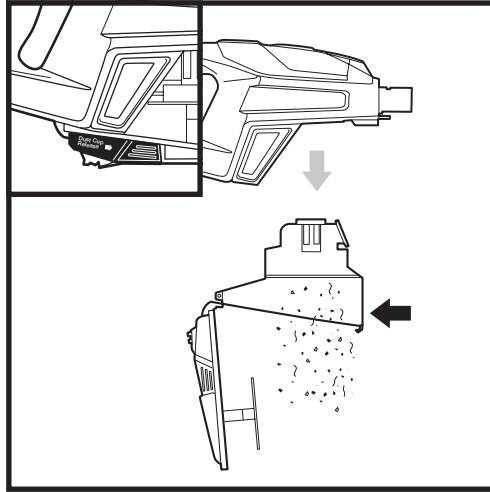

To remove the dust cup from the handheld vacuum, squeeze the two **Dust Cup Release** buttons at the same time and pull out the dust cup. Press the **Empty** button on the front of the dust cup.

OR

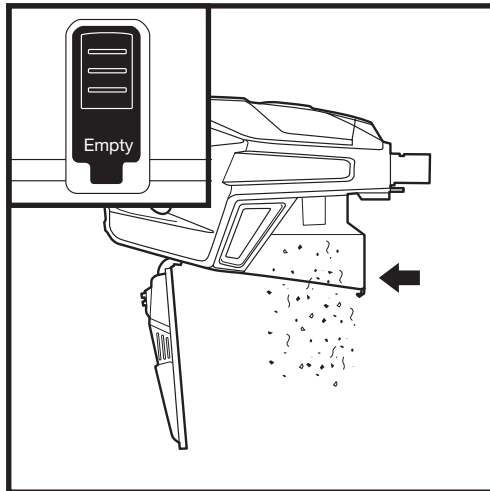

With the dust cup attached to the handheld vacuum, press the **Empty** button on the front of the dust cup.

MAINTENANCE

IMPORTANT: Unplug the vacuum before performing any maintenance.

CLEANING FILTERS

Perform regular maintenance on your filters to keep your vacuum's suction power optimal.

IMPORTANT: To prevent damage, rinse filters with water **ONLY**. **DO NOT** use soap. Allow filters to air-dry for at least 24 hours before reinstalling them to prevent liquid from being drawn into electric parts.

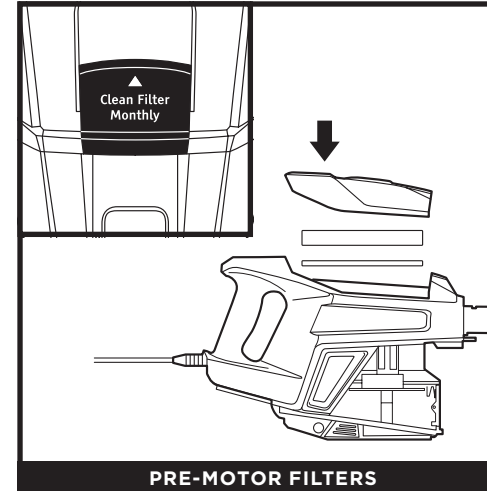

PRE-MOTOR FILTERS

The **Pre-Motor Filters** should be washed once a month.

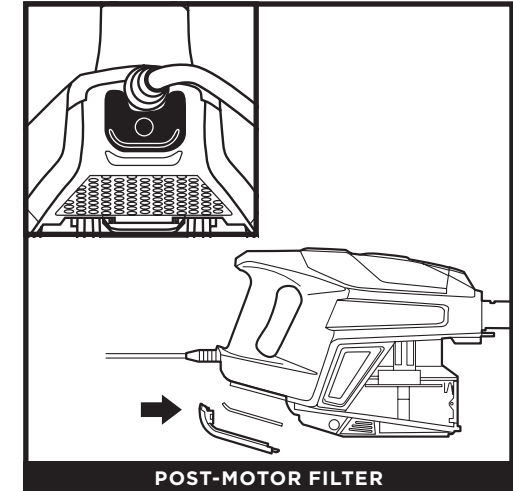

POST-MOTOR FILTER

The **Post-Motor Filter** should be washed once every 9 months.

REPLACEMENT FILTERS

Replacement Pre-Motor Filter Kit
XPMFK320

Replacement Post-Motor Filter
1084FTV320

NOTE: The pre-motor filters should be replaced every 2.5 years. The post-motor filter should be replaced every 3 years.

MAINTENANCE

CHECKING FOR BLOCKAGES

CHECK HANDHELD

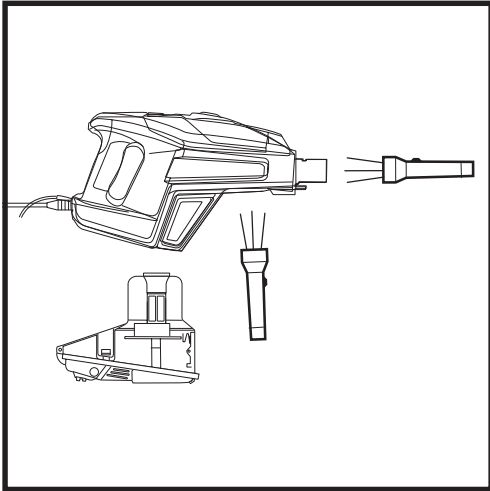

Remove the wand from the handheld vacuum and check all dust cup intake openings.

CHECK WAND

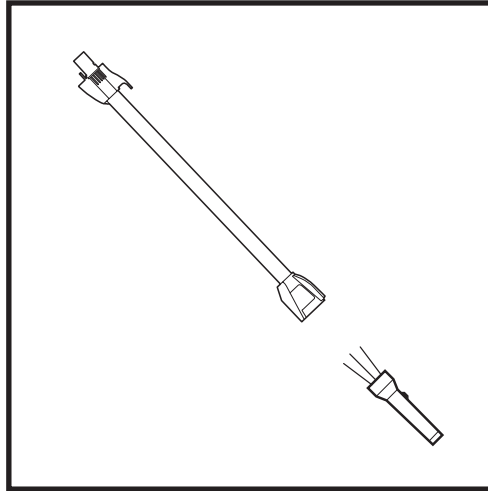

Detach the wand and check it for blockages.

CHECK FLOOR NOZZLE

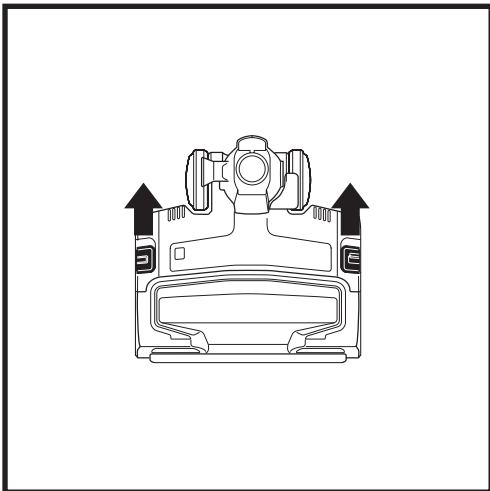

Detach the wand. To open the brushroll garage, slide both release buttons on the floor nozzle away from you, towards the back of the nozzle, then lift off the lid.

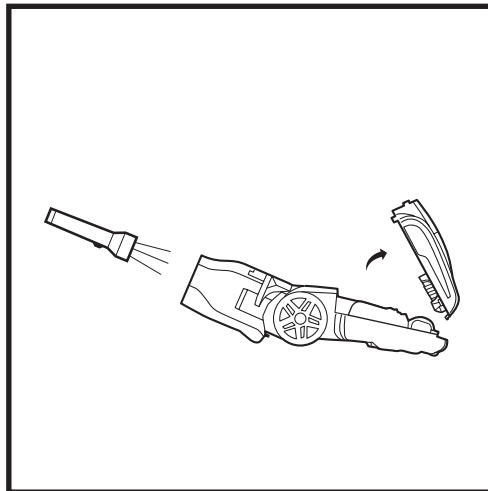

Tilt back the neck of the nozzle and check openings for blockages. To close the brushroll garage, insert the 3 tabs on top of lid into the 3 slots in the nozzle, then push down firmly on both sides of the lid until it clicks securely into place.

MAINTENANCE

NOZZLE MAINTENANCE

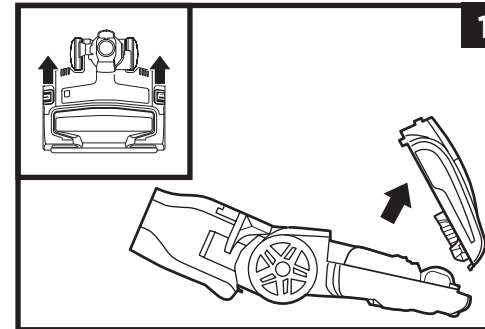

CLEANING THE BRUSHROLL

- 1 To open the brushroll garage, slide both release buttons on the floor nozzle away from you, towards the back of the nozzle, then lift off the lid.
- 2 Clear away any objects or debris.
- 3 To close the brushroll garage, insert the 3 tabs on top of lid into the 3 slots in the nozzle, then push down on both sides of lid until it clicks securely into place. **If Brushroll Indicator Light isn't green and headlights are flashing, check again that both sides of lid are locked in place.**

NOTE: If any hair is wrapped around the brushroll, continue cleaning, using **Carpet** mode on a bare floor surface, a low-pile carpet, or a small area rug. This will allow Zero-M* technology to remove the hair wrap and send it to the dust cup. If some fibers remain wrapped around the brushroll after continued use, carefully remove them.

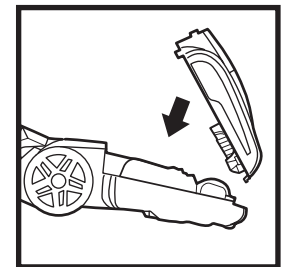
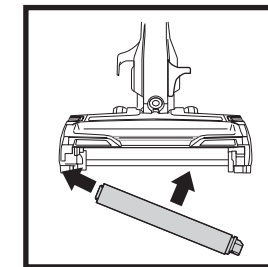
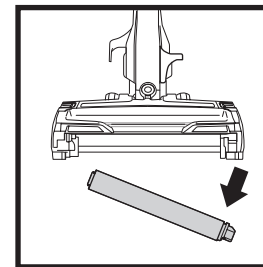
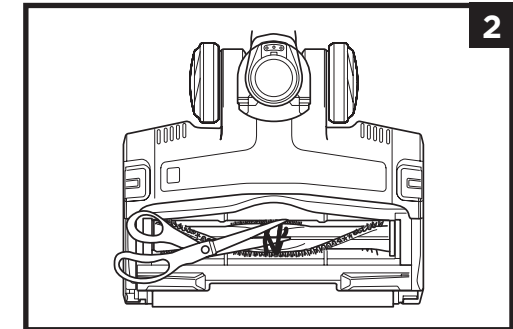

CLEANING THE SOFT ROLLER

- 1 To remove Soft Roller from nozzle, first open the brushroll garage, then pull the Soft Roller out by the tab.
- 2 Tap loose debris off the Soft Roller. Use a dry towel to wipe the Soft Roller clean, and to remove any debris caught in the teeth behind the Soft Roller.
- 3 Hand wash the Soft Roller as needed. Use only water, and let air-dry completely for at least 24 hours.
- 4 Reinsert the Soft Roller and close the brushroll garage by inserting the 3 tabs on top of the lid into the 3 slots in the nozzle. Then push down on both sides of the lid until it clicks securely into place. **If Brushroll Indicator Light isn't green and headlights are flashing, check again that both sides of the lid are locked in place.**

NOTE: With normal use, you may need to perform routine maintenance of your Soft Roller.

TROUBLESHOOTING

Vacuum is not picking up debris. No suction or light suction.
(Refer to Maintenance section for more information.)

- Check filters to see if they need cleaning. Follow instructions for rinsing and completely air-drying the filters before reinserting in the vacuum.
- Dust cup may be full; empty dust cup.
- Check floor nozzle for blockages; clear blockages if required.
- Remove any string, carpet fibers, or hair that may be wrapped around the brushroll or Soft Roller.
- Ensure the brushroll garage is locked in place by pushing down on both sides of the lid until it clicks securely into place.

Vacuum lifts area rugs.

- Suction is powerful. Take care when vacuuming area rugs or rugs with delicately sewn edges.
- Turn off the unit to disengage the brushrolls. To restart, slide the power switch to setting I, Bare Floor/ Small Area Rugs.

Brushrolls do not spin.

- If the Brushroll Indicator Light turns red, immediately turn off and unplug the vacuum. Disconnect wand from floor nozzle and clear any blockages. Reconnect wand, plug in vacuum, and turn on power.
- If Brushroll Indicator Light on the floor nozzle is green, the blockage has been successfully cleared. If the light is still red, please contact Customer Service at 1-800-798-7398.

Vacuum turns off on its own or the indicator light flashes red.

This vacuum is equipped with a motor-protective thermostat so it will shut off if it overheats. Should this occur, perform the following steps to restart the motor-protective thermostat:

1. Turn vacuum off and unplug it.
2. Empty dust cup and clean filters (see Maintenance section).
3. Check for blockages in hose, accessories, and inlet openings.
4. Allow unit to cool for a minimum of 45 minutes.
5. Plug in vacuum and turn it on.

For all other issues, visit sharkclean.com/support.

REGISTER YOUR PURCHASE



registeryourshark.com



Scan QR code using mobile device



Benefits of registering your product and creating an account:

- Get easier, faster product support and access to warranty information
- Access troubleshooting and product care instructions
- Be among the first to know about exclusive product promotions

TIP: The model number is on the rating label behind the dust cup.

TIP: The date code is on one of the prongs of the power cord plug.

RECORD THIS INFORMATION

Model Number: _____

Date Code: _____

Date of Purchase: _____
(Keep receipt)

Store of Purchase: _____

TECHNICAL SPECIFICATIONS

Voltage: 120V, 60Hz

Watts: 500W

Amps: 4.2A

Shark®

FIVE (5) YEAR LIMITED WARRANTY

The Five (5) Year Limited Warranty applies to purchases made from authorized retailers of **SharkNinja Operating LLC**. Warranty coverage applies to the original owner and to the original product only and is not transferable.

SharkNinja warrants that the unit shall be free from defects in material and workmanship for a period of five (5) years from the date of purchase when it is used under normal household conditions and maintained according to the requirements outlined in the Owner's Guide, subject to the following conditions and exclusions:

What is covered by this warranty?

1. The original unit and/or non-wearable components deemed defective, in SharkNinja's sole discretion, will be repaired or replaced up to five (5) years from the original purchase date.
2. In the event a replacement unit is issued, the warranty coverage ends six (6) months following the receipt date of the replacement unit or the remainder of the existing warranty, whichever is later. SharkNinja reserves the right to replace the unit with one of equal or greater value.

What is not covered by this warranty?

1. Normal wear and tear of wearable parts (such as foam filters, HEPA filters, pads, etc.), which require regular maintenance and/or replacement to ensure the proper functioning of your unit, are not covered by this warranty. Replacement parts are available for purchase at sharkaccessories.com.
2. Any unit that has been tampered with or used for commercial purposes.
3. Damage caused by misuse (e.g., vacuuming up water or other liquids), abuse, negligent handling, failure to perform required maintenance (e.g., not cleaning the filters), or damage due to mishandling in transit.
4. Consequential and incidental damages.
5. Defects caused by repair persons not authorized by SharkNinja. These defects include damages caused in the process of shipping, altering, or repairing the SharkNinja product (or any of its parts) when the repair is performed by a repair person not authorized by SharkNinja.
6. Products purchased, used, or operated outside North America.

How to get service

If your appliance fails to operate properly while in use under normal household conditions within the warranty period, visit sharkclean.com/support for product care and maintenance self-help. Our Customer Service Specialists are also available at **1-800-798-7398** to assist with product support and warranty service options, including the possibility of upgrading to our VIP warranty service options for select product categories.

SharkNinja will cover the cost for the customer to send in the unit to us for repair or replacement. A fee of \$24.95 (subject to change) will be charged when SharkNinja ships the repaired or replacement unit.

How to initiate a warranty claim

You must call **1-800-798-7398** to initiate a warranty claim. You will need the receipt as proof of purchase. A Customer Service Specialist will provide you with return and packing instruction information.

How state law applies

This warranty gives you specific legal rights, and you also may have other rights that vary from state to state. Some states do not permit the exclusion or limitation of incidental or consequential damages, so the above may not apply to you.

PLEASE READ CAREFULLY AND KEEP FOR FUTURE REFERENCE.

This Owner's Guide is designed to help you keep your Shark® Rocket® running at peak performance. Visit sharkclean.com for FAQs, how-to videos, and more.

SharkNinja Operating LLC
US: Needham, MA 02494
CAN: Ville St-Laurent, QC H4S 1A7
1-800-798-7398
sharkclean.com

Illustrations may differ from actual product. We are constantly striving to improve our products; therefore the specifications contained herein are subject to change without notice.

For SharkNinja U.S. Patent information, visit sharkninja.com/uspatents

© 2019 SharkNinja Operating LLC. DUOCLEAN, ROCKET, SHARK, and ZERO-M are registered trademarks of SharkNinja Operating LLC.

ZS340_Series_IB_E_EB1_Mv8
PRINTED IN CHINA



@sharkcleaning