

Shark[®]

V2700Z

OWNER'S GUIDE

www.sharkclean.com



IMPORTANT SAFETY INSTRUCTIONS

For Household Use Only

READ ALL INSTRUCTIONS BEFORE USING YOUR SHARK® CORDLESS FLOOR AND CARPET SWEEPER.

WHEN USING YOUR SHARK CORDLESS FLOOR AND CARPET SWEEPER, BASIC SAFETY PRECAUTIONS SHOULD ALWAYS BE OBSERVED, INCLUDING THE FOLLOWING:

WARNING: TO REDUCE THE RISK OF FIRE, ELECTRIC SHOCK OR INJURY:

- 1 Read and follow all label, operational and marking instructions.
- 2 Use **ONLY** as described in this manual. Use only manufacturer's recommended attachments.
- 3 **DO NOT** allow to be used as a toy. Close attention is necessary when used by or near children.
- 4 **DO NOT** use for any purpose other than described in this user's guide.
- 5 **DO NOT** use with damaged cord or plug. Do not use the cordless floor and carpet sweeper if it has been dropped, damaged, left outdoors, or dropped in water. Return it to EURO-PRO Operating LLC for examination, repair or adjustment.
- 6 **DO NOT** abuse the charger cord. Never carry the charger or base by the cord or yank to disconnect from an outlet; instead grasp the charger and pull to disconnect.
- 7 Keep the charger cord away from heated surfaces.
- 8 **DO NOT** use the charger with an extension cord. Plug the charger directly into an electrical outlet. Use charger only in a standard (120V., 60Hz.) electrical outlet.
- 9 **DO NOT** attempt to use the charger with any other product or attempt to charge this product with another charger. **Use only the charger model YLS0041-T080020 supplied with this cordless floor and carpet sweeper.**
- 10 **DO NOT** charge this unit outdoors.
- 11 **DO NOT** use outdoors or on wet surfaces.
- 12 **DO NOT** handle plug or appliance with wet hands.
- 13 Use only on dry, indoor surfaces.
- 14 **DO NOT** put any object into openings. Do not use with brush roll blocked; keep free of fiber, lint, hair and anything that may prevent the brush roll from working.
- 15 Keep hair, loose clothing, fingers and all parts of body away from openings and moving parts.
- 16 **DO NOT** pick up anything that is burning or smoking, such as cigarettes, matches or hot ashes.
- 17 **DO NOT** use to pick up flammable or combustible liquids such as gasoline or use in areas where they may be present.
- 18 **DO NOT** attempt to change accessories while the unit is running.
- 19 **DO NOT** use the cordless floor and carpet sweeper without the dust container in place.
- 20 Use extra care when cleaning on stairs.
- 21 Store the cordless floor and carpet sweeper indoors. Store after use to prevent accidents.
- 22 Leaks from battery cells can occur under extreme conditions. If the liquid, which is 20-35% solution of potassium hydroxide, gets on the skin - wash immediately with soap and water or neutralize with a mild acid such as lemon juice or vinegar. If the liquid gets into the eyes, flush them immediately with clean water for a minimum of 10 minutes and seek medical attention.
- 23 This product includes rechargeable nickel metal hydride batteries. Batteries must be recycled or disposed of properly. Do not incinerate the batteries or expose to high temperatures as they may explode.
- 24 The cordless floor and carpet sweeper must be disconnected from the power supply when removing the battery.
- 25 To reduce the risk of electrical shock, do not put the charger and sweeper body in water or other liquid. Do not place or store the appliance where it can fall or be pulled into a tub or sink.



**TO MAXIMIZE THE LIFE OF YOUR
NI-MH BATTERIES:**

- 1 Charge for 7 hours before initial use. Failure to do so will reduce the product's battery life significantly.
- 2 For best battery performance, remove the charging adapter from the unit after the charging period has completed.
- 3 **Do not store the unit with the charging adapter attached and plugged in.**
- 4 For maximum battery life, only recharge the unit when the batteries are close to fully discharged. It is best to fully discharge the batteries at least once a month.
- 5 **DO NOT** store in areas of high temperature or humidity.
- 6 After 3 months of non-use, the product should be fully discharged and then recharged to maximize battery power.
- 7 Ni-MH batteries have a long useful life but at some time they will need to be replaced. To purchase replacement batteries, visit www.sharkclean.com.

⚠ NOTE: The power button must be in the "Off" position in order to charge the unit. If the charging indicator does not light, press the power button once.

Warning: Changes or modifications to this unit not expressly approved by the party responsible for compliance could void the user's authority to operate the equipment.

Note: This equipment has been tested and found to comply with the limits for a Class B digital device, pursuant to Part 15 of the FCC Rules. These limits are designed to provide reasonable protection against harmful interference in a residential installation. This equipment generates, uses and can radiate radio frequency energy and, if not installed and used in accordance with the instructions, may cause harmful interference to radio communications.

However, there is no guarantee that interference will not occur in a particular installation. If this equipment does cause harmful interference to radio or television reception, which can be determined by turning the equipment off and on, the user is encouraged to try to correct the interference by one or more of the following measures:

- Reorient or relocate the receiving antenna.
- Increase the separation between the equipment and receiver.
- Connect the equipment into an outlet on a circuit different from that to which the receiver is connected.
- Consult the dealer or an experienced radio/TV technician for help.

This device complies with Part 15 of the FCC Rules. Operation is subject to the following two conditions: (1) This device may not cause harmful interference, and (2) this device must accept any interference received, including interference that may cause undesired operation.

SAVE THESE INSTRUCTIONS

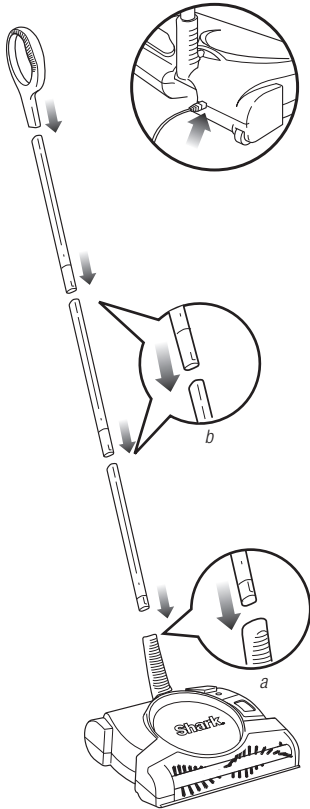

Fig. 1

IMPORTANT: Before you can start using your new cordless floor and carpet sweeper, charge it for 7 hours.

NOTE: The charging adapter will be shipped inside the packaging.



Fig. 2

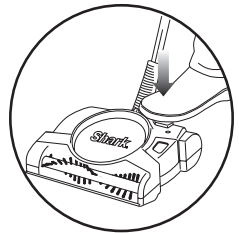

Fig. 3

ASSEMBLE

- 1 Insert the lower handle extension tube (the shortest of the three tubes) into the lower handle (a). Then assemble the other two extension tubes and insert the assembly into the lower handle extension tube (b). Now attach the upper handle to the top extension tube. (Fig. 1)

CLEAN

- 2 Pull back on the handle and press lightly on the body of the unit with your foot to engage the steering. (Fig. 2)
- 3 Using your foot, press the power button and push the unit forward over the surface you wish to clean. (Fig. 3)

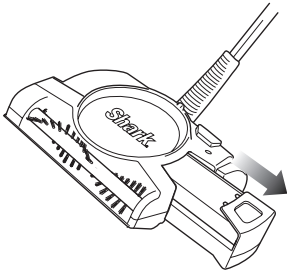

Fig. 4

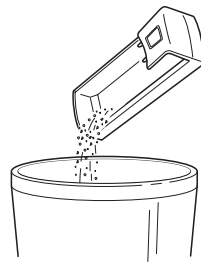

Fig. 5

EMPTY

- 4 When you're finished cleaning, pull the dust container straight out from the side. (Fig. 4)

NOTE: Be careful not to accidentally turn the unit on.

- 5 Empty dust container contents. (Fig. 5) If desired, you may rinse with water to clean the dust container - but dry thoroughly before replacing. When finished, replace the dust container.

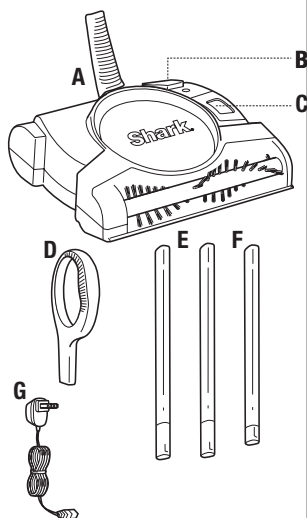

COMPONENTS:

- A** Main Unit
- B** Power Button
- C** Dust Container
- D** Upper Handle
- E** Extension Tubes (x2)
- F** Lower Handle Extension Tube
- G** Charging Adapter

Model Number: V2700Z 32

Voltage: 4.8 V

ASSEMBLY OF YOUR FLOOR AND CARPET SWEEPER:

- ⚠ NOTE:** The charging adapter will be shipped inside the packaging.
- ⚠ IMPORTANT:** Charge the batteries for 7 hours before using the unit for the first time. See page 7 for instructions on charging your unit.

- 1** Insert the lower handle extension tube (the shortest of the three tubes) into the lower handle (a). Then assemble the other two extension tubes and insert the assembly into the lower handle extension tube (b). Now attach the upper handle to the top extension tube. (Fig. 1)

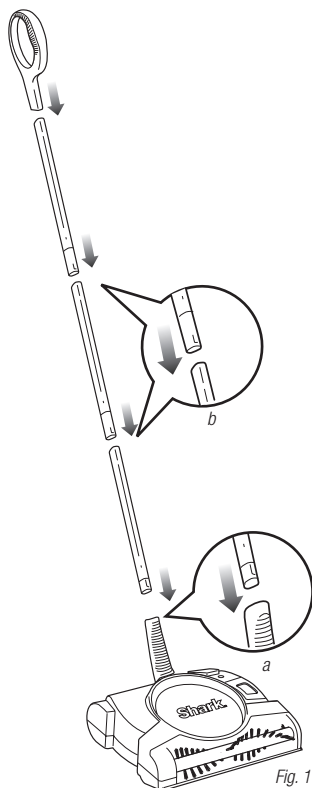

CHARGING YOUR CORDLESS FLOOR AND CARPET SWEEPER

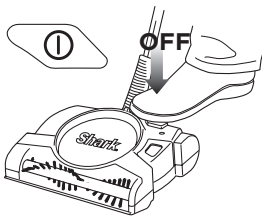

Fig. 2

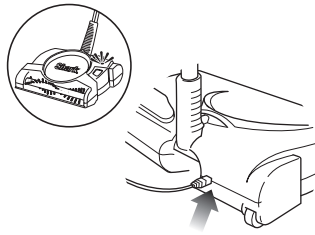

Fig. 3

- 1 Always make sure that the unit is turned off. (Fig. 2)
 - 2 Insert the charger plug into the hole on the back of the unit. Plug the charger into a wall outlet. The light next to the power button will illuminate when the unit is charging. If the unit is plugged in and the light is not illuminated, press the power button once. The light should now be illuminated indicating that the unit is charging. (Fig. 3) Once the charge is completed, the light will go off.
 - 3 Charge the battery for 7 hours before initial use and 7 hours for each recharge. Our cordless floor and carpet sweeper is powered by Ni-MH batteries that need this time to build up their charge.
 - 4 For best battery performance, remove the charging adapter from the unit after the charging period has completed.
- Storing the unit with the adapter attached and plugged in will reduce the battery life.**

IMPORTANT: Although many adapters look similar, it's important to use only the adapter that came with the unit (XA2700).

USING YOUR CORDLESS FLOOR AND CARPET SWEEPER

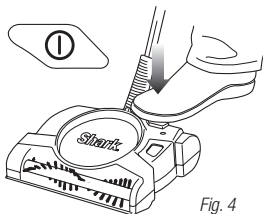

Fig. 4

- 1 Press the power button to start the unit. When finished cleaning, press the power button again to turn the unit off. (Fig. 4)
- 2 Do not use the unit to pick up liquids or clean wet floors.
- 3 Do not use the unit on concrete, tar or other rough surfaces.
- 4 Do not use the unit to pick up pieces of string or fabrics. Do not use the unit to clean tasseled or frayed carpets.

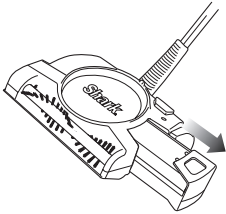

Fig. 5



Fig. 6

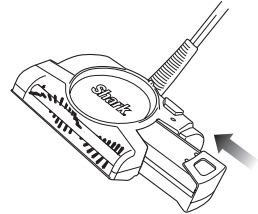

Fig. 7

- 1** To achieve the best performance, empty the dust container after each use. Pull the dust container straight out from the side. (Fig. 5)

⚠ NOTE: Be careful not to accidentally turn the unit on.

- 2** Empty dust container contents. (Fig. 6) If desired, you may rinse with water to clean the dust container - but dry thoroughly before replacing.

- 3** Re-insert the dust container into the unit. (Fig. 7)

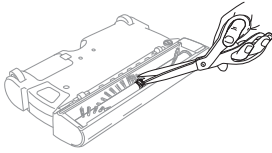

Fig. 8

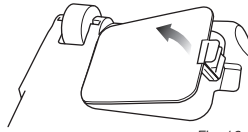

Fig. 10

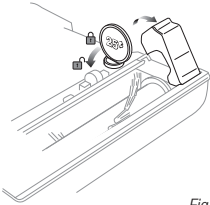

Fig. 9

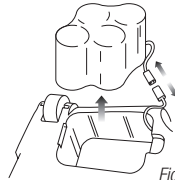

Fig. 11

⚠ CAUTION: Do not clean the unit while it is charging.

- 1 Once a month, wipe down the unit with a dry cloth, including the area under the dust container. Wipe away any hair, fiber or other dirt that may have built up in the chamber and on the rotating brush. Do not use any harsh cleaner or chemicals.
- 2 Do not immerse the unit in water.

CLEANING THE ROTATING BRUSH

- 1 Pull the dust container straight out from the side of the unit to remove. (Fig. 5)
- 2 Turn the unit upside down. **Be careful not to accidentally turn the unit on!**
- 3 Remove all hair, string or fibers wrapped around the brush bar. Using a pair of scissors, carefully cut along the raised guide to remove anything wound around the brush bar. Avoid damaging or cutting the bristles. (Fig. 8)

- 4 Use a coin to remove the trap door if you need to remove the brushroll to either clean it or replace it. (Fig. 9)

REMOVING AND REPLACING THE BATTERY

⚠ NOTE: If uncertain as to how to remove your battery pack, we suggest you take the unit to a reputable small appliance service technician to have this service performed.

- 1 Pull the dust container straight out from the side of the unit to remove. (Fig. 5)
- 2 Turn the unit upside down. **Be careful not to accidentally turn the unit on!**
- 3 Push in the locking tab and lift off the battery compartment cover. (Fig. 10)
- 4 Carefully lift out the battery pack and disconnect the wire terminals by pressing on the latch and pulling apart the wire terminal connectors. Remove the battery pack. (Fig. 11)

- 5 Connect the wire terminal from the unit to the wire terminal connector of the new battery pack and replace the battery pack into the unit. Replace the battery compartment cover.

- 6 Follow the instructions on page 7 to charge your new battery pack. Please call customer service at 1-800-798-7398 if you have any problems removing the battery pack.

⚠ IMPORTANT This appliance contains Ni-MH batteries. The batteries must be recycled or disposed of in accordance with local regulations. Please consult your Yellow Pages or local recycling center for more information.

⚠ WARNING: Never use ordinary batteries for replacement as these may leak and cause damage. Use only battery pack **XB2700** for replacement.



**NI-MH BATTERY
MUST BE RECYCLED
OR DISPOSED OF
PROPERLY**

PROBLEM

POSSIBLE REASONS AND SUGGESTED SOLUTION

The unit will not operate

Batteries need to be recharged.
Batteries are dead and need to be replaced.
There is no power in the electrical outlet supplying the charging adapter.
Try to charge using a different outlet.
Ensure the wire terminal connectors on the battery pack are securely attached.
If the unit still doesn't work, call Customer Service at **1-800-798-7398**.

The unit will not pick up

Empty the dust container.
Recharge the battery.

Dust is escaping from the unit

Empty the dust container.
Ensure that the dust container is properly in place.

The rotating brush will not pick up

Check for and remove any excessive material on the brush roll or in the bottom of the unit.
Empty the dust container.

The unit will not charge

Press the power button once to turn the unit "OFF".
There is no power in the electrical outlet supplying the charging adapter.
Try to charge using a different outlet.
Ensure the wire terminal connectors on the battery pack are securely attached.
Charging adapter may not be working. Call Customer Service at **1-800-798-7398**.
Batteries are dead and need to be replaced.

ORDERING REPLACEMENT PARTS

REPLACEMENT PARTS

- A** XB2700 Battery Pack
- B** XA2700 AC Adapter
- C** 1120FK-2700 Brush Bar Replacement Kit

To order any of the above replacement parts, go to www.sharkclean.com or call **1-800-798-7398**.

EURO-PRO ONE-YEAR (1) LIMITED WARRANTY

EURO-PRO Operating LLC warrants this product to be free from material defects and workmanship for a period of one (1) year from the date of purchase when utilized for normal household use, subject to the following conditions, exclusions and exceptions.

The liability of **EURO-PRO Operating LLC** is limited solely to the cost of the repair or replacement of the unit at our option. This Limited Warranty does not cover normal wear of parts and does not apply to any unit that has been tampered with or used for commercial purposes. This Limited Warranty does not cover damage caused by misuse, abuse, negligent handling or damage due to faulty packaging or mishandling in transit. This Limited Warranty does not cover damage or defects caused by or resulting from damages from shipping or repairs, service or alteration to the product or any of its parts, which have been performed by a repair person not authorized by **EURO-PRO Operating LLC**.

If your appliance fails to operate properly while in use under normal household conditions within the warranty period, you may return the complete appliance and accessories with proof of purchase and date, freight prepaid. For customer service support, call 1-800-798-7398 or visit our website at www.sharkclean.com.

If the appliance is found by **EURO-PRO Operating LLC** to be defective, in **EURO-PRO Operating LLC's** sole discretion, we will repair or replace it free of charge. Proof of purchase date and a check made payable to **EURO-PRO Operating LLC** in the amount of \$19.95 to cover the cost of return shipping and handling must be included.*

Non-durable parts including, without limitation, filters, brushes and electrical parts which normally require replacement are specifically excluded from warranty.

This Limited Warranty is extended to the original purchaser of the unit and excludes all other legal, implied and/or conventional warranties. The responsibility of **EURO-PRO Operating LLC** if any, is limited to the specific obligations expressly assumed by it under the terms of this Limited Warranty. **In no event is EURO-PRO Operating LLC** liable for incidental or consequential damages to anyone of any nature whatsoever. Some states do not permit the exclusion or limitation of incidental or consequential damages, so the above may not apply to you.

This Limited Warranty gives you specific legal rights, and you may also have other rights which vary from state to state or province to province.

***IMPORTANT: Carefully pack item to avoid damage in shipping. Be sure to include proof of purchase date and to attach a tag to item before packing including your name, complete address and phone number with a note giving purchase information, model number and what you believe is the problem with the item. We recommend you insure the package (as damage in shipping is not covered by your warranty). Mark the outside of your package "ATTENTION CUSTOMER SERVICE". We are constantly striving to improve our products, therefore the specifications contained herein are subject to change without notice.**

PRODUCT REGISTRATION

Please visit www.sharkclean.com or call 1-800-798-7398 to register your new Shark® product within ten (10) days of purchase. You will be asked to provide the store name, date of purchase and model number along with your name and address.

The registration will enable us to contact you in the unlikely event of a product safety notification. By registering you acknowledge to have read and understood the instructions for use, and warnings set forth in the accompanying instructions.

Shark®

Copyright © 2013 Euro-Pro Operating LLC

USA: Newton, MA 02459

CANADA: Ville St-Laurent, QC H4S 1A7

Printed in China

Illustrations may differ from actual product.

V2700Z.E.131115.7

Euro-Pro and Shark, are trademarks
of Euro-Pro Operating LLC.

www.sharkclean.com
1-800-798-7398