

# ***Shark***<sup>®</sup>

## ***Rocket***<sup>®</sup>

**ULTRA-LIGHT WITH DUOCLEAN<sup>®</sup>**

### **UV380**

**Series**

---

### **INSTRUCTIONS**



 [sharkclean.com](http://sharkclean.com)

 1-800-798-7398

# THANK YOU

for purchasing the Shark® Rocket® Ultra-Light with DuoClean®



**TIP:** You can find the model number on the rating label which is located below the handle.

**TIP:** You can locate the date code on one of the prongs of the power cord plug.

## REGISTER YOUR PURCHASE

- registeryourshark.com
- 1-800-798-7398
- Scan QR code using mobile device

## RECORD THIS INFORMATION

Model Number: \_\_\_\_\_  
Date Code: \_\_\_\_\_  
Date of Purchase: \_\_\_\_\_  
(Keep receipt)  
Store of Purchase: \_\_\_\_\_

## TECHNICAL SPECIFICATIONS

Voltage: 120V, 60Hz  
Watts: 505W  
Amps: 4.2A

## PLEASE READ CAREFULLY AND KEEP FOR FUTURE REFERENCE.

This Owner's Guide is designed to help you get a complete understanding of your new Shark Rocket Ultra-Light with DuoClean.

If you should have a question, please call the Customer Service line at 1-800-798-7398.

# CONTENTS

<b>Important Safety Instructions</b> .....	<b>3</b>
<b>Assembling Your Vacuum</b> .....	<b>5</b>
<b>Using the Motorized Floor Nozzle</b> .....	<b>6</b>
<b>Using Your Vacuum in Above-Floor Mode</b> .....	<b>7</b>
<b>Storage</b> .....	<b>8</b>
<b>Accessories</b> .....	<b>9</b>
<b>Maintaining Your Vacuum</b> .....	<b>11</b>
Emptying the Dust Cup .....	11
Cleaning the Filters .....	12
Checking for Blockages .....	13
Maintaining the Brushroll .....	14
Maintaining the Soft Roller .....	14
<b>Troubleshooting Guide</b> .....	<b>15</b>
<b>Warranty</b> .....	<b>16</b>

# IMPORTANT SAFETY INSTRUCTIONS

## HOUSEHOLD USE ONLY

To reduce the risk of electric shock, this vacuum cleaner has a polarized plug (one blade is wider than the other). As a safety feature, this plug will fit into a polarized outlet only one way. If the plug does not fit fully into the outlet, reverse the plug. If it still does not fit, contact a qualified electrician. **DO NOT force into outlet or try to modify to fit.**

## **⚠** WARNING

### TO REDUCE THE RISK OF FIRE, ELECTRIC SHOCK OR INJURY:

#### GENERAL WARNINGS

1. Your vacuum cleaner may consist of a motorized nozzle, wand, hose, and/or vacuum pod. This device contains electrical connections, electrical wiring, and moving parts that potentially present risk to the user.
2. Use only identical replacement parts.
3. Carefully observe and follow the instructions provided below to avoid improper use of the appliance. **DO NOT** use the vacuum for any purpose other than those described in this manual.
4. Before use, carefully inspect all parts for any damage. **DO NOT** use if any parts are damaged.
5. The use of an extension cord is **NOT** recommended.
6. This vacuum cleaner contains no serviceable parts.

#### USE WARNINGS

7. **DO NOT** allow the appliance to be used by children. Close supervision is necessary when used near children. This is not a toy.
8. Always turn off the vacuum cleaner before connecting or disconnecting any motorized nozzles or other accessories.
9. **DO NOT** handle plug or vacuum cleaner with wet hands.
10. **DO NOT** use without filters in place.

11. Only use Shark® branded filters and accessories. Failure to do so will also void the warranty.
12. **DO NOT** damage the power cord:
  - a) **DO NOT** pull or carry vacuum cleaner by the cord or use the cord as a handle.
  - b) **DO NOT** unplug by pulling on cord. Grasp the plug, not the cord.
  - c) **DO NOT** run the vacuum cleaner over the power cord, close a door on the cord, pull the cord around sharp corners, or leave the cord near heated surfaces.
13. **DO NOT** put any objects into nozzle or accessory openings. **DO NOT** use with any opening blocked; keep free of dust, lint, hair, and anything that may reduce airflow.
14. **DO NOT** use if nozzle or accessory airflow is restricted. If the air paths or the motorized floor nozzle become blocked, turn the vacuum cleaner off and unplug from electrical outlet. Remove all obstructions before you plug in and turn on the unit again.
15. Keep nozzle and all vacuum openings away from hair, face, fingers, uncovered feet, or loose clothing.
16. **DO NOT** use if vacuum cleaner is not working as it should, or has been dropped, damaged, left outdoors, or dropped into water.

# SAVE THESE INSTRUCTIONS

## READ ALL INSTRUCTIONS BEFORE USE

17. Use extra care when cleaning on stairs.
18. **DO NOT** leave the vacuum cleaner unattended while plugged in.
19. When powered on, keep the vacuum cleaner moving over the carpet surface at all times to avoid damaging the carpet fibers.
20. **DO NOT** place vacuum cleaner on unstable surfaces such as chairs or tables.
21. Your Shark® vacuum may not be designed to stand up on its own. When taking a break from cleaning, you may need to lean it against furniture or a wall, or lay it flat on the floor. Using the vacuum for an application where the unit lacks stability may result in personal injury.
22. **DO NOT** use to pick up:
  - a) Liquids
  - b) Large objects
  - c) Hard or sharp objects (glass, nails, screws, or coins)
  - d) Large quantities of dust (drywall dust, fireplace ash, or embers). **DO NOT** use as an attachment to power tools for dust collection.
  - e) Smoking or burning objects (hot coals, cigarette butts, or matches)
  - f) Flammable or combustible materials (lighter fluid, gasoline, or kerosene)
  - g) Toxic materials (chlorine bleach, ammonia, or drain cleaner)
23. **DO NOT** use in the following areas:
  - a) Poorly lit areas
  - b) Wet or damp surfaces
  - c) Outdoor areas
  - d) Spaces that are enclosed and may contain explosive or toxic fumes or vapors (lighter fluid, gasoline, kerosene, paint, paint thinners, mothproofing substances, or flammable dust)
24. Turn off all controls before plugging in or unplugging the vacuum.
25. Unplug from electrical outlet when not in use and before any maintenance or cleaning.
26. Hand wash with water only. Washing with cleaning chemicals could damage the unit.
27. During cleaning or routine maintenance, **DO NOT** cut anything other than hair, fibers, or string wrapped around the brushroll.
28. Allow all filters to air-dry completely before replacing in the vacuum to prevent liquid from being drawn into electric parts.
29. Make sure the dust cup and all filters are in place after routine maintenance.
30. If provided, secure the power cord around the two cord hooks during storage.

## ASSEMBLING YOUR VACUUM

### STEP 1

Insert the wand into the motorized floor nozzle connector, pressing it in until it clicks into place.

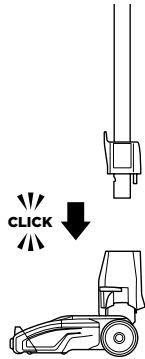

### STEP 2

Insert the handheld vacuum into the top of the wand, pressing it in until it clicks into place.

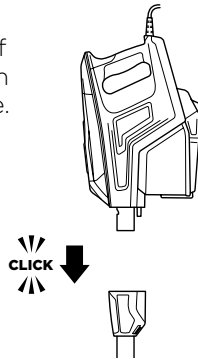

## USING THE MOTORIZED FLOOR NOZZLE

**NOTE:** Before vacuuming your area rugs or carpet, refer to the manufacturer's recommended cleaning instructions.

### WHAT DOES THE BRUSHROLL INDICATOR LIGHT MEAN?

#### Solid Green

The brushrolls are on and working as they should.

#### Solid Red

There is a jam in the brushroll area. Turn your vacuum off and remove the blockage.

#### No Light

The brushrolls are off because the vacuum is off.

**NOTE:** The motorized floor nozzle and handheld vacuum have LED lights that illuminate the floor surface being cleaned. The lights turn on automatically in either speed setting.

**TIP:** You can attach the handheld vacuum directly to the motorized floor nozzle for convenient stair cleaning.

### STEP 1

Plug the unit in and recline the wand.

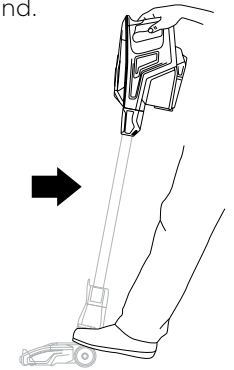

### STEP 2

Slide the power switch to appropriate speed setting (I or II) and start cleaning.

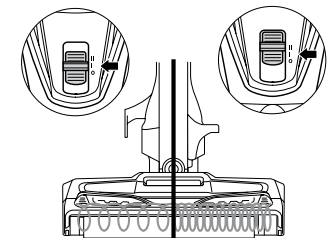

**Bare Floor, Area Rugs (I)** - The brushroll and the Soft Roller both spin together slowly to clean bare floors and area rugs. The Soft Roller traps fine dust and large particles, while the brushroll directs that debris to the suction channel.

**High Pile Carpets (II)** - Both brushrolls spin faster, working together to pick up debris below the surface of your carpets.

**NOTE:** For deep cleaning per ASTM F 608 (embedded dirt in carpets) please set to High Pile Carpets (II).

## USING YOUR VACUUM IN ABOVE-FLOOR MODE

### WAND

#### STEP 1

Stand the vacuum upright. Step on the foot pedal and pull the wand up to disconnect it from the motorized floor nozzle.

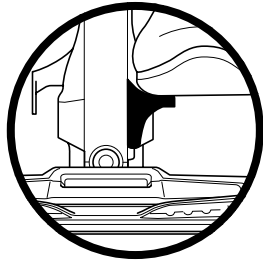

#### STEP 2

Attach desired cleaning accessory.



### HANDHELD

#### STEP 1

Press the Wand Release button on the top of the wand to disconnect it from the handheld vacuum.

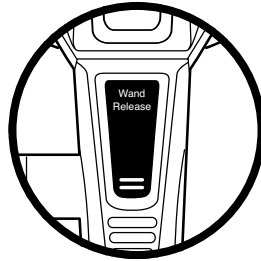

#### STEP 2

Attach desired cleaning accessory.



## STORAGE

### OPTION 1

Press the Wand Release button on the top of the wand to release the handheld vacuum. Align the catch on the bottom of the handheld vacuum with the storage hook on the wand. Slide handheld vacuum down so that it hangs from the storage hook. Wrap the cord around the two cord hooks.

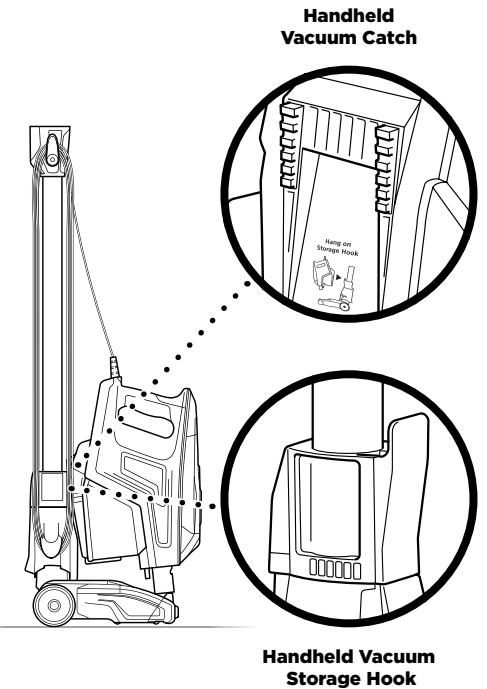

## ACCESSORIES

There are a variety of accessories that are compatible with this vacuum series.

Your Quick Start Guide shows the accessories that are included with your model.

**To purchase additional accessories, go to [sharkclean.com](http://sharkclean.com)**

- A 5.5" Crevice Tool**  
Access corners, baseboards, tight spaces, and ceilings for versatile cleaning.
- B 12" Crevice Tool**  
Clean in tight spaces or reach baseboards and ceilings with this slim crevice tool.
- C Duster Crevice Tool**  
Two cleaning tools in one. The crevice tool gives you extended cleaning reach for small spaces, while the dusting brush cleans a multitude of surfaces.
- D Dusting Brush**  
Multiple positions for cleaning shelves, blinds, walls, ceiling fans, and much more. Adjust the angle of the brush to fit the surface you're cleaning.
- E Pet/Upholstery Tool**  
Perfect for grabbing pet hair and lint from furniture and other upholstered surfaces.
- F Pet Multi-Tool**  
A single convertible tool for cleaning tough pet messes two ways: first, a stiff bristle brush for cleaning stuck-on debris. Then take off the bristles to reveal an upholstery tool for removing stubborn pet hair.
- G Under-Appliance Wand**  
Clean under and behind hard-to-move appliances. Flip the extension piece over to clean the underside of appliances.

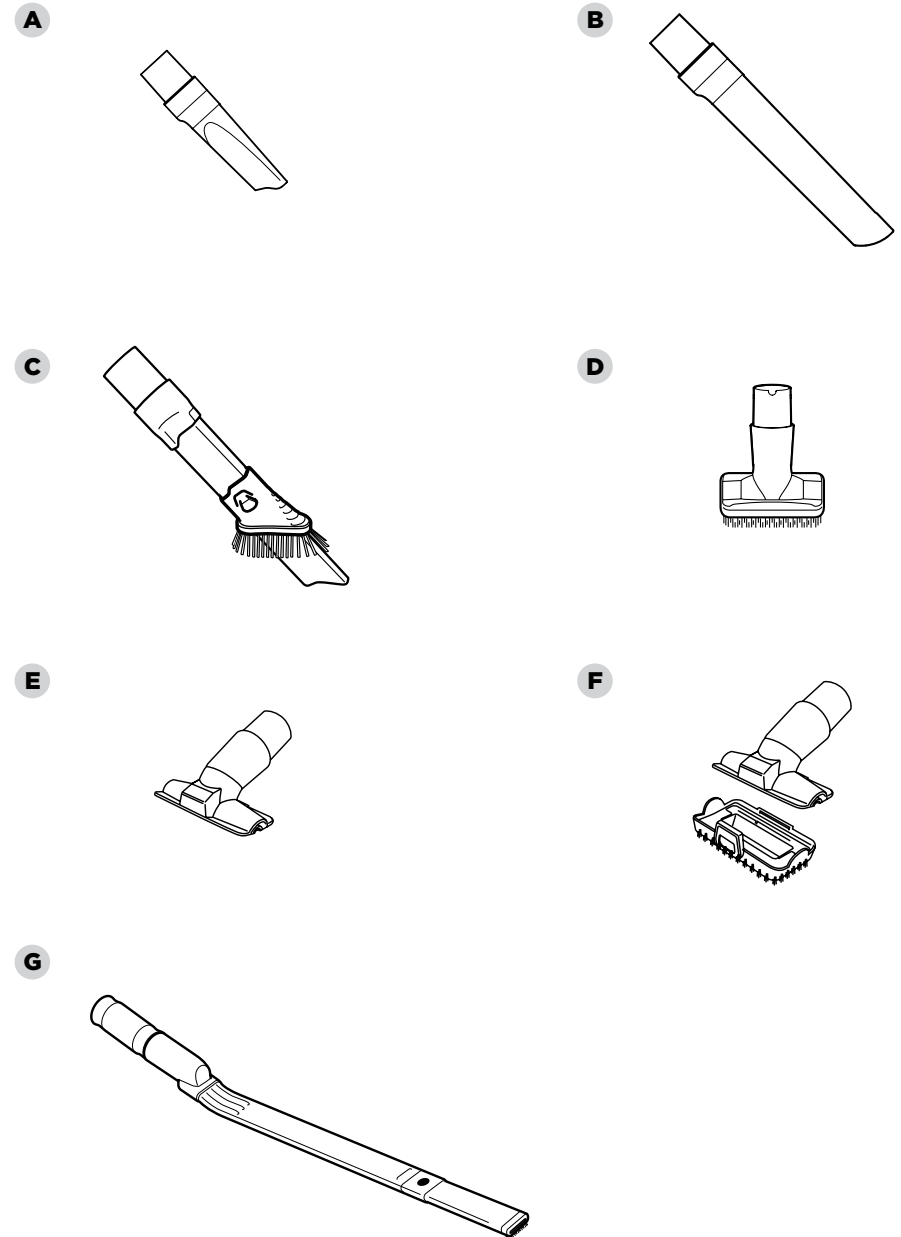

# MAINTAINING YOUR VACUUM

**IMPORTANT:** Clean the dust screen inside the dust cup as required.

**NOTE:** Empty dust cup when debris reaches the MAX fill line.

## EMPTYING THE DUST CUP

- 1 Press the Wand Release button on the top of the wand to disconnect the handheld vacuum from the wand.

**OR**

To remove the dust cup from the handheld vacuum, squeeze the two Dust Cup Release buttons on both sides of the base at the same time, then pull out the dust cup.

- 2 Hold dust cup over a trash bin and press the Empty button on the front of the dust cup. The bottom lid will open, allowing the debris to fall out.
- 3 Once dust cup is empty, close the bottom lid and insert dust cup back into handheld vacuum until it clicks into place.

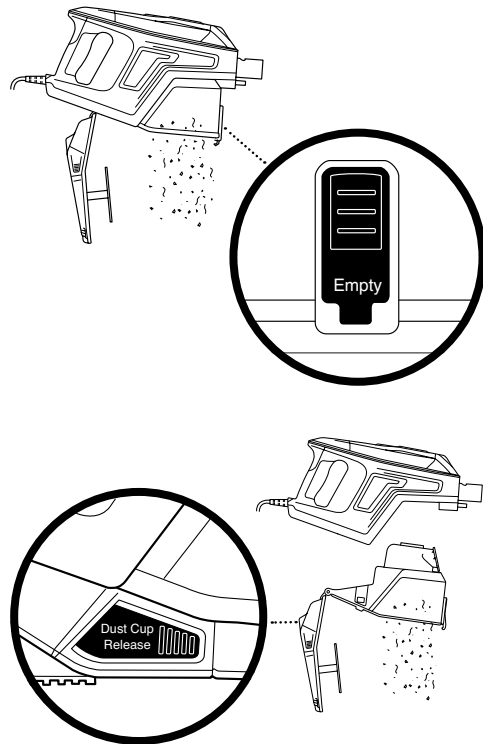

## RECOMMENDED FILTER CLEANING SCHEDULE:

**Pre-Motor Filter Kit**  
(Foam & Felt)  
XPMFK320  
Clean once a month.

**Post-Motor Filter**  
XPSTFH380  
Clean once a year.

## CLEANING THE FILTERS

- 1 **Pre-Motor (foam and felt):**  
Lift the latch on the top of the handheld vacuum to open the filter cover. Take out filters and tap loose dirt off them. If more cleaning is needed, rinse filters with water only and let them air-dry completely. To reinstall them, insert the felt filter first, place the foam filter on top of it, and close the filter cover.
- 2 **Post-Motor:**  
Access the Post-Motor filter under the handle. Remove and rinse the filter with water.

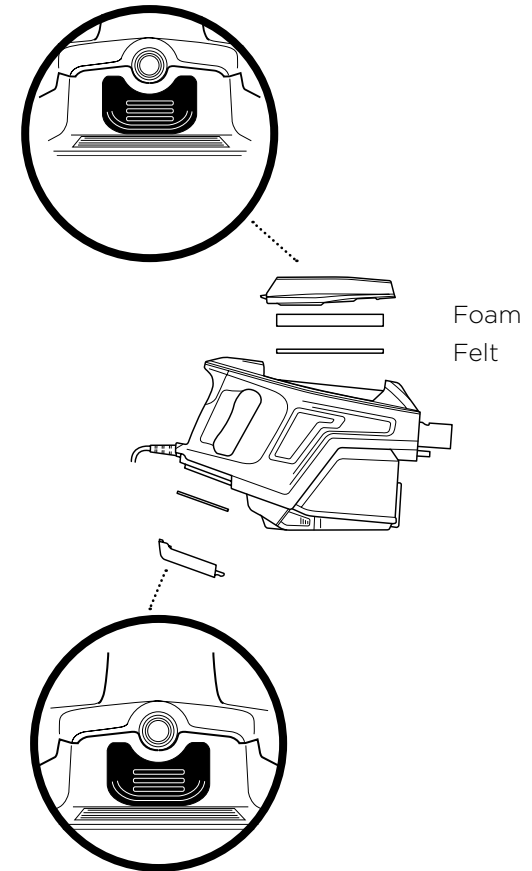

## MAINTAINING YOUR VACUUM - Continued

**TIP:** Ensure the brushroll garage is completely sealed and closed before using.

**NOTE:** Heavy usage over time may require minimal upkeep in order to maintain your vacuum's appearance.

### CHECKING FOR BLOCKAGES

- 1 Remove the wand from the handheld vacuum and check all dust cup intake openings.
- 2 Remove the floor nozzle from the wand and check the wand for blockages.
- 3 Tilt neck of floor nozzle back to straighten the airway. Remove blockages.

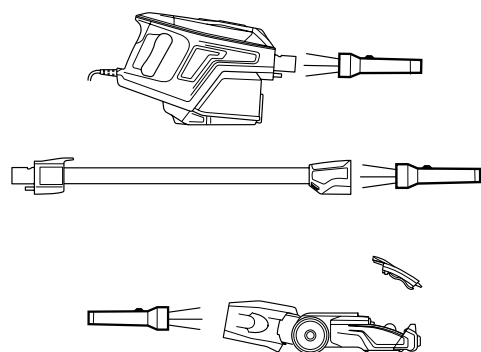

### MAINTAINING THE BRUSHROLL

- 1 Press down on the two buttons on the floor nozzle to pop up the brushroll garage lid.

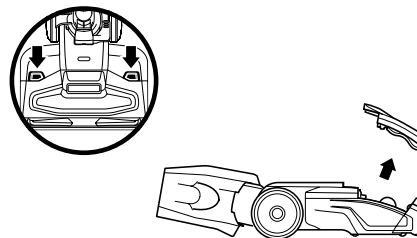

- 2 Lift the brushroll out by the tab on the left side. Use a pair of scissors to carefully remove any string, hair or debris that may be wrapped around the brushroll.

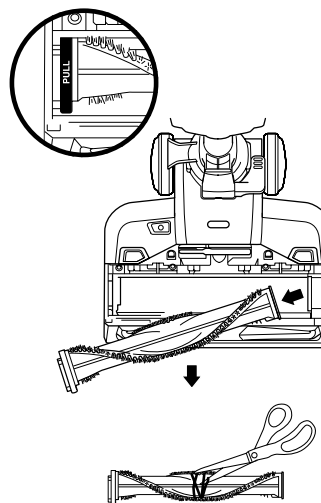

- 3 To reinstall the brushroll, return it to the brushroll garage. Press down on the brushroll garage lid until it clicks into place.

### MAINTAINING THE SOFT ROLLER

- 1 Slide the Soft Roller access button up to remove the Soft Roller.

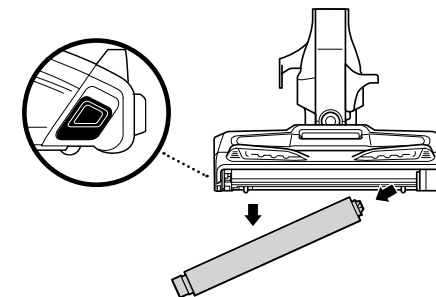

- 2 Remove any string, carpet fibers or hair that may be wrapped around the Soft Roller. You can also tap loose debris off the Soft Roller, or wipe it clean with a dry towel. If you see any fibers or hair buildup in the teeth behind the Soft Roller, take a dry towel and wipe it away. Wash the Soft Roller as needed. Use only water, and let air-dry completely for at least 24 hours.

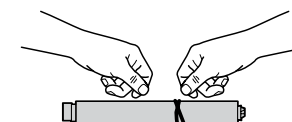

- 3 To reinstall the Soft Roller, press until it clicks into place.

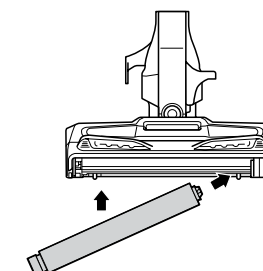



### **Vacuum is not picking up debris. No suction or light suction. (Refer to Maintenance section for more information.)**

- Check filters to see if they need cleaning. Follow instructions for rinsing and completely air-drying the filters before reinserting in the vacuum.
- Dust cup may be full; empty dust cup.
- Check floor nozzle for blockages; clear blockages if required.
- Remove any string, carpet fibers, or hair that may be wrapped around the brushroll and Soft Roller or trapped behind the Soft Roller.

### **Vacuum lifts area rugs.**

- Suction is powerful. Take care when vacuuming area rugs or rugs with delicately sewn edges.
- Turn off the unit to disengage the brushroll then slide the Power switch to Setting I (Bare Floor, Area Rugs) to restart.

### **Brushroll/Soft Roller does not spin.**

- If Brushroll Indicator Light on the floor nozzle turns red, the brushroll and/or Soft Roller have stopped spinning. Immediately turn off and unplug vacuum and remove blockage before reconnecting and turning vacuum back on.
- If Brushroll Indicator Light on the floor nozzle is green, the blockage has been successfully cleared. If the light is still red, please contact Customer Service at 1-800-798-7398.

### **Vacuum turns off on its own, or indicator light flashes red.**

This vacuum is equipped with a motor-protective thermostat so the vacuum will shut off if it overheats. Should this occur, perform the following steps to restart the motor-protective thermostat:

1. Turn vacuum off and unplug it.
2. Empty dust cup and clean filters (see Maintenance section).
3. Check for blockages in hose, accessories, and inlet openings.
4. Allow unit to cool for a minimum of 45 minutes.
5. Plug in vacuum and turn it on.

Note: If vacuum still does not start, contact Customer Service at 1-800-798-7398.

The 5-Year Limited Warranty applies to purchases made from authorized retailers of **SharkNinja Operating LLC**. Warranty coverage applies to the original owner and to the original product only and is not transferable.

SharkNinja warrants that the unit shall be free from defects in material and workmanship for a period of 5 years from the date of purchase when it is used under normal household conditions and maintained according to the requirements outlined in this instruction manual, subject to the following conditions and exclusions.

### **What is covered in my warranty?**

1. The original unit and/or non-wearable components deemed defective, in SharkNinja's sole discretion, will be repaired or replaced for up to 5 years from the original purchase date.
2. In the rare event that a replacement unit is issued, the warranty coverage ends six months following the receipt date of the replacement unit or the remainder of the existing warranty, whichever is greater. If the unit is replaced, SharkNinja reserves the right to replace the unit with one of equal or greater value.

### **What is not covered in my warranty?**

Our Customer Service/Product Specialists are available to provide all the warranty service options available to you, including the possibility of upgrading to our VIP Warranty Service Options for select product categories.

1. Normal wear and tear of wearable parts such as foam filters, HEPA filters, pads etc., which require regular maintenance and/or replacement to ensure the proper functioning of your unit are not covered by this warranty.
2. Any unit that has been tampered with or used for commercial purposes.
3. SharkNinja will cover the cost for the customer to send in the unit to us for repair or replacement. A fee of \$19.95 for return shipping costs will be charged at the time of return shipment of the repaired or replacement unit.
4. Damage caused by misuse, abuse, or negligent handling, or damage due to mishandling in transit.
5. Consequential and incidental damages.
6. Defects caused by or resulting from damages from shipping or from repairs, service or alteration to the product or any of its parts which have been performed by a repair person not authorized by SharkNinja.
7. Products purchased, used or operated outside of North America.

### **Problems with your unit/How to get service**

If your appliance fails to operate properly while in use under normal household conditions within the warranty period, visit [sharkclean.com](http://sharkclean.com) for product care/maintenance self-help. Our Customer Service and product specialists are also available at 1-800-798-7398 to assist with product support and warranty service options.

### **How to initiate a warranty claim**

You can call 1-800-798-7398 to have a Customer Service specialist assist you. Please note you must call 1-800-798-7398 to initiate a warranty claim. Return and Packing Instruction information will be provided at that time.

For Customer Service hours, visit [sharkclean.com](http://sharkclean.com).

Replacement parts are available for purchase at [sharkclean.com](http://sharkclean.com). For more information on which parts are classified as wearable or non-wearable, please visit [sharkclean.com/warranty](http://sharkclean.com/warranty).

This warranty gives you specific legal rights, and you also may have other rights that vary from state to state.

Some states do not permit the exclusion or limitation of incidental or consequential damages, so the above may not apply to you.





**SharkNinja Operating LLC**  
**US: Needham, MA 02494**  
**CAN: Ville St-Laurent, QC H4S 1A7**  
**1-800-798-7398**  
**sharkclean.com**

Illustrations may differ from actual product. We are constantly striving to improve our products; therefore the specifications contained herein are subject to change without notice.

DUOCLEAN, ROCKET, and SHARK are registered trademarks of SharkNinja Operating LLC.

For SharkNinja U.S. Patent information, visit [sharkninja.com/uspatents](http://sharkninja.com/uspatents)

© 2018 SharkNinja Operating LLC  
UV380Series\_IB\_MP\_Mv7  
PRINTED IN CHINA



**@sharkcleaning**