

# ***Shark***<sup>®</sup>

## **ROTATOR**<sup>®</sup>

### **Professional**

**NV400**

**Series**

**INSTRUCTIONS**



 [sharkclean.com](http://sharkclean.com)

 1-800-798-7398

# THANK YOU

for purchasing the Shark® Rotator® Professional



Scan QR code using mobile device.

**TIP:** You can find the model number on the rating label located on the back of your unit.

**TIP:** You can locate the date code on one of the prongs of the power cord plug.

## REGISTER YOUR PURCHASE

 sharkclean.com

 1-800-798-7398

## RECORD THIS INFORMATION

Model Number: \_\_\_\_\_

Date Code: \_\_\_\_\_

Date of Purchase (Keep receipt): \_\_\_\_\_

Store of Purchase: \_\_\_\_\_

## TECHNICAL SPECIFICATIONS

Voltage: 120V, 60Hz

Watts: 1200W

Amps: 10A

## PLEASE READ CAREFULLY AND KEEP FOR FUTURE REFERENCE.

This Owner's Guide is designed to help you get a complete understanding of your new Shark Rotator Professional.

If you have any questions, please call the Customer Service line at 1-800-798-7398.

# CONTENTS

<b>Important Safety Instructions</b> .....	<b>3</b>
<b>Getting to Know Your Shark® Rotator® Professional</b> .....	<b>5</b>
<b>Assembling Your Vacuum</b> .....	<b>7</b>
<b>Using Your Vacuum in Upright Mode</b> .....	<b>9</b>
What Does the Brushroll Indicator Light Mean? .....	9
<b>Using Your Vacuum in Above-Floor Mode</b> .....	<b>11</b>
The Benefits of Suction Control .....	11
<b>Compatible Accessories</b> .....	<b>13</b>
<b>Maintenance</b> .....	<b>15</b>
Emptying the Dust Cup .....	15
Cleaning the Filters .....	16
<b>Checking for Blockages</b> .....	<b>17</b>
Bottom of Floor Nozzle .....	17
Hose Cuff at Base of Pod .....	18
<b>Troubleshooting Guide</b> .....	<b>19</b>
<b>Warranty</b> .....	<b>20</b>

# IMPORTANT SAFETY INSTRUCTIONS

## HOUSEHOLD USE ONLY

**To reduce the risk of electric shock, this vacuum cleaner has a polarized plug (one blade is wider than the other). As a safety feature, this plug will fit into a polarized outlet only one way. If the plug does not fit fully into the outlet, reverse the plug. If it still does not fit, contact a qualified electrician. DO NOT force into outlet or try to modify to fit.**

## **⚠ WARNING**

### **TO REDUCE THE RISK OF FIRE, ELECTRIC SHOCK OR INJURY:**

#### **GENERAL WARNINGS**

1. Your vacuum cleaner may consist of a motorized nozzle, wand, hose, and/or vacuum pod. This device contains electrical connections, electrical wiring, and moving parts that potentially present risk to the user.
2. Use only identical replacement parts.
3. Carefully observe and follow the instructions provided below to avoid improper use of the appliance. **DO NOT** use the vacuum for any purpose other than those described in this manual.
4. Before use, carefully inspect all parts for any damage. **DO NOT** use if any parts are damaged.
5. The use of an extension cord is **NOT** recommended.
6. This vacuum cleaner contains no serviceable parts.

#### **USE WARNINGS**

7. **DO NOT** allow the appliance to be used by children. Close supervision is necessary when used near children. This is not a toy.
8. Always turn off the vacuum cleaner before connecting or disconnecting any motorized nozzles or other accessories.
9. **DO NOT** handle plug or vacuum cleaner with wet hands.
10. **DO NOT** use without filters in place.

11. Only use Shark® branded filters and accessories. Failure to do so will also void the warranty.
12. **DO NOT** damage the power cord:
  - a) **DO NOT** pull or carry vacuum cleaner by the cord or use the cord as a handle.
  - b) **DO NOT** unplug by pulling on cord. Grasp the plug, not the cord.
  - c) **DO NOT** run the vacuum cleaner over the power cord, close a door on the cord, pull the cord around sharp corners, or leave the cord near heated surfaces.
13. **DO NOT** put any objects into nozzle or accessory openings. **DO NOT** use with any opening blocked; keep free of dust, lint, hair, and anything that may reduce airflow.
14. **DO NOT** use if nozzle or accessory airflow is restricted. If the air paths or the motorized floor nozzle become blocked, turn the vacuum cleaner off and unplug from electrical outlet. Remove all obstructions before you plug in and turn on the unit again.
15. Keep nozzle and all vacuum openings away from hair, face, fingers, uncovered feet, or loose clothing.
16. **DO NOT** use if vacuum cleaner is not working as it should, or has been dropped, damaged, left outdoors, or dropped into water.

# SAVE THESE INSTRUCTIONS

## READ ALL INSTRUCTIONS BEFORE USE

17. Use extra care when cleaning on stairs.
18. **DO NOT** leave the vacuum cleaner unattended while plugged in.
19. When powered on, keep the vacuum cleaner moving over the carpet surface at all times to avoid damaging the carpet fibers.
20. **DO NOT** place vacuum cleaner on unstable surfaces such as chairs or tables.
21. Your Shark® Vacuum may not be designed to stand up on its own. When taking a break from cleaning, you may need to lean it against furniture or a wall, or lay it flat on the floor. Using the vacuum for an application where the unit lacks stability may result in personal injury.
22. **DO NOT** use to pick up:
  - a) Liquids
  - b) Large objects
  - c) Hard or sharp objects (glass, nails, screws, or coins)
  - d) Large quantities of dust (drywall dust, fireplace ash, or embers). **DO NOT** use as an attachment to power tools for dust collection.
  - e) Smoking or burning objects (hot coals, cigarette butts, or matches)
  - f) Flammable or combustible materials (lighter fluid, gasoline, or kerosene)
  - g) Toxic materials (chlorine bleach, ammonia, or drain cleaner)
23. **DO NOT** use in the following areas:
  - a) Poorly lit areas
  - b) Wet or damp surfaces
  - c) Outdoor areas
  - d) Spaces that are enclosed and may contain explosive or toxic fumes or vapors (lighter fluid, gasoline, kerosene, paint, paint thinners, mothproofing substances, or flammable dust)
24. Turn off all controls before plugging in or unplugging the vacuum.
25. Unplug from electrical outlet when not in use and before any maintenance or cleaning.
26. Hand wash with water only. Washing with cleaning chemicals could damage the unit.
27. During cleaning or routine maintenance, **DO NOT** cut anything other than hair, fibers, or string wrapped around the brushroll.
28. Allow all filters to air-dry completely before replacing in the vacuum to prevent liquid from being drawn into electric parts.
29. Make sure the dust cup and all filters are in place after routine maintenance.
30. If provided, secure the power cord around the two cord hooks during storage.

# GETTING TO KNOW YOUR SHARK® ROTATOR® PROFESSIONAL

## WELCOME!

Congratulations on your purchase. Use this instruction manual to learn about your new vacuum's great features. From assembly to use to maintenance, you will find it all in here.

### MAIN UNIT

- A** Brushroll On/Off Button
- B** Power Button
- C** Hose
- D** Hose Clip
- E** Hose Cradle
- F** Extension Wand
- G** Upper Cord Hook
- H** Lower Cord Hook
- I** Motorized Floor Nozzle
- J** Brushroll Indicator Light
- K** Headlights
- L** Dust Cup Release Button
- M** Handle

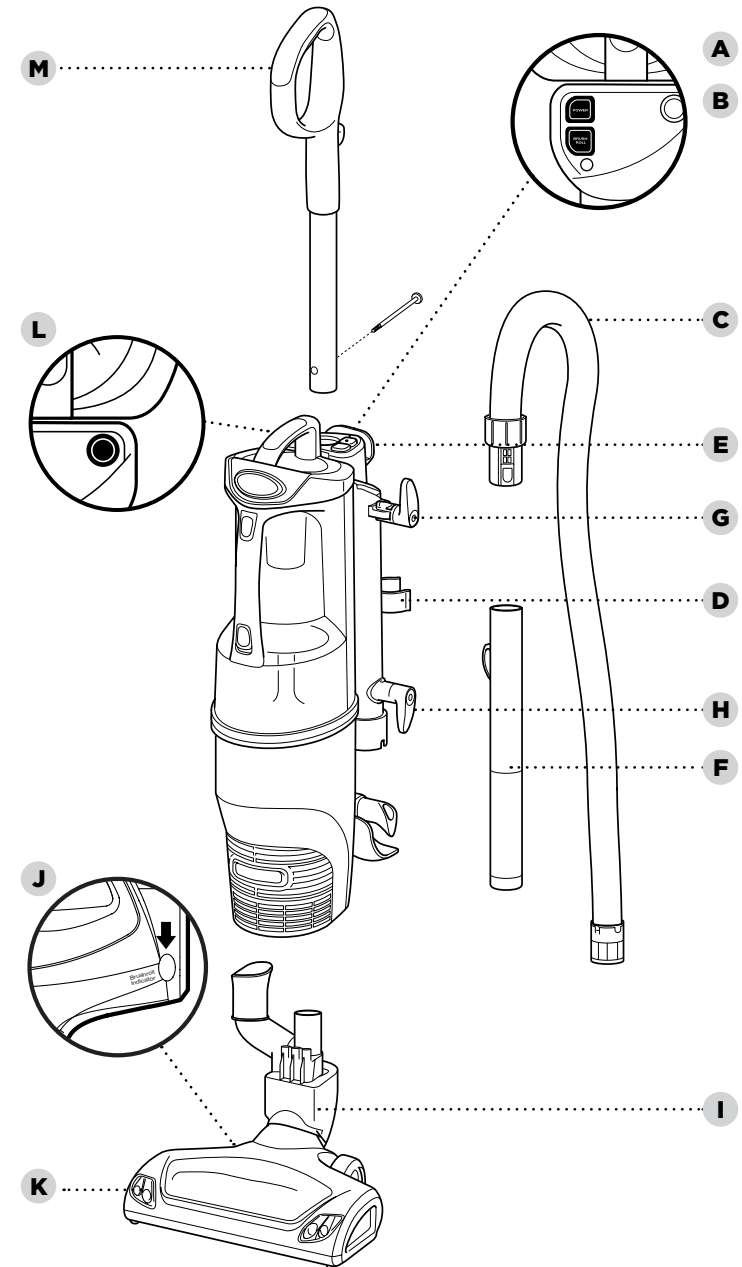

# ASSEMBLING YOUR VACUUM

**TIP:** For quick cord access, rotate upper hook down and remove cord.

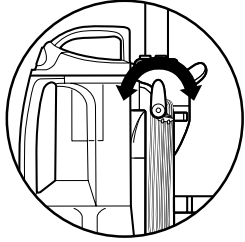

**TIP:** To store your vacuum, wrap cord around cord hooks.

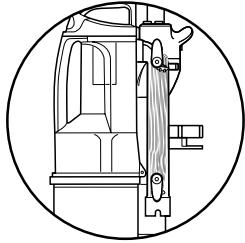

**NOTE:** Use cord clip located on the back of wand to hold cord in place while vacuuming.

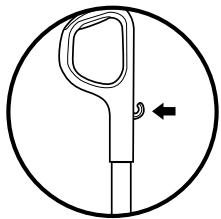

## STEP 1

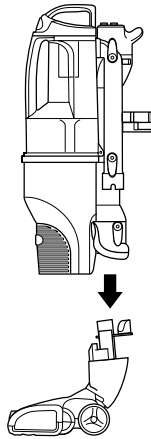

**1** Place the vacuum pod onto floor nozzle.

## STEP 2

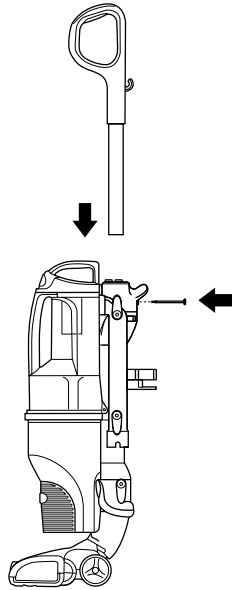

**2** Slide handle into pod and secure with provided bolt.

## STEP 3

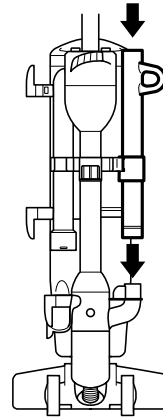

**3** Insert extension wand into tool caddy and lower coupling.

## STEP 4

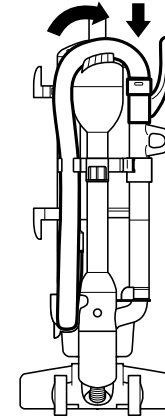

**4** Insert hose into lower clip and set it into cradle at top of pod. Attach hose to top of wand.

## STEP 5

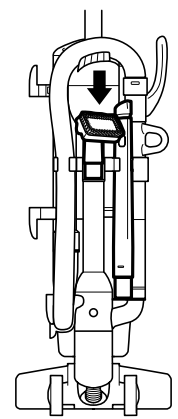

**5** Insert tools into accessory clips.

# USING YOUR VACUUM IN UPRIGHT MODE

## WHAT DOES THE BRUSHROLL INDICATOR LIGHT MEAN?

### Solid Green

The brushroll is on and working as it should.

### Solid Red

There is a jam in the brushroll area. Turn your vacuum off and remove the blockage.

### No Light

The brushroll is off. To turn it on, press the BRUSHROLL button. The light should turn green, and the brushroll should spin.

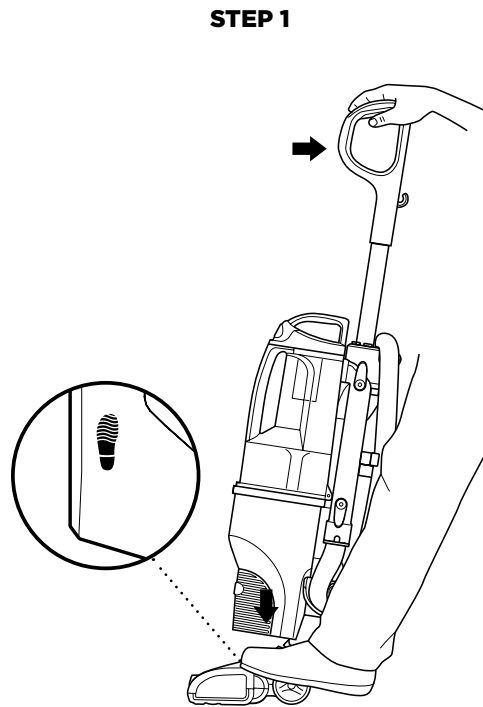
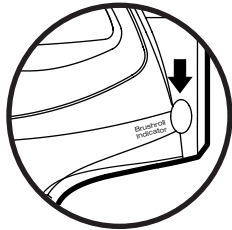

- 1 Plug power cord into outlet. Place foot on floor nozzle and tilt handle back.

## STEP 2

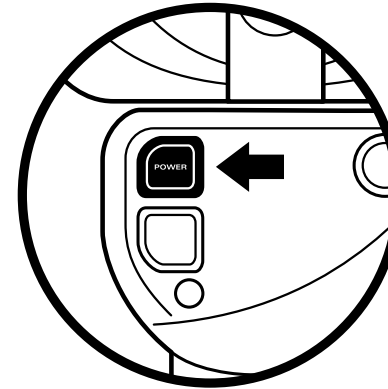

- 2 Press POWER to clean hard floor surfaces, area rugs, or above-floor areas. The brushroll will not spin in this mode.

## STEP 3

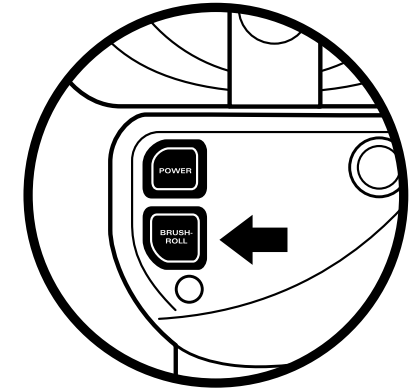

- 3 Press POWER and BRUSHROLL to clean carpets. The BRUSHROLL button will illuminate green. The brushroll will spin only when the handle is reclined and the Brushroll Indicator Light is green.

**NOTE:** For deep cleaning per ASTM F 608 (embedded dirt in carpets) please ensure brushroll is on and slide back the suction control button for maximum suction.

# USING YOUR VACUUM IN ABOVE-FLOOR MODE

## THE BENEFITS OF SUCTION CONTROL

Suction Control is a way for you to adjust suction power when you are using different tools or vacuuming different surfaces. For example, if you are feeling resistance while vacuuming thick carpet or upholstery, slide the suction control button forward to reduce suction and allow the vacuum to move with less resistance.

### STEP 1

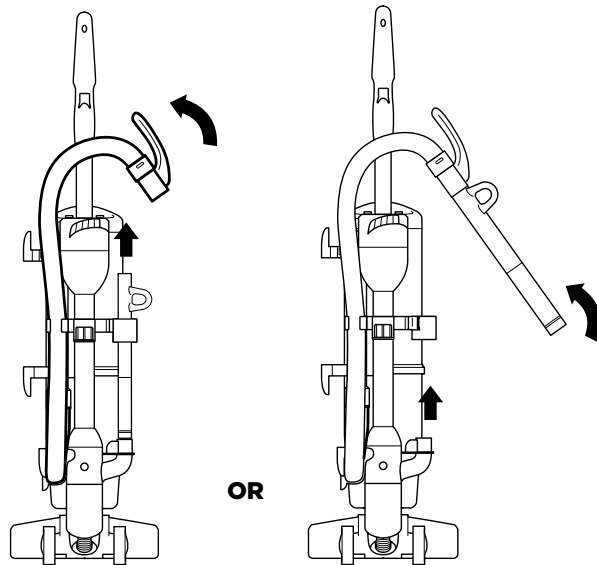

OR

**1** Remove hose from extension wand when you need to clean within short reach.

**OR** Lift out hose with extension wand attached when you need to clean with a longer reach.

### STEP 2

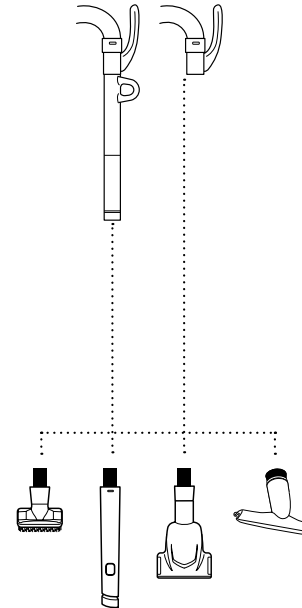

**2** Attach desired cleaning accessory.

### STEP 3

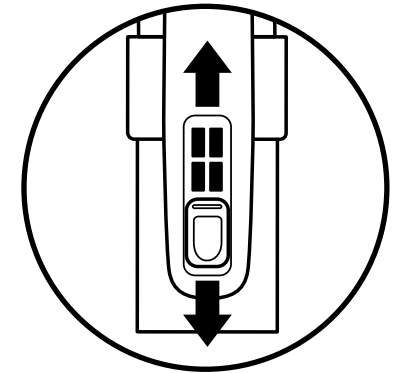

**3** The suction control slider is located at the end of the hose. Slide the button forward to minimize suction. Slide the button back for maximum suction.

## COMPATIBLE ACCESSORIES

There are a variety of accessories that are compatible with this vacuum series.

The top flap of your box shows the select accessories that are included with your model.

**To purchase additional accessories, go to [sharkclean.com](http://sharkclean.com)**

### **A Crevice Tool**

Gives you extended cleaning reach for small spaces.

### **C Dusting Brush**

Cleans hard surfaces and upholstery.

### **E Wide Upholstery Tool**

Remove pet hair and dust from curtains and other delicate fabrics and upholstery.

### **B Pet Power Brush**

Designed for removal of pet hair and ground-in dirt from carpeted stairs and upholstery.

### **D Multi-Angle Dusting Brush**

3-position soft dusting brush cleans shelves, walls, furniture, ceiling fans, lights, and more.

**A**

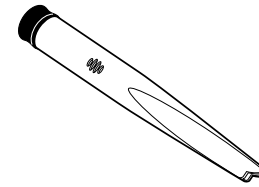

**B**

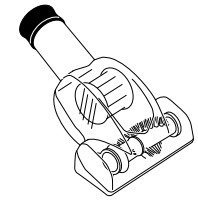

**C**

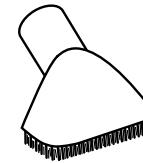

**D**



**E**

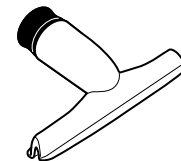



# MAINTENANCE

To keep your vacuum's suction power optimal, follow these instructions. Make sure unit is off and cord is unplugged.

★ **IMPORTANT: DO NOT** use soap when cleaning the filters.

## RECOMMENDED FILTER CLEANING SCHEDULE:

### Pre-Motor Filter Kit

(Foam & Felt)  
XFF400  
Clean every 3 months.

### Post-Motor Filter

(HEPA)  
XHF400  
Clean once a year.

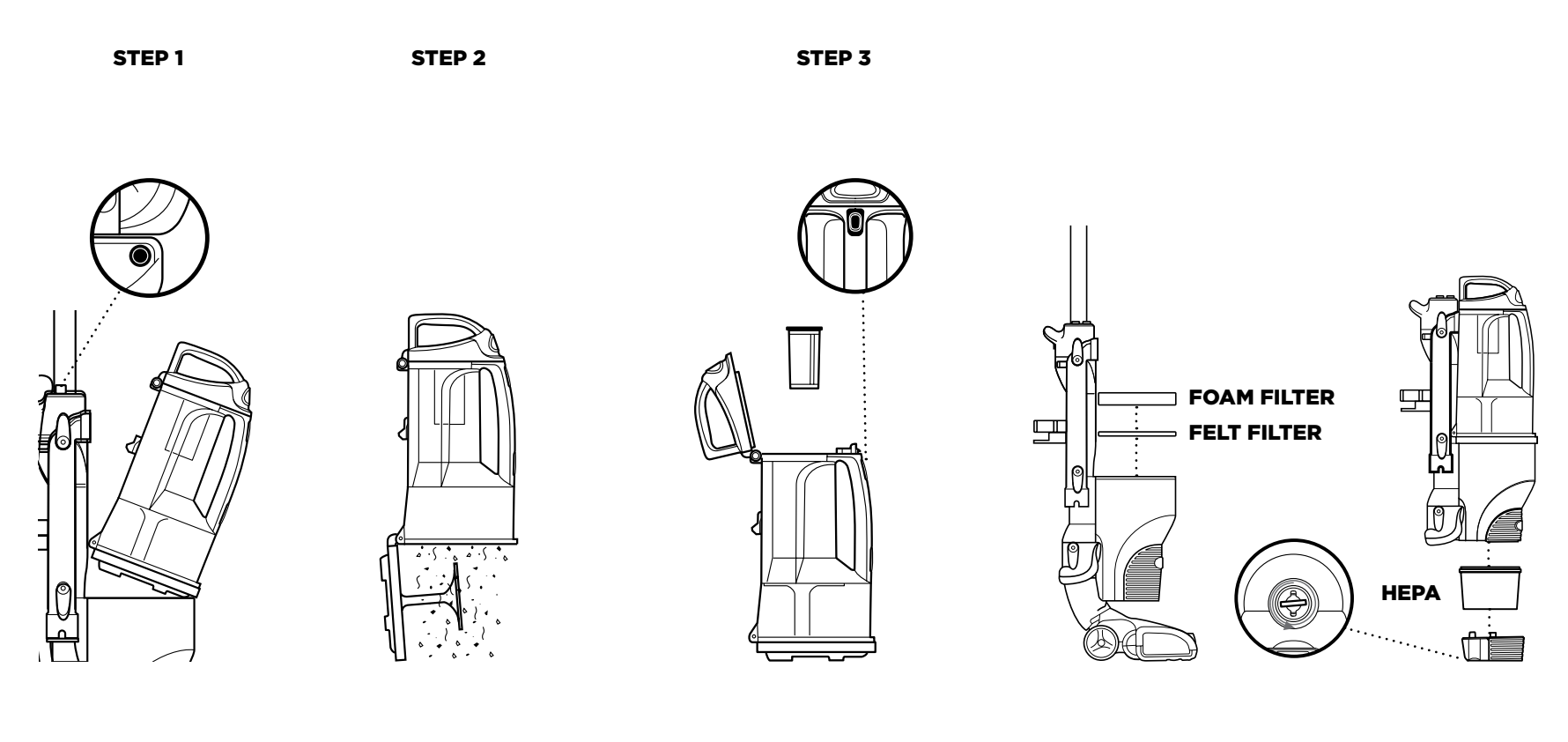

## EMPTYING THE DUST CUP

- 1 Press the Dust Cup Release button and lift dust cup off the vacuum.
- 2 Hold dust cup over a trash bin and press the bottom Dust Cup Release latch.

- 3 Press top Dust Cup Release latch to access dust screen and remove built-up debris as required.

## CLEANING THE FILTERS

- 1 **Pre-Motor (foam and felt):** With the dust cup removed, take out and rinse the foam and felt filters with water. Let filters air-dry completely before reinstalling them. Tap loose dirt off filters between washes as needed.
- 2 **Post-Motor (HEPA):** Remove the floor nozzle by pressing the red nozzle-release button on the back of vacuum. Rotate dial on bottom of pod counterclockwise to release filter frame. Remove and rinse the post-motor filter. Let filter air-dry completely before reinstalling.

# CHECKING FOR BLOCKAGES

## STEP 1

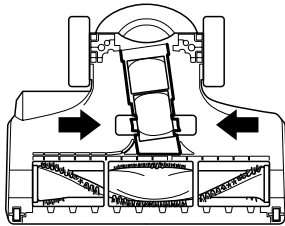

## STEP 2

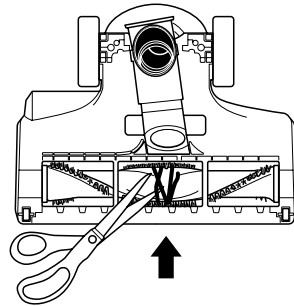

### BOTTOM OF FLOOR NOZZLE

- 1 Squeeze tabs together and pull up to expose the airway.
- 2 Remove any string, hair, or debris that may be wrapped around the brushroll.

## STEP 1

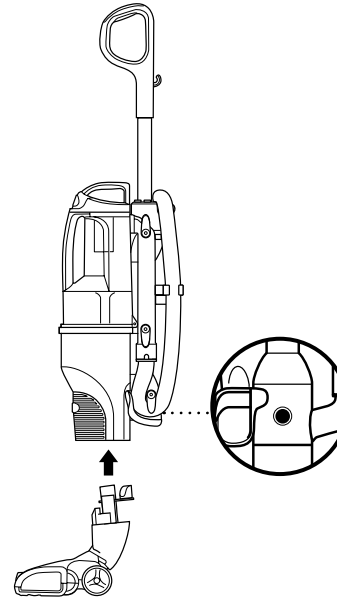

## STEP 2

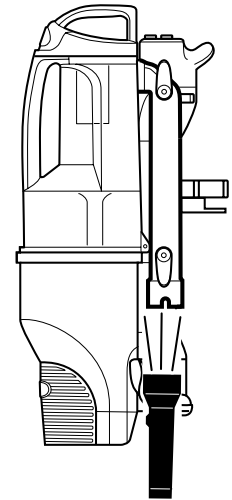

### HOSE CUFF AT BASE OF POD

- 1 Remove floor nozzle and hose.
- 2 Shine a flashlight up from the bottom to check for blockages. Remove dust cup and check all intake openings.

**⚠ WARNING: To reduce the risk of shock and unintended operation, turn power off and unplug unit before servicing.**

**Vacuum is not picking up debris. No suction or light suction.**  
(Refer to Maintenance section for more information.)

- Check filters to see if they need cleaning. Follow instructions for rinsing and drying the filters before reinserting in the vacuum.
- Dust cup may be full; empty dust cup.
- Check hose, hose connections, nozzle, and accessories for blockages; clear blockages if required.
- Remove any string, carpet fibers, or hair that may be wrapped around the brushroll.

**Vacuum lifts area rugs.**

- Turn off unit to disengage the brushroll. Ensure brushroll is turned off and restart with the POWER button for suction-only cleaning.
- Suction is powerful. Take care when vacuuming area rugs or rugs with delicately sewn edges.
- To minimize suction, refer to Suction Control section for more information.

**Brushroll does not spin.**

- If Brushroll Indicator Light on the floor nozzle turns red, the brushroll has stopped spinning. Immediately turn off and unplug vacuum, disconnect the nozzle, and remove blockage before reconnecting and turning vacuum back on.
- With the power on, recline the handle, which will automatically turn on the brushroll.
- Ensure that the BRUSHROLL button is on.

**Vacuum turns off on its own or indicator light flashes red.**

- This vacuum is equipped with a motor-protective thermostat. If your vacuum overheats, the thermostat will automatically turn the suction motor off. Perform the following steps to restart the thermostat:
  1. Turn vacuum off and unplug it.
  2. Empty dust cup and clean filters (see Maintenance section).
  3. Check for blockages in hose, accessories, and inlet openings.
  4. Allow unit to cool for a minimum of 45 minutes.
  5. Plug in vacuum and turn it on.
  6. Restart the unit using either the POWER or BRUSHROLL buttons.

Note: If vacuum still does not start, contact Customer Service at 1-800-798-7398.

The 5-Year Limited Warranty applies to purchases made from authorized retailers of **SharkNinja Operating LLC**. Warranty coverage applies to the original owner and to the original product only and is not transferable.

SharkNinja warrants that the unit shall be free from defects in material and workmanship for a period of 5 years from the date of purchase when it is used under normal household conditions and maintained according to the requirements outlined in this instruction manual, subject to the following conditions and exclusions.

**What is covered in my warranty?**

1. The original unit and/or non-wearable components deemed defective, in SharkNinja's sole discretion, will be repaired or replaced for up to 5 years from the original purchase date.
2. In the rare event that a replacement unit is issued, the warranty coverage ends six months following the receipt date of the replacement unit or the remainder of the existing warranty, whichever is greater. If the unit is replaced, SharkNinja reserves the right to replace the unit with one of equal or greater value.

**What is not covered in my warranty?**

Our Customer Service/Product Specialists are available to provide all the warranty service options available to you, including the possibility of upgrading to our VIP Warranty Service Options for select product categories.

1. Normal wear and tear of wearable parts such as foam filters, HEPA filters, pads etc., which require regular maintenance and/or replacement to ensure the proper functioning of your unit, are not covered by this warranty.
2. Any unit that has been tampered with or used for commercial purposes.
3. SharkNinja will cover the cost for the customer to send in the unit to us for repair or replacement. A fee of \$19.95 for return shipping costs will be charged at the time of return shipment of the repaired or replacement unit.
4. Damage caused by misuse, abuse, or negligent handling, or damage due to mishandling in transit.
5. Consequential and incidental damages.
6. Defects caused by or resulting from damages from shipping or from repairs, service, or alteration to the product or any of its parts that have been performed by a repair person not authorized by SharkNinja.
7. Products purchased, used, or operated outside of North America.

**Problems with your unit/How to get service**

If your appliance fails to operate properly while in use under normal household conditions within the warranty period, visit [sharkclean.com](http://sharkclean.com) for product care/maintenance self-help. Our Customer Service and product specialists are also available at 1-800-798-7398 to assist with product support and warranty service options.

**How to initiate a warranty claim**

You can call 1-800-798-7398 to have a Customer Service specialist assist you. Please note you must call 1-800-798-7398 to initiate a warranty claim. Return and Packing Instruction information will be provided at that time.

For Customer Service hours, visit [sharkclean.com](http://sharkclean.com)

Replacement parts are available for purchase at [sharkclean.com](http://sharkclean.com). For more information on which parts are classified as wearable and non-wearable, please visit [sharkclean.com/warranty](http://sharkclean.com/warranty)

This warranty gives you specific legal rights, and you also may have other rights that vary from state to state.

Some states do not permit the exclusion or limitation of incidental or consequential damages, so the above may not apply to you.





**SharkNinja Operating LLC**  
**US: Needham, MA 02494**  
**CAN: Ville St-Laurent, QC H4S 1A7**  
**1-800-798-7398**  
**sharkclean.com**

Illustrations may differ from actual product. We are constantly striving to improve our products; therefore the specifications contained herein are subject to change without notice.

ROTATOR and SHARK are registered trademarks of SharkNinja Operating LLC.

For SharkNinja U.S. Patent information, visit [sharkninja.com/USPatents](http://sharkninja.com/USPatents)

© 2018 SharkNinja Operating LLC  
NV400\_Series\_IB\_REV\_Mv1  
PRINTED IN CHINA



**@sharkcleaning**