

Shark

Rocket®

QS301Q Series

OWNER'S GUIDE



THANK YOU

for purchasing the Shark® Rocket®



TIP: The model number and serial number are on the QR code label, located on the bottom of the dust cup.

TIP: The date code is located on one of the prongs of the power cord plug.

REGISTER YOUR PURCHASE

- registeryourshark.com
- 1-800-798-7398
- Scan QR code using mobile device

RECORD THIS INFORMATION

Model Number: _____
Date Code: _____
Date of Purchase: _____
(Keep receipt)
Store of Purchase: _____

TECHNICAL SPECIFICATIONS

Voltage: 120V, 60Hz
Watts: 500W
Amps: 4.2A

PLEASE READ CAREFULLY AND KEEP FOR FUTURE REFERENCE.

This Owner's Guide is designed to help you get a complete understanding of your new Shark Rocket ultra-light vacuum.

If you should have a question, please call the Customer Service line at 1-800-798-7398.

CONTENTS

Important Safety Instructions	3
Getting To Know Your Shark® Rocket®	5
Assembling Your Vacuum	7
Choosing the Appropriate Setting	8
Using Your Vacuum in Above-Floor Mode	9
Storage	10
Accessories	11
Maintaining Your Vacuum	13
Emptying the Dust Cup	13
Cleaning the Filters	14
Checking for Blockages	15
Bottom of Floor Nozzle	16
Troubleshooting Guide	17
Warranty	18

IMPORTANT SAFETY INSTRUCTIONS

HOUSEHOLD USE ONLY

To reduce the risk of electric shock, this vacuum cleaner has a polarized plug (one blade is wider than the other). As a safety feature, this plug will fit into a polarized outlet only one way. If the plug does not fit fully into the outlet, reverse the plug. If it still does not fit, contact a qualified electrician. DO NOT force into outlet or try to modify to fit.

⚠ WARNING

TO REDUCE THE RISK OF FIRE, ELECTRIC SHOCK OR INJURY:

GENERAL WARNINGS

When using an electrical appliance, basic precautions should always be followed, including the following:

1. Your vacuum cleaner may consist of a motorized nozzle, wand, hose, and/or vacuum pod. This device contains electrical connections, electrical wiring, and moving parts that potentially present risk to the user.
2. Use only identical replacement parts.
3. Carefully observe and follow the instructions provided below to avoid improper use of the appliance. **DO NOT** use the vacuum for any purpose other than those described in this manual.
4. Before use, carefully inspect all parts for any damage. **DO NOT** use if any parts are damaged.
5. The use of an extension cord is **NOT** recommended.
6. This vacuum cleaner contains no serviceable parts.

USE WARNINGS

7. This appliance can be used by persons with reduced physical, sensory or mental capabilities or lack of experience and knowledge if they have been given supervision or instruction concerning use of the appliance in a safe way and understand the hazards involved.

- Cleaning and user maintenance shall not be made by children. Keep the appliance and its cord out of reach of children. **DO NOT** allow the appliance to be used by children. **DO NOT** allow to be used as a toy. Close supervision is necessary when used near children.
8. Always turn off the vacuum cleaner before connecting or disconnecting any motorized nozzles or other accessories.
 9. **DO NOT** handle plug or vacuum cleaner with wet hands.
 10. **DO NOT** use without filters in place.
 11. Only use Shark® branded filters and accessories. Failure to do so will also void the warranty.
 12. **DO NOT** damage the power cord:
 - a) **DO NOT** pull or carry vacuum cleaner by the cord or use the cord as a handle.
 - b) **DO NOT** unplug by pulling on cord. Grasp the plug, not the cord.
 - c) **DO NOT** run the vacuum cleaner over the power cord, close a door on the cord, pull the cord around sharp corners, or leave the cord near heated surfaces.
 13. **DO NOT** put any objects into nozzle or accessory openings. **DO NOT** use with any opening blocked; keep free of dust, lint, hair, and anything that may reduce airflow.

SAVE THESE INSTRUCTIONS

READ ALL INSTRUCTIONS BEFORE USE

14. **DO NOT** use if nozzle or accessory airflow is restricted. If the air paths or the motorized floor nozzle become blocked, turn the vacuum cleaner off and unplug from electrical outlet. Remove all obstructions before you plug in and turn on the unit again.
 15. Keep nozzle and all vacuum openings away from hair, face, fingers, uncovered feet, or loose clothing.
 16. **DO NOT** use if vacuum cleaner is not working as it should, or has been dropped, damaged, left outdoors, or dropped into water.
 17. Use extra care when cleaning on stairs.
 18. **DO NOT** leave the vacuum cleaner unattended while plugged in.
 19. When powered on, keep the vacuum cleaner moving over the carpet surface at all times to avoid damaging the carpet fibers.
 20. **DO NOT** place vacuum cleaner on unstable surfaces such as chairs or tables.
 21. Your Shark® vacuum may not be designed to stand up on its own. When taking a break from cleaning, you may need to lean it against furniture or a wall, or lay it flat on the floor. Using the vacuum for an application where the unit lacks stability may result in personal injury.
 22. **DO NOT** use to pick up:
 - a) Liquids
 - b) Large objects
 - c) Hard or sharp objects (glass, nails, screws, or coins)
 - d) Large quantities of dust (drywall dust, fireplace ash, or embers). **DO NOT** use as an attachment to power tools for dust collection.
 - e) Smoking or burning objects (hot coals, cigarette butts, or matches)
 - f) Flammable or combustible materials (lighter fluid, gasoline, or kerosene)
 - g) Toxic materials (chlorine bleach, ammonia, or drain cleaner)
23. **DO NOT** use in the following areas:
 - a) Poorly lit areas
 - b) Wet or damp surfaces
 - c) Outdoor areas
 - d) Spaces that are enclosed and may contain explosive or toxic fumes or vapors (lighter fluid, gasoline, kerosene, paint, paint thinners, mothproofing substances, or flammable dust)
 24. Turn off all controls before plugging in or unplugging the vacuum.
 25. Unplug from electrical outlet when not in use and before any maintenance or cleaning.
 26. Hand wash with water only. Washing with cleaning chemicals could damage the unit.
 27. During cleaning or routine maintenance, **DO NOT** cut anything other than hair, fibers, or string wrapped around the brushroll.
 28. Allow all filters to air-dry completely before replacing in the vacuum to prevent liquid from being drawn into electric parts.
 29. Make sure the dust cup and all filters are in place after routine maintenance.
 30. If provided, secure the power cord around the two cord hooks during storage.

GETTING TO KNOW YOUR SHARK® ROCKET®

WELCOME!

Congratulations on your purchase. Use this Owner's Guide to learn about your new vacuum's great features. From assembly to use to maintenance, you will find it all in here.

MAIN UNIT

- A** Power Switch
- B** Handheld Vacuum
- C** Handheld Vacuum Catch
- D** Dust Cup Release
- E** Wand Release
- F** Cord Hooks
- G** Wand
- H** Handheld Vacuum Storage Hook
- I** Nozzle Release
- J** Motorized Floor Nozzle

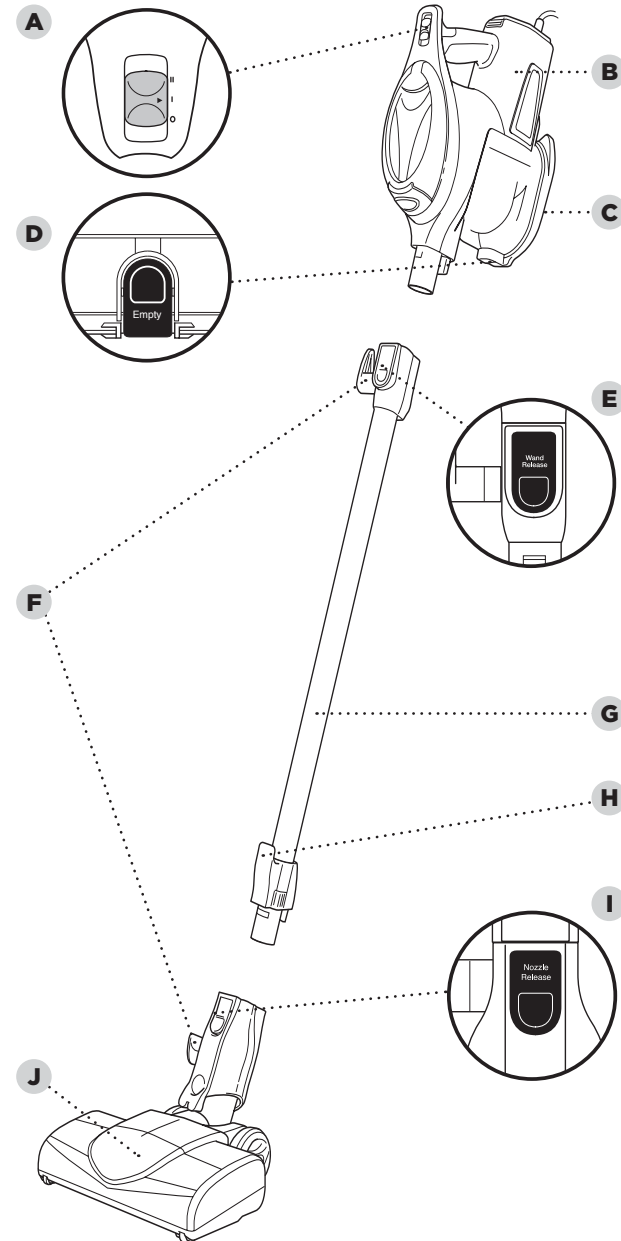

ASSEMBLING YOUR VACUUM

NOTE: Before vacuuming your delicate area rugs or carpet, refer to the manufacturer's recommended cleaning instructions.

STEP 1

- 1 Insert the wand into the motorized floor nozzle connector until it clicks into place.

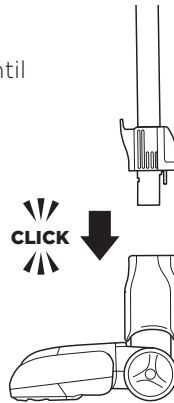

STEP 2

- 2 Insert the handheld vacuum into the top of the wand until it clicks into place.

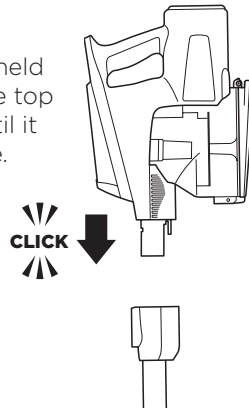

CHOOSING THE APPROPRIATE SETTING

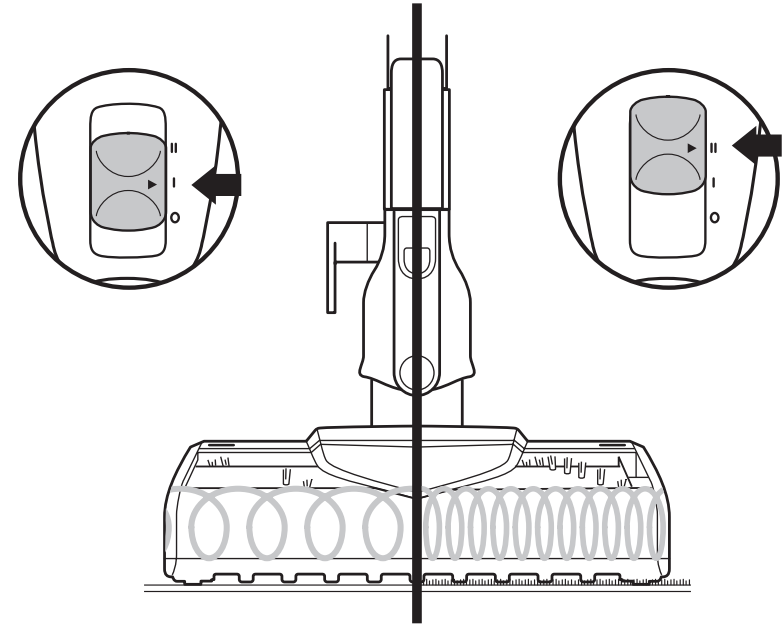

Slide the power switch on the handheld vacuum to the appropriate speed setting.

Setting I, Bare Floor, Small Area Rugs: The brushroll spins slowly to clean bare floors and delicate area rugs.

Setting II, Carpets: The brushroll spins faster to pick up debris below the surface of your carpets.

NOTE: For deep cleaning per ASTM F 608 (embedded dirt in carpets) please ensure switch is set to Setting II, Carpets.

BRUSHROLL INDICATOR LIGHT

Solid Green: When the indicator light on the nozzle is green, then the brushroll is spinning and working as it should.

Solid Red: There is a jam in the brushroll area. Turn your vacuum off and remove any blockages in the nozzle.

No Light: The vacuum is off.

Flashing Red: The vacuum has overheated. See Troubleshooting section.

USING YOUR VACUUM IN ABOVE-FLOOR MODE

WAND

STEP 1

- 1 While holding the vacuum upright, push the Nozzle Release button and pull the wand up to detach it.



STEP 2

- 2 Attach desired cleaning accessory.

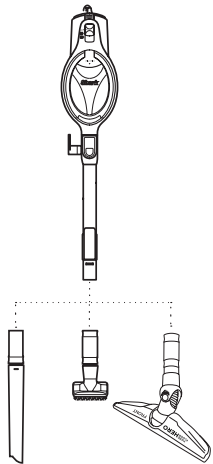

HANDHELD

STEP 1

- 1 Press the Wand Release button on the top of the wand to detach the handheld vacuum.



STEP 2

- 2 Attach desired cleaning accessory.

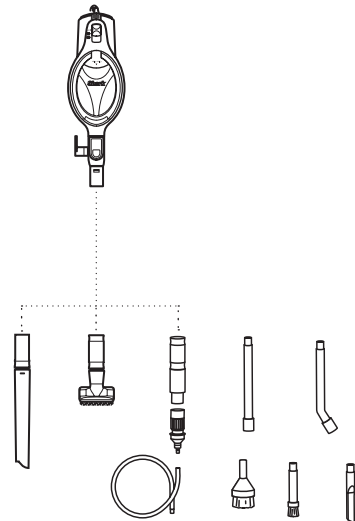

STORAGE

Press the Wand Release button on the top of the wand to release the handheld vacuum. Align the catch on the bottom of the handheld vacuum with the storage hook on the wand. Slide the handheld vacuum down so that the catch hangs from the storage hook. Wrap the cord counterclockwise around the cord hooks, starting with the top hook.

Note: Ensure there is slack where the cord connects to the handheld vacuum.

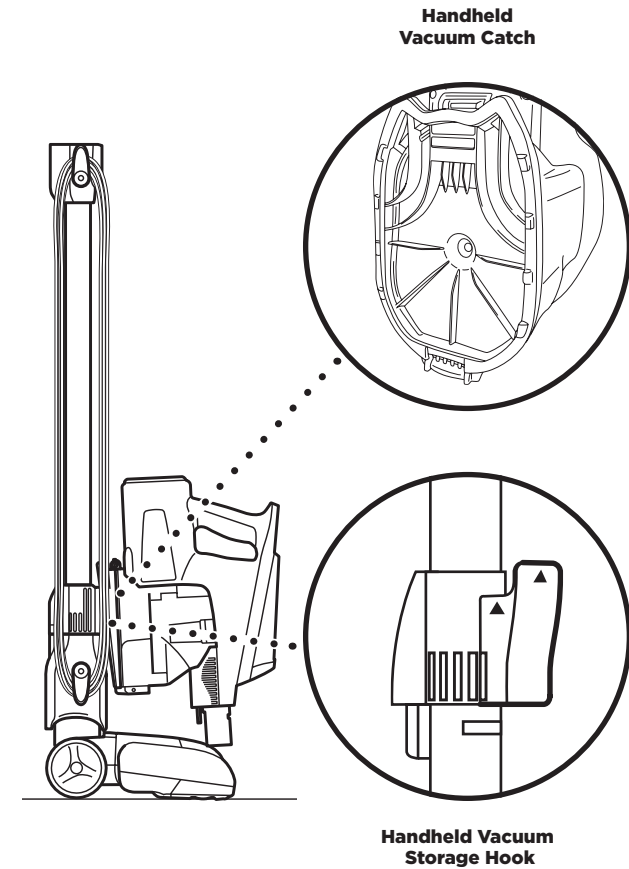

ACCESSORIES

There are a variety of accessories that are compatible with this vacuum series.

The quick start guide shows the select accessories that are included with your model.

To purchase additional accessories, go to sharkaccessories.com

- A 8" Crevice Tool**
This slender tool can access corners, baseboards, tight spaces, and ceilings.
- B 12" Crevice Tool**
Clean in tight spaces or reach baseboards and ceilings with this slim crevice tool.
- C Upholstery Tool**
Perfect for large-particle pickup, dusting, and removing pet hair and lint from furniture and other upholstered surfaces.
- D Home & Car Detail Kit**
Deep-clean your car like a professional detailer, or clean hard-to-reach areas in your home. Micro-sized tools let you clean around delicate objects and access the tightest spaces like car vents and computer keyboards.
- E Pet Multi-Tool**
A single convertible tool for cleaning tough pet messes two ways: first, a stiff bristle brush for cleaning stuck-on debris. Then take off the bristles to reveal an upholstery tool for removing stubborn pet hair.
- F Hard Floor Hero™**
Provides outstanding hard floor cleaning not just for surface litter, but also for stuck-on dust and debris. It is small enough to get into hard-to-reach areas.
- G Dust-Away® Hard Floor Attachment with Microfiber Pad**
Direct suction for cleaning big crumbs and debris. The washable, reusable microfiber pad dusts hardwood and tile floors.
- H Under-Appliance Wand**
Clean under and behind hard-to-move appliances and furniture with this adjustable 36" tool. Flip the extension piece over to clean the underside of appliances.
- I Onboard Storage Clip**
Removable clip attaches to the vacuum wand. Can hold up to two accessories at a time while cleaning or for storage.
- J Wall Mount**
Install the mount to hang your vacuum on the wall for convenient storage. Includes screws, anchors, and instruction sheet with mounting template for easy installation.
- K Accessory Bag**
The perfect place to store all your Shark® cleaning attachments.

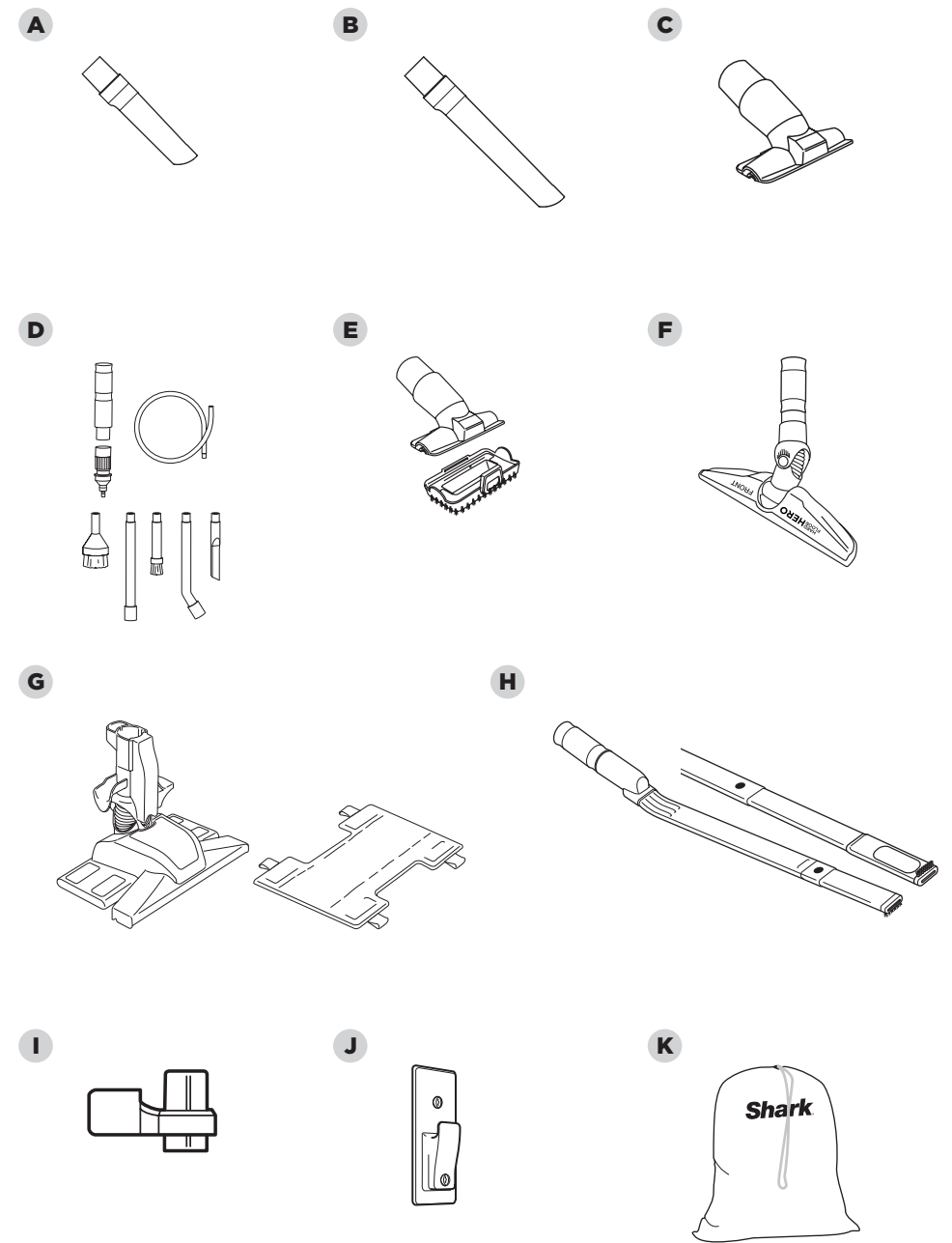

MAINTAINING YOUR VACUUM

IMPORTANT: Clean the dust screen inside the dust cup as required.

NOTE: Empty dust cup when debris reaches the MAX fill line.

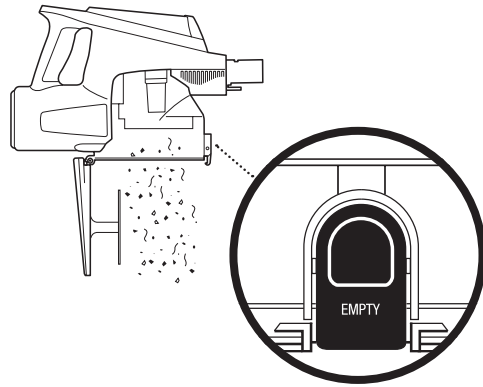

EMPTYING THE DUST CUP

- 1 Press the Wand Release button on the top of the wand to disconnect it from the handheld vacuum.
- 2 Position the handheld vacuum so the dust cup is over a trash bin and press the Empty button on the front. The bottom lid will open, allowing the debris to fall out.
- 3 Once dust cup is empty, close the bottom lid.

RECOMMENDED FILTER CLEANING SCHEDULE:

Pre-Motor Filter Kit

(Foam & Felt)

XFFV300

Clean once a month.

Post-Motor Filter

XFFV300

Clean once every 9 months.

IMPORTANT: If more cleaning is needed, rinse filters with water only and let them air-dry completely.

CLEANING THE FILTERS

1 Pre-Motor (foam and felt):

Lift the latch on the top of the handheld vacuum to open the filter cover. Take out filters and tap loose dirt off them. If more cleaning is needed, rinse filters with water only and let them air-dry completely. To reinstall them, insert the felt filter first, place the foam filter on top of it, and close the filter cover.

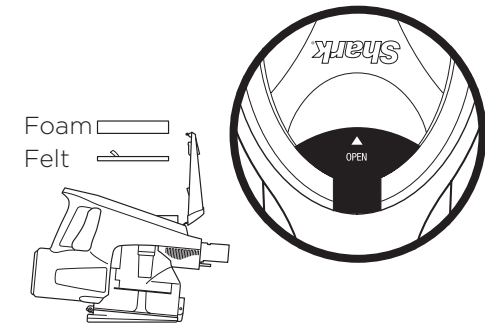

2 Post-Motor:

Lift off the post-motor filter cover below the handle of the handheld vacuum. Remove the filter, rinse it with water only, and let it air-dry completely. Replace the filter, then close the cover, pressing it until it clicks into place.

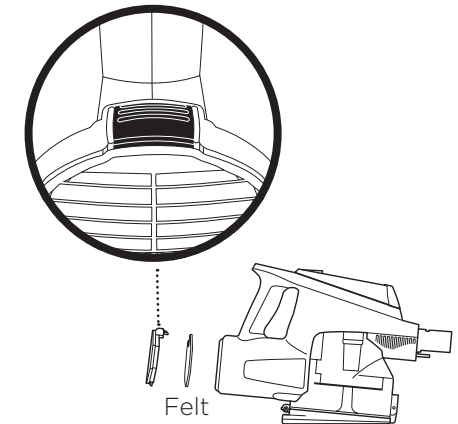

MAINTAINING YOUR VACUUM - Continued

TIP: Ensure the bottom of the floor nozzle is completely sealed and locked before using.

TIP: You do not need any tools to open the floor nozzle, just a coin.

CHECKING FOR BLOCKAGES: HANDHELD AND WAND

- 1 Remove the wand from the handheld vacuum and check all dust cup intake openings.
- 2 Remove the floor nozzle from the wand and check the wand for blockages.

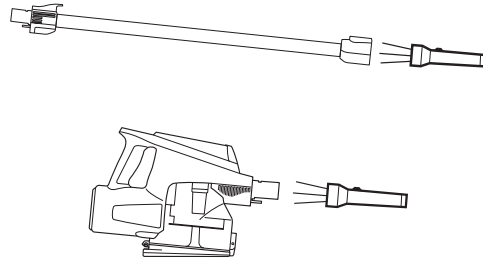

BOTTOM OF FLOOR NOZZLE

- 1 Use the edge of a coin to open the three locks on the bottom of the floor nozzle.

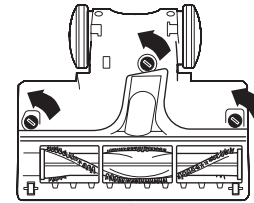

- 2 To access the brushroll, remove the cover from the bottom of the floor nozzle. Shine a flashlight into the nozzle to check for possible blockages.

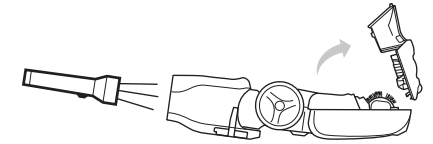

- 3 Run scissors along the groove in the brushroll to cut or clear away any string, carpet fibers, hair, or other debris.

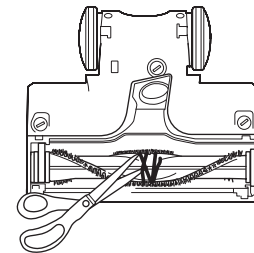

- 4 To reinstall the cover, line it up along the front of the nozzle, then close it, pressing down firmly on all sides until it clicks into place. Use the coin to close the 3 locks.

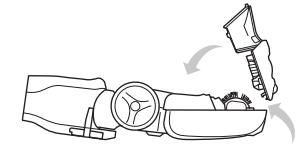

Vacuum is not picking up debris. No suction or light suction. (Refer to Maintenance section for more information.)

- Check filters to see if they need cleaning. Follow instructions for rinsing and completely air-drying the filters before reinserting in the vacuum.
- Dust cup may be full; empty dust cup.
- Check floor nozzle for blockages; clear blockages if required.
- Remove any string, carpet fibers, or hair that may be wrapped around the brushroll.

Vacuum lifts area rugs.

- Suction is powerful. Take care when vacuuming area rugs or rugs with delicately sewn edges.
- Turn off the unit to disengage the brushroll. To restart, slide the power switch to setting I, Bare Floor, Small Area Rugs.

Brushroll does not spin.

- If Brushroll Indicator Light on the floor nozzle turns red, the brushroll has stopped spinning. Immediately turn off and unplug vacuum and remove blockage. Plug back into electrical outlet and turn vacuum on.
- If Brushroll Indicator Light on the floor nozzle is green, the blockage has been successfully cleared. If the light is still red, please contact Customer Service at 1-800-798-7398.

Dust cup bottom lid comes off.

- Reattach the bottom lid of the dust cup by inserting the back of the lid into the metal rod attachment on the dust cup. Press until it clicks into place. Make sure the lid closes and seals completely.

Vacuum turns off on its own or indicator light flashes red.

This vacuum is equipped with a motor-protective thermostat so it will shut off if it overheats. Should this occur, perform the following steps to restart the motor-protective thermostat:

1. Turn vacuum off and unplug it.
2. Empty dust cup and clean filters (see Maintenance section).
3. Check for blockages in hose, accessories, and inlet openings.
4. Allow unit to cool for a minimum of 60 minutes.
5. Plug in vacuum and turn it on.

The Five (5) Year Limited Warranty applies to purchases made from authorized retailers of **SharkNinja Operating LLC**. Warranty coverage applies to the original owner and to the original product only and is not transferable.

SharkNinja warrants that the unit shall be free from defects in material and workmanship for a period of five (5) years from the date of purchase when it is used under normal household conditions and maintained according to the requirements outlined in the Owner's Guide, subject to the following conditions and exclusions:

What is covered by this warranty?

1. The original unit and/or non-wearable components deemed defective, in SharkNinja's sole discretion, will be repaired or replaced up to five (5) years from the original purchase date.
2. In the event a replacement unit is issued, the warranty coverage ends six (6) months following the receipt date of the replacement unit or the remainder of the existing warranty, whichever is later. SharkNinja reserves the right to replace the unit with one of equal or greater value.

What is not covered by this warranty?

1. Normal wear and tear of wearable parts (such as foam filters, HEPA filters, pads, etc.), which require regular maintenance and/or replacement to ensure the proper functioning of your unit, are not covered by this warranty. Replacement parts are available for purchase at sharkaccessories.com.
2. Any unit that has been tampered with or used for commercial purposes.
3. Damage caused by misuse (e.g., vacuuming up water or other liquids), abuse, negligent handling, failure to perform required maintenance (e.g., not cleaning the filters), or damage due to mishandling in transit.
4. Consequential and incidental damages.
5. Defects caused by repair persons not authorized by SharkNinja. These defects include damages caused in the process of shipping, altering, or repairing the SharkNinja product (or any of its parts) when the repair is performed by a repair person not authorized by SharkNinja.
6. Products purchased, used, or operated outside North America.

How to get service

If your appliance fails to operate properly while in use under normal household conditions within the warranty period, visit sharkclean.com/support for product care and maintenance self-help. Our Customer Service Specialists are also available at **1-800-798-7398** to assist with product support and warranty service options, including the possibility of upgrading to our VIP warranty service options for select product categories.

SharkNinja will cover the cost for the customer to send in the unit to us for repair or replacement. A fee of \$24.95 (subject to change) will be charged when SharkNinja ships the repaired or replacement unit.

How to initiate a warranty claim

You must call **1-800-798-7398** to initiate a warranty claim. You will need the receipt as proof of purchase.

A Customer Service Specialist will provide you with return and packing instruction information.

How state law applies

This warranty gives you specific legal rights, and you also may have other rights that vary from state to state. Some states do not permit the exclusion or limitation of incidental or consequential damages, so the above may not apply to you.

PLEASE READ CAREFULLY AND KEEP FOR FUTURE REFERENCE.

This Owner's Guide is designed to help you get a complete understanding of your new Shark® Rocket®.

SharkNinja Operating LLC
US: Needham, MA 02494
CAN: Ville St-Laurent, QC H4S 1A7

1-800-798-7398
sharkclean.com

Illustrations may differ from actual product. We are constantly striving to improve our products; therefore the specifications contained herein are subject to change without notice.

For SharkNinja U.S. Patent information, visit sharkninja.com/uspatents

