

Shark[®]

ROTATOR[®]

NV95

Series

INSTRUCTIONS



sharkclean.com



1-800-798-7398

THANK YOU

for purchasing the Shark® Rotator® Upright Vacuum Cleaner.



TIP: You can find the model number on the rating label located on the back of your unit.



TIP: You can locate the date code on one of the prongs of the power cord plug.

REGISTER YOUR PURCHASE



registeryourshark.com



1-800-798-7398

RECORD THIS INFORMATION

Model Number: _____

Date Code: _____

Date of Purchase (Keep receipt): _____

Store of Purchase: _____

TECHNICAL SPECIFICATIONS

Voltage: 120V, 60Hz

Watts: 1200W

Amps: 10A

PLEASE READ CAREFULLY AND KEEP FOR FUTURE REFERENCE.

This Owner's Guide is designed to help you get a complete understanding of your new Shark Rotator upright vacuum cleaner.

If you should have a question, please call the customer service line at 1-800-798-7398.



CONTENTS

Important Safety Instructions	3
Assembling Your Vacuum	5
Using Your Vacuum in Upright Mode	7
What Does the Brushroll Indicator Light Mean?	7
Using Your Vacuum in Above-Floor Mode	9
The Benefits of Suction Control	9
Helpful Tips	11
Compatible Accessories	13
Maintenance	15
Emptying the Dust Cup	15
Cleaning the Filters	16
Checking for Blockages	17
Bottom of Floor Nozzle	17
Hose and Tubes	18
Troubleshooting Guide	19
Warranty	22





IMPORTANT SAFETY INSTRUCTIONS

FOR HOUSEHOLD USE ONLY

⚠ WARNING

To reduce the risk of injury, fire, electric shock, and property damage resulting from improper use of the appliance, carefully observe the following instructions. This unit contains electrical connections and moving parts that potentially present risk to the user.

THE POWER NOZZLE, WAND, AND HANDLE CONTAIN ELECTRICAL CONNECTIONS:

- These are not serviceable parts.
- Do not use to vacuum any liquids.
- Do not immerse in water.
- If handle/wand is damaged, discontinue use.
- Avoid picking up sharp objects.

- 1** Inspect power cord or plug for any damage before use. DO NOT use vacuum cleaner with a damaged cord or plug. Turn off all controls before plugging or unplugging the vacuum cleaner. Store your vacuum cleaner with the power cord secured around the two cord hooks.
- 2** DO NOT use outdoors or on wet surfaces. Use only on dry surfaces.
- 3** Unplug from electrical outlet when not in use and before servicing.
- 4** If vacuum cleaner is not working as it should, has been dropped, damaged, left outdoors, or dropped into water, return it to SharkNinja Operating LLC for examination, repair, or adjustment.
- 5** The hose contains electrical wires. DO NOT use when damaged, cut, or punctured.
- 6** DO NOT pull or carry vacuum cleaner by the cord or use the cord as a handle.
- 7** DO NOT unplug by pulling on cord. Grasp the plug, not the cord.

- 8** DO NOT handle plug or vacuum cleaner with wet hands.
- 9** DO NOT run the vacuum cleaner over the power cord, close a door on the cord, or pull cord around sharp corners.
- 10** The use of an extension cord is NOT recommended.
- 11** DO NOT leave vacuum cleaner unattended when plugged in.
- 12** Keep cord away from heated surfaces.
- 13** Always turn off the vacuum cleaner before connecting or disconnecting motorized nozzle.

GENERAL USE

- 14** Use only as described in this manual.
- 15** Keep your work area well lit.
- 16** Keep the vacuum cleaner moving over the carpet surface at all times to avoid damaging the carpet fibers.
- 17** DO NOT place vacuum cleaner on unstable surfaces such as chairs or tables.
- 18** DO NOT put any objects into openings. DO NOT use with any opening blocked; keep free of dust, lint, hair, and anything that may reduce airflow.
- 19** DO NOT allow young children to operate this appliance or use as a toy. Close supervision is necessary when any appliance is used near children.
- 20** DO NOT use without dust cup and/or filters in place.





SAVE THESE INSTRUCTIONS

PLEASE READ CAREFULLY BEFORE USE

DUST CUP/FILTERS/ACCESSORIES

Before turning on the vacuum:

- 21** Make sure that all filters are thoroughly dry after routine cleaning.
- 22** Make sure that dust cup and all filters are in place after routine maintenance.
- 23** Make sure accessories are free of blockages.
- 24** Only use Shark-brand filters and accessories (failure to do so will void the warranty).

HOSE ATTACHMENTS

- 25** DO NOT use if airflow is restricted; if the air paths or the motorized floor nozzle become blocked, turn the vacuum cleaner off and unplug from electrical outlet. Remove all obstructions before you turn on the unit again.
- 26** Keep the end of the hose and accessory openings away from face and body.
- 27** Keep cleaning tools and hose suction openings away from hair, face, fingers, uncovered feet, or loose clothing.
- 28** Only use manufacturer's recommended attachments.

GENERAL CLEANING

- 29** DO NOT pick up large-sized objects.
- 30** DO NOT pick up hard or sharp objects such as glass, nails, screws, or coins that could damage the vacuum cleaner.
- 31** DO NOT use to pick up drywall dust, fireplace ash, or embers. DO NOT use as an attachment to power tools for dust collection.

- 32** DO NOT pick up smoking or burning objects such as hot coals, cigarette butts, or matches.
- 33** DO NOT pick up flammable or combustible materials (e.g., lighter fluid, gasoline, or kerosene) or use vacuum in areas where they may be present.
- 34** DO NOT pick up toxic solutions (e.g., chlorine bleach, ammonia, or drain cleaner).
- 35** DO NOT use in an enclosed space where vapors are present from paint, paint thinner, moth-proofing substances, flammable dust, or other explosive or toxic materials.
- 36** DO NOT vacuum up any liquids.
- 37** DO NOT immerse vacuum cleaner in water or other liquids.
- 38** Use extra care when cleaning on stairs.

POLARIZED PLUG

To reduce the risk of electric shock, this vacuum cleaner has a polarized plug (one blade is wider than the other). As a safety feature, this plug will fit into a polarized outlet only one way. If the plug does not fit fully into the outlet, reverse the plug. If it still does not fit, contact a qualified electrician. DO NOT force into outlet or try to modify to fit.



ASSEMBLING YOUR VACUUM

 **TIP:** For quick cord access, rotate upper hook down and remove cord.

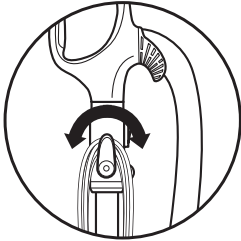

 **TIP:** To store your vacuum, wrap cord around cord hooks.

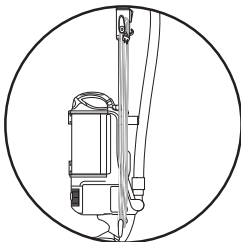

STEP 1

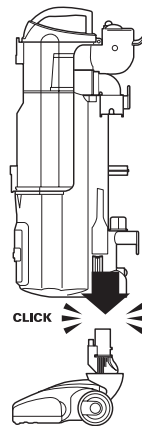

1 Place the vacuum body onto floor nozzle.

STEP 2

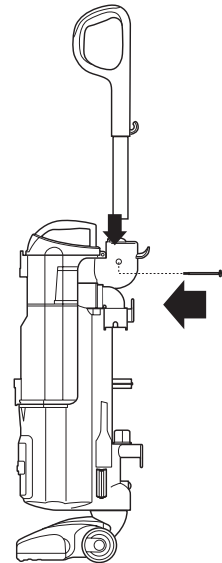

2 Slide handle into top and secure with the provided bolt.

STEP 3

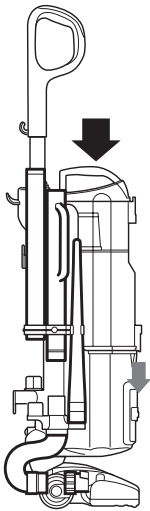

3 Insert extension wand through tool caddy and lower coupling.

STEP 4

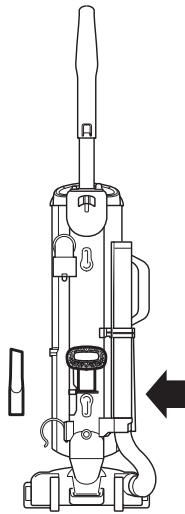

4 Insert the crevice tool and dusting brush into the accessory clips as shown.

STEP 5

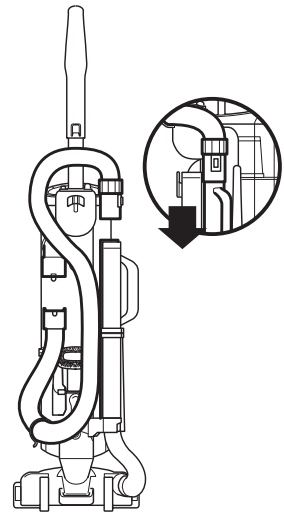

5 Wrap hose around lower hose clip, rest in hose cradle at top of unit and attach to wand.

USING YOUR VACUUM IN UPRIGHT MODE

⚠ WARNING: DO NOT use to pick up drywall dust, fireplace ash, or embers. DO NOT use as an attachment to power tools for dust collection.

NOTE: The brushroll will only spin once the vacuum is reclined back.

WHAT DOES THE BRUSHROLL INDICATOR LIGHT MEAN?

Solid Green

The brushroll is on and working as it should.

Solid Red

There is a jam in the brushroll area. Turn your vacuum off and remove the blockage.

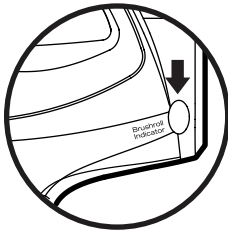

STEP 1

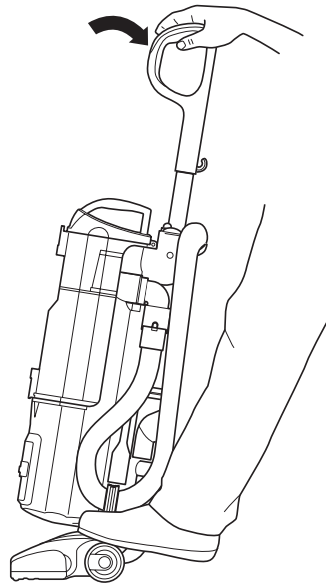

- 1 Place your foot gently on the floor nozzle and tilt the handle back to start cleaning.

STEP 2

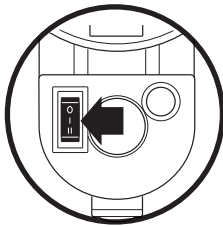

POWER

STEP 3

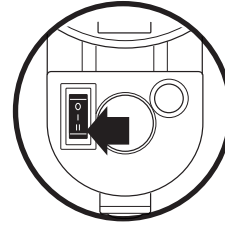

POWER + BRUSHROLL

- 2** Press the On/Off switch to the “I” position to vacuum bare floors or cleaning with the hose (straight suction only). The brushroll will not spin.
- 3** Press the ON/Off switch to the “II” position to engage the motorized floor brush (for vacuuming carpets and rugs). The brushroll indicator lights will illuminate GREEN. If there is a jam, the indicator light on the floor nozzle will illuminate RED. Refer to maintenance (page 17) for instructions on removing blockages.

USING YOUR VACUUM IN ABOVE-FLOOR MODE

THE BENEFITS OF SUCTION CONTROL

Suction Control is a way for you to adjust suction power when you are using different tools or vacuuming different surfaces. For example, if you are feeling resistance vacuuming thick carpet or upholstery, opening the suction control to MIN will help reduce your push/pull effort.

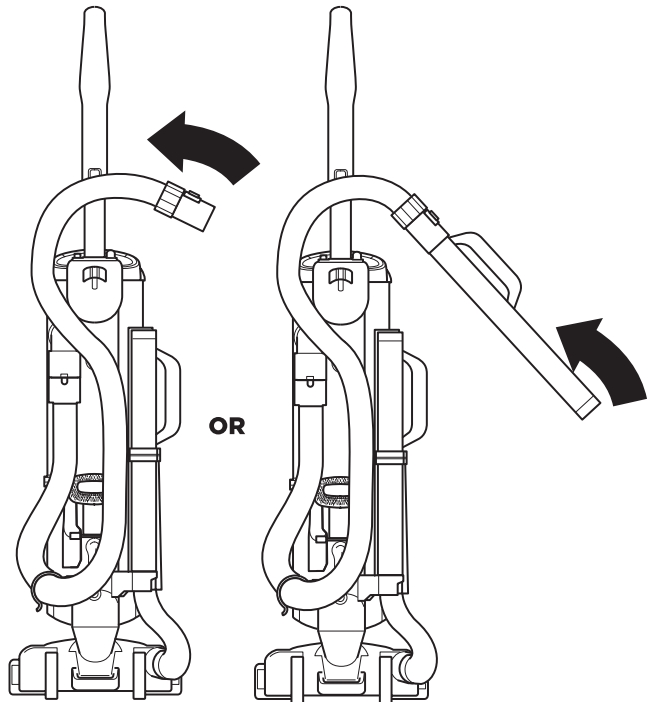

- 1 Remove either the end of the hose or hose with extension wand depending on the amount of reach required.

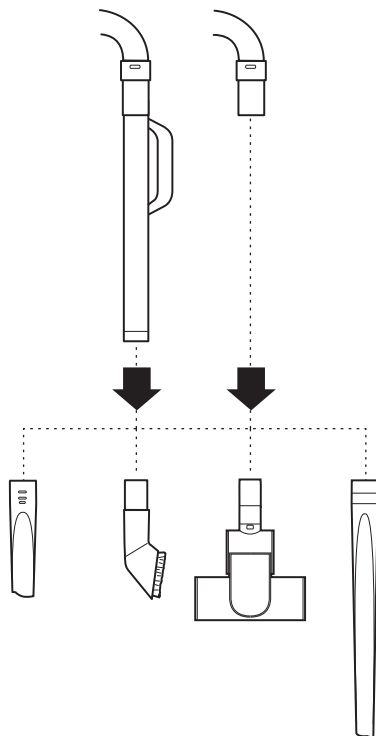

- 2** Attach desired cleaning accessory. Should you need to increase or decrease the amount of suction, refer to Helpful Tips (page 11), Suction Release.

HELPFUL TIPS

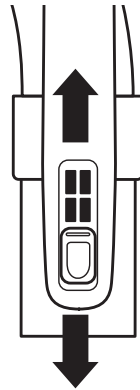

SUCTION CONTROL

- 1** This unit is equipped with a suction control to help with push and pull on high pile carpets, area rugs and to release suction when vacuuming delicate objects or drapery. Located at the end of the hose, slide the button forward with your thumb to minimize suction. Be sure to slide it back for maximum suction.

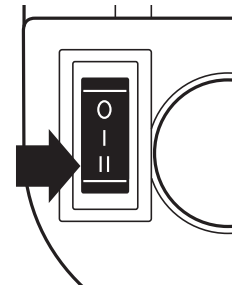
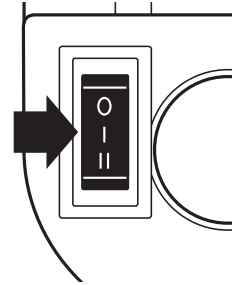

POWER BUTTONS

- 2** The “I” button turns on suction only. This is ideal for use on bare floors, delicate area rugs and for use with accessories.
- 3** The “II” button spins the floor brush, ideal for use on carpeted surfaces. Note: The floor brush will only spin once the vacuum is reclined back.

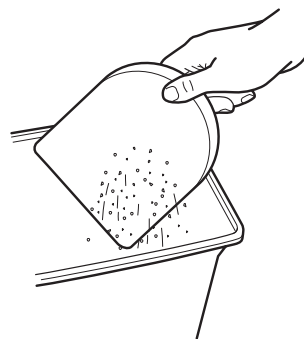
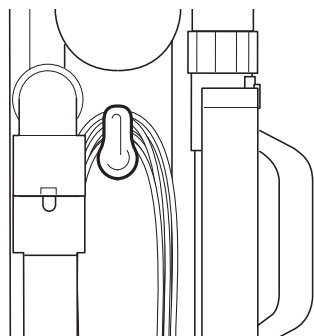

CORD HOOK

- 4** For quick cord access, rotate upper hook 180° and remove cord. Rotate it back to store. Upper cord hook also pivots 90°.

HEIGHT ADJUSTMENT

- 5** This floor nozzle has been optimized to work on all types of carpets as well as bare floors so there is never any need to adjust heights for different floor surfaces.

FILTERS

- 6** Remember to clean your filters regularly under normal use. Also, for optimal performance, tap clean filters between washes as needed.



COMPATIBLE ACCESSORIES

There are a variety of accessories that are compatible with this vacuum series.

The top flap of your box shows the select accessories that are included with your model.

To purchase additional accessories, go to sharkcleanaccessories.com.

A 5.5" Crevice Tool

Gives you extended cleaning reach for small spaces.

B 16" Crevice Tool

Gives you extended cleaning reach for small spaces.

C Dusting Brush

Cleans debris and dust on delicate surfaces.

D Power Brush

Designed for removal of pet hair and ground in dirt from carpeted stairs and upholstery.

A



B

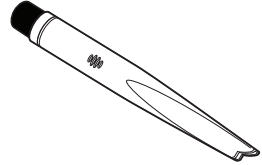

C



D

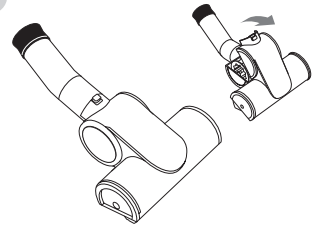

MAINTENANCE

To keep your vacuum's suction power optimal, follow these instructions. Make sure unit is off and cord is unplugged.

⚠ WARNING: To reduce the risk of shock and unintended operation, turn power off and unplug unit before servicing.

Hand wash with water only to prevent damage from cleaning chemicals. Allow ALL filters to dry completely before replacing in the vacuum to prevent liquid from being drawn into electric parts.

★ IMPORTANT: Do not use soap when cleaning the filters.

RECOMMENDED FILTER CLEANING SCHEDULE:

Pre-Motor Filter Kit

(Foam & Felt)
XFF80
Clean once a month.

Post-Motor Filter

(HEPA)
XHF80
Clean once a year.

STEP 1

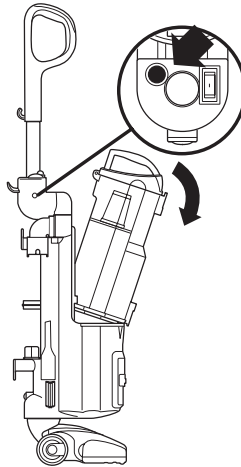

STEP 2

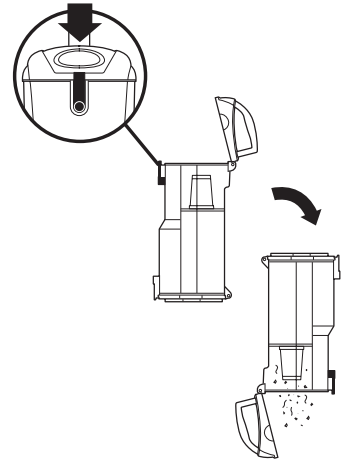

EMPTYING THE DUST CUP

- 1 Press the dust cup release button and lift the dust cup off the vacuum.
- 2 Hold dust cup over a trash bin and slide the bottom empty release latch located midway down the front of the dust cup.

STEP 3

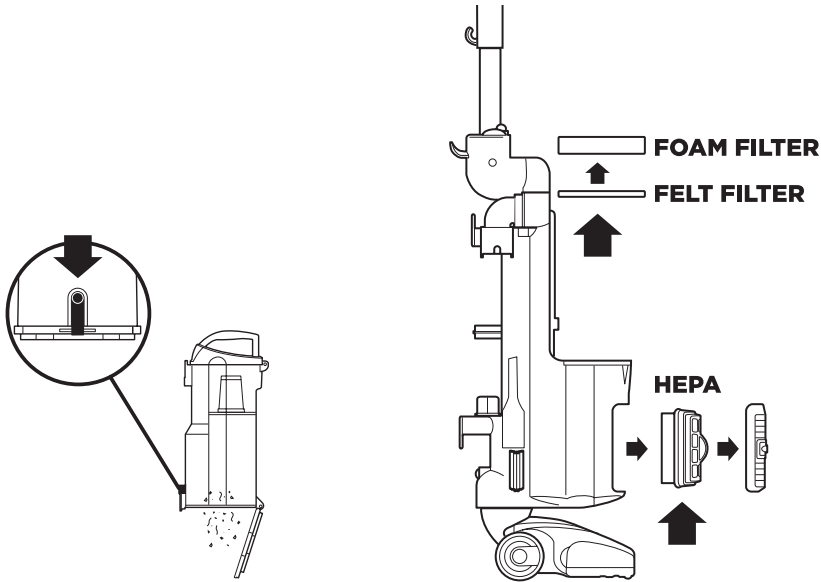

CLEANING THE FILTERS

3 Press top dust-cup release latch to access and clean dust screen as required.

1 Pre-Motor (foam and felt):
With the dust cup removed, take out and rinse the foam and felt filters with water. Tap loose dirt off filters between washes as needed.

2 Post-Motor (HEPA):
To access the HEPA filter, reach under the grill and press the button and pull the grill away from the vacuum. Remove and rinse the HEPA filter.

CHECKING FOR BLOCKAGES

⚠ WARNING: To reduce the risk of shock and unintended operation, turn power off and unplug unit before servicing.

💡 TIP: You can also check for blockages in the hose and tubes. Just remove floor nozzle, dust cup and hose and shine a flashlight in the openings.

STEP 1

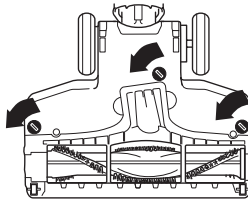

STEP 2

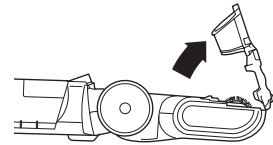

STEP 3

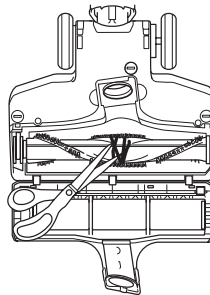

STEP 4

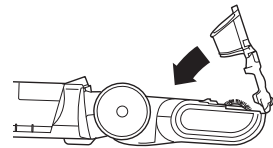

BOTTOM OF FLOOR NOZZLE

- 1 Using a coin, turn the 3 screws on the bottom of the floor nozzle.
- 2 A portion of the base is hinged for better access to the brushroll and exposure to the airway. Shine a flashlight from the bottom of the base to check for blockages.
- 3 Remove any hair, fibers, or debris that may be wrapped around the brushroll. There is a groove that allows a pair of scissors to cut across to loosen the debris.
- 4 To reassemble, replace the base by lining it up along the front of the nozzle. Rotate closed and lock the 3 screws.

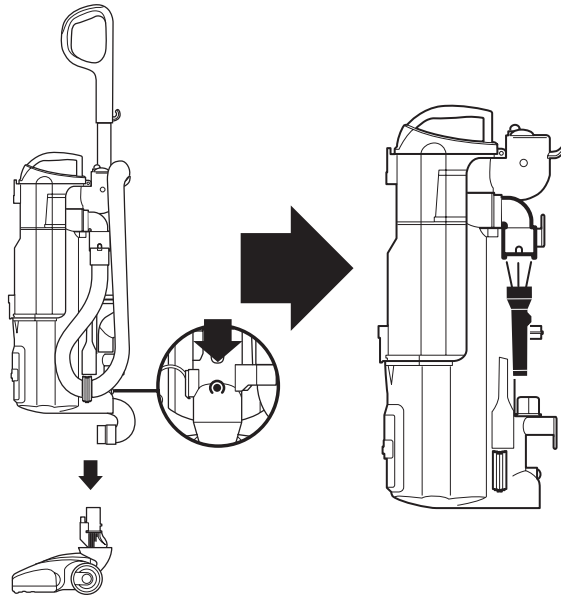

HOSE AND TUBES

- 1 This unit is equipped with a clear cover at the top of the intake duct. Remove floor nozzle and hose and shine a flashlight up from the bottom to check for possible blockage. Remove dustcup and check all intake openings.

TROUBLESHOOTING GUIDE

⚠ WARNING: To reduce the risk of shock and unintended operation, turn power off and unplug unit before servicing.

Vacuum is not picking up debris. No suction or light suction.

(Refer to Maintenance section for more information.)

- Check filters to see if they need cleaning. Follow instructions for rinsing and drying the filters before re-inserting in the vacuum.
- Dust cup may be full; empty dust cup.
- Check hose, hose connections, nozzles, and accessories for blockages; clear blockages if required.
- Remove any string, carpet fibers, or hair that may be wrapped around the brushroll.
- Close the suction release on the handle to increase suction power.

Vacuum lifts area rugs.

- Turn off unit to disengage the brushroll. Ensure brushroll is turned off and restart with the POWER button for suction only cleaning.
- Suction is powerful. Take care when vacuuming area rugs or rugs with delicately sewn edges. Open the suction release on the handle to decrease suction power.

Brushroll does not spin.

- Pull the handle toward you and release the floor nozzle to disengage the auto-off feature.
- Turn the unit on by pressing the “II” button.
- Immediately turn off and unplug vacuum, disconnect the nozzle and remove blockage before reconnecting and turning vacuum back on.

Vacuum turns off on its own.

- This vacuum is equipped with a motor-protective thermostat. If your vacuum overheats, the thermostat will automatically turn the suction motor off. Perform the following steps to restart the motor thermostat:
 1. Turn vacuum off and unplug it.
 2. Empty dust cup and clean filters (see Maintenance section).
 3. Check for blockages in hose, accessories, and inlet openings.
 4. Allow unit to cool for a minimum of 45 minutes.
 5. Plug in vacuum.
 6. Restart the unit using either the POWER button.

Note: If vacuum still does not start, contact Customer Service at 1-800-798-7398.

Shark NINJA FIVE (5) YEAR LIMITED WARRANTY

The 5-Year Limited Warranty applies to purchases made from authorized retailers of **SharkNinja Operating LLC**. Warranty coverage applies to the original owner and to the original product only and is not transferable.

SharkNinja warrants that the unit shall be free from defects in material and workmanship for a period of 5 years from the date of purchase when it is used under normal household conditions and maintained according to the requirements outlined in this instruction manual, subject to the following conditions and exclusions.

What is covered in my warranty?

1. The original unit and/or non-wearable components deemed defective, in SharkNinja's sole discretion, will be repaired or replaced for up to 5 years from the original purchase date.
2. In the rare event that a replacement unit is issued, the warranty coverage ends six months following the receipt date of the replacement unit or the remainder of the existing warranty, whichever is greater. If the unit is replaced, SharkNinja reserves the right to replace the unit with one of equal or greater value.

What is not covered in my warranty?

Our Customer Care/Product Specialists are available to provide all the warranty service options available to you, including the possibility of upgrading to our VIP Warranty Service Options for select product categories.

1. Normal wear and tear of wearable parts such as foam filters, HEPA filters, pads etc., which require regular maintenance and/or replacement to ensure the proper functioning of your unit are not covered by this warranty.
2. Any unit that has been tampered with or used for commercial purposes.
3. SharkNinja will cover the cost for the customer to send in the unit to us for repair or replacement. A fee of \$19.95 for return shipping costs will be charged at the time of return shipment of the repaired or replacement unit.
4. Damage caused by misuse, abuse, or negligent handling, or damage due to mishandling in transit.
5. Consequential and incidental damages.
6. Defects caused by or resulting from damages from shipping or from repairs, service, or alteration to the product or any of its parts which have been performed by a repair person not authorized by SharkNinja.
7. Products purchased, used or operated outside of North America.

Problems with your unit/How to get service

If your appliance fails to operate properly while in use under normal household conditions within the warranty period, visit sharkclean.com for product care/maintenance self-help. Our customer care and product specialists are also available at 1-800-798-7398 to assist with product support and warranty service options.

How to initiate a warranty claim

You can call 1-800-798-7398 to have a customer care specialist assist you. Please note you must call 1-800-798-7398 to initiate a warranty claim. Return and Packing Instruction information will be provided at that time.

For Customer Care hours, visit sharkclean.com

Replacement parts are available for purchase at sharkclean.com. For more information on what are classified as wearable and non-wearable parts, please visit sharkwarranty.com.

This warranty gives you specific legal rights, and you also may have other rights that vary from state to state.

Some states do not permit the exclusion or limitation of incidental or consequential damages, so the above may not apply to you.



SharkNinja Operating LLC
US: Newton, MA 02459
CAN: Ville St-Laurent, QC H4S 1A7
1-800-798-7398
sharkclean.com

Illustrations may differ from actual product. We are constantly striving to improve our products; therefore the specifications contained herein are subject to change without notice.

Rotator and Shark are registered trademarks of SharkNinja Operating LLC.

For SharkNinja U.S. Patent information, visit sharkninja.com/USPatents.

© 2017 SharkNinja Operating LLC
NV95_Series_31_E_170206_2_press
PRINTED IN CHINA



@sharkcleaning