

# ***Shark***<sup>®</sup>

NP317W



[www.SharkClean.com](http://www.SharkClean.com)



1.800.798.7398

# IMPORTANT SAFETY INSTRUCTIONS

## For Household Use Only

**WHEN USING AN ELECTRICAL APPLIANCE, BASIC SAFETY PRECAUTIONS SHOULD ALWAYS BE OBSERVED, INCLUDING THE FOLLOWING:**

**READ ALL INSTRUCTIONS BEFORE USING YOUR SHARK® PORTABLE VAC.**

### **POLARIZED PLUG:**

To reduce the risk of electric shock, this appliance has a polarized plug (one blade is wider than the other). As a safety feature, this plug will fit into a polarized outlet only one way. If the plug does not fit fully into the outlet, reverse the plug. If it still does not fit, contact a qualified electrician.

**DO NOT force into outlet or try to modify to fit.**

**⚠ WARNING:** To reduce the risk of electric shock or injury, do not use outdoors or on wet surfaces.

**This manual covers model number:  
NP317W 40**

### **TECHNICAL SPECIFICATIONS**

Voltage: 120V., 60Hz

Watts: 550 W

Amps: 4.6 A

**⚠ WARNING:**  
**TO REDUCE THE RISK OF FIRE,  
ELECTRIC SHOCK OR INJURY:**

### **GENERAL ELECTRICAL SAFETY:**

1. Unplug from electrical outlet when not in use and before servicing.
2. **DO NOT** use the vacuum cleaner with a damaged cord or plug. This appliance has no serviceable parts. If the appliance is not working as it should or has been dropped, damaged, left outdoors, or dropped into water, return it to EURO-PRO Operating LLC for examination, repair, or adjustment.
3. **DO NOT** pull or carry the vacuum by the cord.
4. **DO NOT** unplug by pulling on the cord; to unplug, grasp the plug, not the cord.
5. **DO NOT** handle the plug or the appliance with wet hands.
6. **DO NOT** run the vacuum over the power cord.
7. **DO NOT** use the cord as a handle.
8. **DO NOT** close a door on the cord.
9. **DO NOT** pull the cord around sharp corners. The use of an extension cord is not recommended.
10. **DO NOT** leave the appliance plugged in when not in use.
11. Keep the cord away from heated surfaces.
12. Turn off all controls before plugging or unplugging the vacuum cleaner.
13. Always turn off this appliance before attaching or removing accessories.



## GENERAL USE:

1. Use only as described in this manual.
2. **DO NOT** put any objects into openings. DO NOT use with any opening blocked; keep free of dust, lint, hair, and anything that may reduce airflow.
3. Keep your work area well lit.
4. **DO NOT** place the vacuum on unstable surfaces such as chairs or tables.
5. **DO NOT** allow young children to operate the vacuum or use as a toy. Close attention is necessary when used by or near children.
6. **DO NOT** use vacuum cleaner if it has been dropped, damaged, left outdoors, or submerged in water. Return to EURO-PRO Operating LLC for examination, repair, or adjustment.
7. **DO NOT** use without Dust Cup and/or filters in place.

## HOSE ATTACHMENTS:

1. **DO NOT** use if airflow is restricted; if the air paths, the hose, or the accessories become blocked, turn the vacuum cleaner off. Remove all obstructions before you turn on the unit again.
2. Keep the end of the hose and accessory openings away from face and body.
3. Keep cleaning tools and hose suction openings away from hair, face, fingers, uncovered feet, and loose clothing.
4. Use only manufacturer's recommended attachments.

## GENERAL CLEANING:

1. **DO NOT** pick up large-sized objects.
2. **DO NOT** pick up hard or sharp objects such as glass, nails, screws, or coins that could damage the vacuum cleaner.
3. **DO NOT** pick up smoking or burning objects such as hot coals, cigarette butts, matches, or fireplace ash.
4. **DO NOT** pick up flammable or combustible materials such as lighter fluid, gasoline, or kerosene or use vacuum in areas where they may be present.
5. **DO NOT** pick up plaster or drywall dust.
6. **DO NOT** pick up toxic solutions such as chlorine bleach, ammonia, or drain cleaner.
7. **DO NOT** use in an enclosed space where vapors are present from paint, paint thinner, moth-proofing substances, flammable dust, or other explosive or toxic materials.
8. **DO NOT** vacuum up any liquids.
9. **DO NOT** immerse the vacuum cleaner in water or other liquids.
10. **DO NOT** use outdoors or on wet surfaces; use only on dry surfaces.
11. Use extra care when cleaning on stairs.

## DUST CUP/FILTERS/ACCESSORIES:

Before turning on the vacuum:

1. Make sure all filters are thoroughly dry after routine cleaning.
2. Make sure the Dust Cup and all filters are in place after routine maintenance.
3. Make sure accessories are free of blockages.
4. Use only filters and accessories provided by EURO-PRO Operating LLC. [Failure to do so will void the warranty.]

# SAVE THESE INSTRUCTIONS

## Getting Started

Use the **Shark®** Portable Vacuum as a stand alone vacuum for spot-cleaning small areas and cleaning furniture, stairs and car interiors.

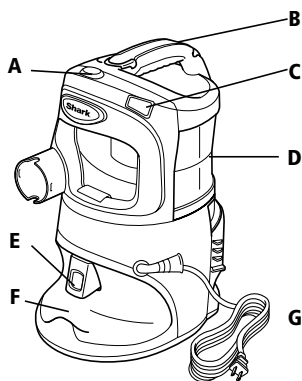

- A** Power Button
- B** Handle
- C** Dust Cup Release Button
- D** Dust Cup
- E** Hose Storage Release Button
- F** Hose Storage
- G** Power Cord



### DUSTING BRUSH

Dust shelves, lamp shades, window blinds, books, furniture and other household items.



### UPHOLSTERY BRUSH

This unique tool was engineered for fast and easy removal of pet hair from upholstery.



### CREVICE TOOL

Reach deep into narrow spaces and clean between cushions, under radiators and baseboards and in hard to reach crevices and corners.

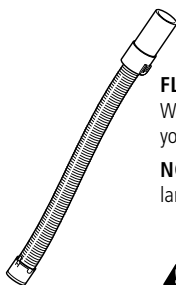

### FLEXIBLE HOSE

With the right cleaning tool in place and the Flexible Hose, you can extend your reach into hard-to-clean areas.

**NOTE:** Use the Flexible Hose without any accessories attached for large debris cleaning.

**⚠ NOTE:** Always turn power off before attaching or detaching accessories.

## How to Use

### STEP 1



- 1 Insert the end of the flexible hose into the connector on the front of the Portable Vacuum. You will hear a “click” when it is in place.

### STEP 2

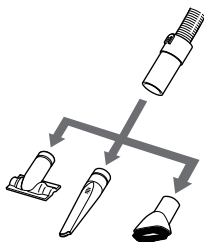

- 2 Attach desired accessory to the end of the flexible hose by pushing it in until it is tightly secured.

### STEP 3

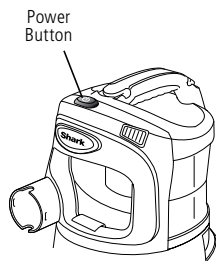

- 3 Press down on the power button to turn the Portable Vacuum on. Press down again to turn the vacuum off.

**NOTE:** Empty Dust Cup after cleaning and periodically during cleaning when it appears full.

## Storage

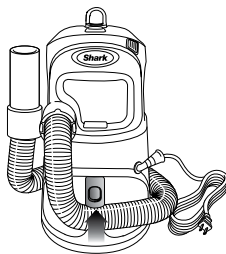

### STORE YOUR VACUUM SAFELY

- 1 Store the dusting brush, upholstery brush and the crevice tool in the zipper storage pouch.
- 2 Wrap the flexible hose around the base of the vacuum and hook the end of it into the hose dock. To release the hose, press the Hose Storage button.
- 3 Wrap the power cord around the unit when storing.

**NOTE:** Empty Dust Cup prior to storing.

## Maintenance

**⚠ CAUTION:** To reduce the risk of electric shock, unplug the unit before performing any cleaning, maintenance, or troubleshooting checks.

**⚠** Reassemble all parts securely before operating vacuum.

For best results, empty Dust Cup after each use or several times during prolonged use or when it reaches the **MAX** fill line. **NEVER OVER-FILL THE DUST CUP.**

### STEP 1



### STEP 2



### STEP 3



### STEP 4

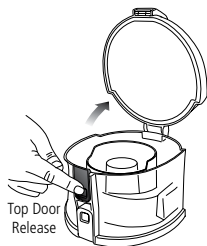

### EMPTYING THE DUST CUP

- 1 Press the Dust Cup Release button and remove the Dust Cup from the vacuum.
- 2 **Option A:** for Quick Empty: Insert the Dust Cup inside a trash bin. Press the bottom door release button to release the door. Tap gently to empty contents. Press the door shut until it clicks.
- 3 **Option B:** For Allergy Sufferers: Wrap a trash bag around the Dust Cup leaving space at the bottom for the door to swing open. Locate the Bottom Door Release button within the trash bag and press to release as you shake the Dust Cup to empty dust and debris. Press the door shut until it clicks.
- 4 To clean the upper part of the Dust Cup, press the Top Door Release button to open. Empty the contents over a trash bin and press the door shut until it clicks.

**NOTE:** Make sure the door is secure before returning the Dust Cup to the vacuum.

**NOTE:** Option B can also be performed outside of the home to further minimize releasing dust back into the air.

## Checking for Blockages

Blockages may cause your vacuum to overheat and shut down. To prevent this from happening, check potential blockage areas after heavy use or if you detect a loss of suction or poor cleaning performance.

- 1 **DUST CUP**  
Dust Cup may be full. Empty Dust Cup.
- 2 **FILTERS (PRE-MOTOR AND POST-MOTOR)**  
Ensure that all of the filters are clean.
- 3 **ACCESSORIES**  
Check intake openings:
  - Crevice Tool
  - Upholstery Brush
  - Dusting Brush
  - Flexible Hose

COMPONENT	MAINTENANCE SCHEDULE
1 Dust Cup	Empty each time you vacuum.
2 Pre-Motor Foam & Felt Filter (Part # XFFP317)	Rinse and air dry every month under normal use.
3 Post-Motor Filter (Part # XHFP317)	Clean once every 12 months under normal use.

- ⚠ DO NOT** operate the vacuum without ALL the filters in place.
- ⚠ DO NOT** operate the vacuum with WET filters.
- ⚠ DO NOT** put any of the filters in the washing machine or dishwasher.
- ⚠ DO NOT** use a hair dryer or other heating methods to dry.

**NOTE:** The material in the filters will discolor over time. This is NORMAL and will not affect the performance of the filters

**IMPORTANT: Loss of Suction may occur** if foam/felt filter is not cleaned every month. Rinse and allow to air dry completely. Tap loose dirt from foam filter as needed in between washing. Foam filter may appear dirty after use—this is normal.

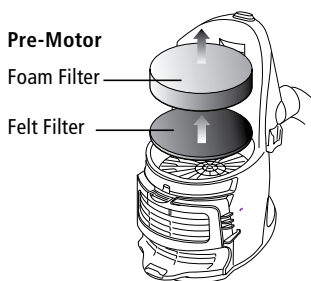

### CLEANING THE PRE-MOTOR FILTERS

- 1 Remove the Dust Cup.
- 2 Remove the Pre-Motor filters out from the top of the motor base.
- 3 Rinse the filters thoroughly under running, lukewarm water until the water runs clear.
- 4 Squeeze out excess water and let air-dry completely before replacing.
- 5 Place the felt filter in first, then the foam filter.
- 6 Replace the Dust Cup.

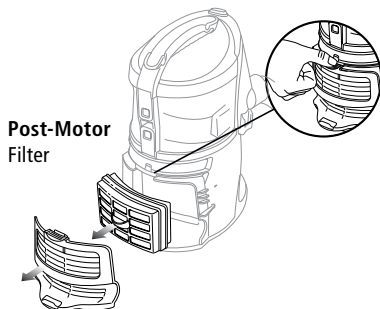

### CLEANING THE POST-MOTOR FILTER

- 1 Remove the filter cover from the vacuum by pulling up on the tab and pulling the cover away from the vacuum. Then remove the post-motor filter.
- 2 Turn the filter over so that the dirty side is on the bottom and vigorously tap it clean against a trash bin.
- 3 Wash the filter running, lukewarm water with the dirty side face down until the water runs clear.
- 4 Allow the Post-Motor filter to air-dry completely before replacing.
- 5 Once the Post-Motor filter is dry, replace it back into the vacuum.
- 6 Replace the cover by inserting the two tabs into the holes at the top and then swinging the cover down until it clicks into place.



# TROUBLE-SHOOTING GUIDE

Customer Service: 800-798-7398

## **Vacuum is not picking up dirt. No suction or light suction.**

- Check Filters to see if they need cleaning. Follow instructions for rinsing and drying the Filters before re-inserting back into the Vacuum. (See "Maintenance" sections for instructions.)
- Dust Cup may be full; empty Dust Cup.
- Check Hose, Hose connections and accessories for blockages; clear blockages if required.
- If Dust Cup is empty, and attachment inlets are clear, check for other blockages. (See "Checking for Blockages" for instructions.)

## **Vacuum turns off on its own.**

- This vacuum cleaner is equipped with a motor protective thermostat. If for some reason your vacuum overheats, the thermostat will automatically turn the unit off. Should this occur, perform the following steps to restart the motor thermostat:
  1. Turn the unit off.
  2. Unplug the vacuum.
  3. Empty the dust cup and clean filters.
  4. Check for blockages in hose, accessories and inlet openings.
  5. Allow the unit to cool for a minimum of 45 minutes.
  6. Plug in the vacuum.
  7. Restart the unit on.

Note: If vacuum still does not start, contact Customer Service at: 1-800-798-7398.

**NOTE:** This appliance has no serviceable parts. Please contact Customer Service at 1-800-798-7398.







# EURO-PRO

## THREE (3) YEAR LIMITED WARRANTY

**EURO-PRO Operating LLC** warrants this product to be free from material defects and workmanship for a period of three (3) years from the date of purchase when utilized for normal household use, subject to the following conditions, exclusions and exceptions.

The liability of **EURO-PRO Operating LLC** is limited solely to the cost of the repair or replacement of the unit at our option. This Limited Warranty does not cover normal wear of parts and does not apply to any unit that has been tampered with or used for commercial purposes. This Limited Warranty does not cover damage caused by misuse, abuse, negligent handling or damage due to faulty packaging or mishandling in transit. This Limited Warranty does not cover damage or defects caused by or resulting from damages from shipping or repairs, service or alteration to the product or any of its parts, which have been performed by a repair person not authorized by **EURO-PRO Operating LLC**.

If your appliance fails to operate properly while in use under normal household conditions within the warranty period, return the complete appliance and accessories, freight prepaid. For assistance with warranty service options or customer support, please call our customer care and product specialists at , call 1 (800) 798-7398 or visit our website [www.sharkclean.com](http://www.sharkclean.com).

If the appliance is found to be defective in material or workmanship, **EURO-PRO Operating LLC** will repair or replace it free of charge. Proof of purchase is required and a fee of \$19.95 will apply to cover the cost of return freight. \*

This Limited Warranty is extended to the original purchaser of the unit and excludes all other legal, implied and/or conventional warranties. The responsibility of **EURO-PRO Operating LLC** if any, is limited to the specific obligations expressly assumed by it under the terms of this Limited Warranty. In no event is **EURO-PRO Operating LLC** liable for incidental or consequential damages to anyone of any nature whatsoever. Some states do not permit the exclusion or limitation of incidental or consequential damages, so the above may not apply to you.

This Limited Warranty gives you specific legal rights, and you may also have other rights which vary from state to state or from province to province.

**\*IMPORTANT: Carefully pack item to avoid damage in shipping. Be sure to include proof of purchase date and to attach tag to item before packing with your name, complete address and phone number with a note giving purchase information, model number and what you believe is the problem with the item. We recommend you insure the package (as damage in shipping is not covered by your Limited Warranty). Mark the outside of your package "ATTENTION CUSTOMER SERVICE".**

---

## Product Registration

Please visit [www.sharkclean.com](http://www.sharkclean.com) or call **1-800-798-7398** to register your new Shark® product within ten (10) days of purchase. You will be asked to provide the store name, date of purchase and model number along with your name and address.

The registration will enable us to contact you in the unlikely event of a product safety notification. By registering you acknowledge to have read and understood the instructions for use, and warnings set forth in the accompanying instructions.

# WE WANT TO HEAR FROM YOU!



[www.SharkClean.com](http://www.SharkClean.com)



1.800.798.7398

## JOIN THE CONVERSATION



@sharkcleaning

## WATCH & LEARN MORE



[youtube.com/shark](http://youtube.com/shark)

### **EURO-PRO Operating LLC**

Newton, MA USA 02459

Ville St. Laurent, Québec Canada H4S 1A7

NP317W\_40\_IB\_ENG\_150604\_1

© 2015 Euro-Pro Operating LLC

Printed in China

For Shark | Ninja U.S. Patent information visit <http://www.europro.com/USPatents>

Illustrations may differ from actual product. We are constantly striving to improve our products, therefore the specifications contained herein are subject to change without notice.