

# Shark®

duo clean™

**NV200**

**Series**

**INSTRUCTIONS**



sharkclean.com



1-800-798-7398

# THANK YOU

for purchasing the Shark® Slim with DuoClean™

---

## REGISTER YOUR PURCHASE

 sharkclean.com

 1-800-798-7398



**TIP:** You can find the model number on the rating label located on the back of your unit.



**TIP:** You can locate the date code on one of the prongs of the power cord plug.

## RECORD THIS INFORMATION

Model Number: \_\_\_\_\_

Date Code: \_\_\_\_\_

Date of Purchase (Keep receipt): \_\_\_\_\_

Store of Purchase: \_\_\_\_\_

## TECHNICAL SPECIFICATIONS

Voltage: 120V., 60Hz

Watts: 650W

Amps: 5.4A

## PLEASE READ CAREFULLY AND KEEP FOR FUTURE REFERENCE.

These instructions are designed to help you get a complete understanding of your new Shark Slim with DuoClean.

If you have any questions, please call the customer service line at 1-800-798-7398.

# CONTENTS

---

<b>Important Safety Instructions</b> .....	<b>3</b>
<b>Getting to Know Your Shark® Slim with DuoClean™</b> .....	<b>5</b>
<b>Assembling Your Vacuum</b> .....	<b>7</b>
<b>Using Your Vacuum in Upright Mode</b> .....	<b>9</b>
What Does the Brushroll Indicator Light Mean? .....	9
<b>Using Your Vacuum in Above-Floor Mode</b> .....	<b>10</b>
<b>Compatible Accessories</b> .....	<b>11</b>
<b>Maintenance</b> .....	<b>13</b>
Emptying the Dust Cup .....	13
Cleaning the Filters .....	14
Checking for Blockages .....	15
Bottom of Floor Nozzle .....	16
Maintaining the Soft Roller .....	17
<b>Troubleshooting Guide</b> .....	<b>19</b>
<b>Warranty</b> .....	<b>22</b>

# IMPORTANT SAFETY INSTRUCTIONS

## FOR HOUSEHOLD USE ONLY

---

### **⚠ WARNING**

**To reduce the risk of injury, fire, electric shock, and property damage resulting from improper use of the appliance, carefully observe the following instructions. This unit contains electrical connections and moving parts that potentially present risk to the user.**

#### **THE FLOOR NOZZLE AND BODY OF THE VACUUM CONTAIN ELECTRICAL CONNECTIONS:**

- These are NOT serviceable parts.
  - DO NOT use to vacuum any liquids.
  - DO NOT immerse in water.
  - If handle/wand is damaged, discontinue use.
- .....

- 1** Inspect power cord and plug for any damage before use. DO NOT use vacuum cleaner with a damaged cord or plug. Turn off all controls before plugging in or unplugging the vacuum cleaner. Store your vacuum cleaner with the power cord secured around the two cord hooks.
- 2** DO NOT use outdoors or on wet surfaces. Use only on dry surfaces.
- 3** Unplug from electrical outlet when not in use and before servicing.
- 4** If vacuum cleaner is not working as it should, or has been dropped, damaged, left outdoors, or submerged in water, return it to SharkNinja Operating LLC for examination, repair, or adjustment.
- 5** DO NOT pull or carry vacuum cleaner by the cord or use the cord as a handle.
- 6** DO NOT unplug by pulling on cord. Grasp the plug, NOT the cord.
- 7** DO NOT handle plug or vacuum cleaner with wet hands.

- 8** DO NOT run the vacuum cleaner over the power cord, close a door on the cord, or pull the cord around sharp corners.
- 9** The use of an extension cord is NOT recommended.
- 10** DO NOT leave vacuum cleaner unattended when plugged in.
- 11** Keep cord away from heated surfaces.
- 12** Always turn off the vacuum cleaner before connecting or disconnecting motorized nozzle.

#### **GENERAL USE**

- 13** Use only as described in this manual.
- 14** Keep your work area well lit.
- 15** Keep the vacuum cleaner moving over the carpet surface at all times to avoid damaging the carpet fibers.
- 16** DO NOT place vacuum cleaner on unstable surfaces such as chairs or tables.
- 17** DO NOT put any objects into openings. DO NOT use with any opening blocked; keep free of dust, lint, hair, and anything that may reduce airflow.
- 18** DO NOT allow young children to operate the appliance or use as a toy. Close supervision is necessary when any appliance is used near children.
- 19** DO NOT use without dust cup and/or filters in place.

# SAVE THESE INSTRUCTIONS

PLEASE READ CAREFULLY BEFORE USE

---

**20** DO NOT use if airflow is restricted. If the air paths or the floor nozzle become blocked, turn the vacuum cleaner off and unplug from electrical outlet. Remove all obstructions before you turn on the unit again.

**21** Keep nozzle away from hair, face, fingers, uncovered feet, or loose clothing.

**22** Only use manufacturer's recommended attachments.

## DUST CUP/FILTERS/ACCESSORIES

Before turning on the vacuum:

**23** Make sure that all filters are thoroughly dry after routine cleaning.

**24** Make sure that dust cup and all filters are in place after routine maintenance.

**25** Make sure accessories are free of blockages and keep openings away from face and body.

**26** Use only Shark® brand filters and accessories. Using other brands will void warranty.

## GENERAL CLEANING

**27** DO NOT vacuum up large objects.

**28** DO NOT vacuum up hard or sharp objects such as glass, nails, screws, or coins that could damage the vacuum cleaner.

**29** DO NOT vacuum up drywall dust, fireplace ash, or embers. DO NOT use as an attachment to power tools for dust collection.

**30** DO NOT vacuum up smoking or burning objects such as hot coals, cigarette butts, or matches.

**31** DO NOT vacuum up flammable or combustible materials (e.g., lighter fluid, gasoline, or kerosene) or use vacuum in areas where they may be present.

**32** DO NOT vacuum up toxic solutions (e.g., chlorine bleach, ammonia, or drain cleaner).

**33** DO NOT use in an enclosed space where vapors are present from paint, paint thinner, moth-proofing substances, flammable dust, or other explosive or toxic materials.

**34** DO NOT vacuum up any liquids.

**35** DO NOT immerse vacuum cleaner in water or other liquids.

**36** Use extra care when cleaning on stairs.

.....

## POLARIZED PLUG

To reduce the risk of electric shock, this vacuum cleaner has a polarized plug (one blade is wider than the other). As a safety feature, this plug will fit into a polarized outlet only one way. If the plug does not fit fully into the outlet, reverse the plug. If it still does not fit, contact a qualified electrician. DO NOT force into outlet or try to modify to fit.

# GETTING TO KNOW YOUR SHARK® SLIM WITH DUOCLEAN™

---

## WELCOME!

Congratulations on your purchase. Use this instruction manual to learn about your new vacuum's great features. From assembly to use to maintenance, you will find it all in here.

## MAIN UNIT

- A** Handle Release Button
- B** Hose
- C** Extension Wand
- D** Extension Wand Release Button
- E** Power Button
- F** Brushroll Indicator Light
- G** Carpet/Hard Floor Button
- H** Dust Cup Release Button
- I** Floor Nozzle Release Button
- J** Motorized Floor Nozzle
- K** Soft Roller Access Button
- L** Headlights
- M** Soft Roller

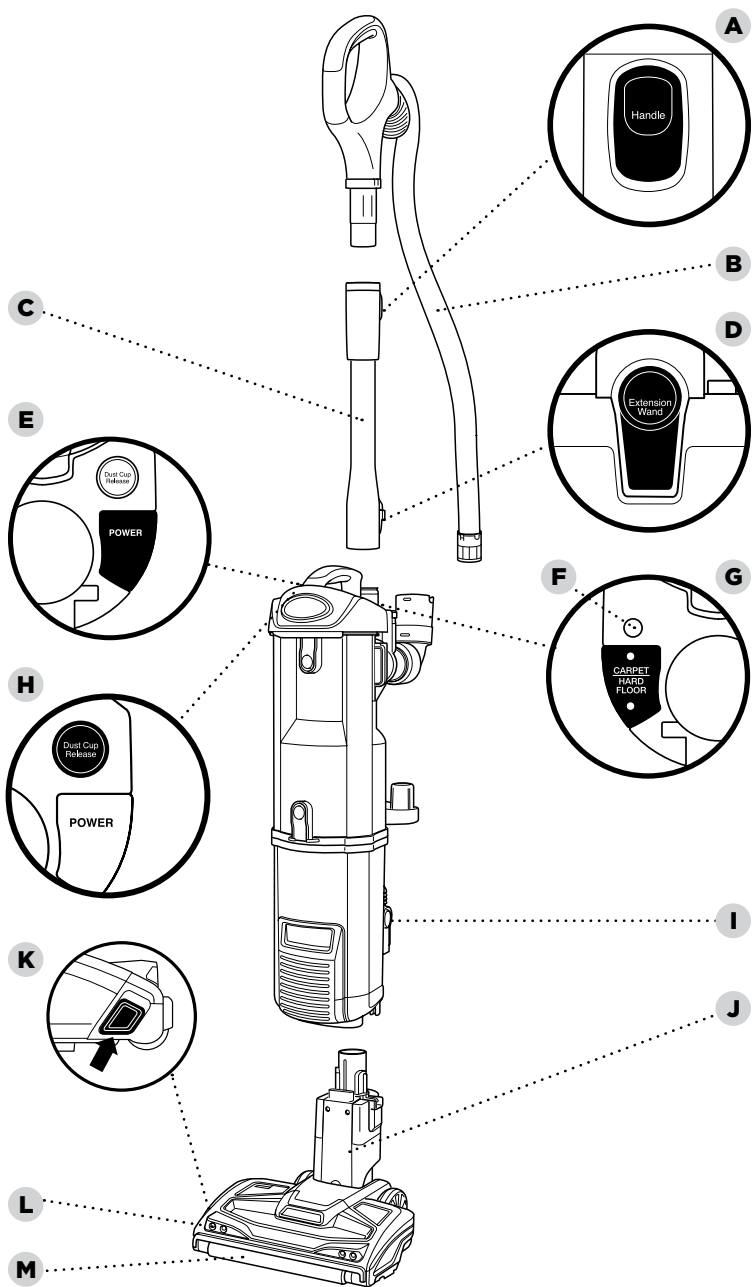

# ASSEMBLING YOUR VACUUM

## DID YOU KNOW?

The Shark® Slim with DuoClean™ is less than 13 pounds without the cord, making it an ultra-light upright.

.....

 **TIP:** Use cord clip located on the back of wand to hold cord in place while vacuuming.

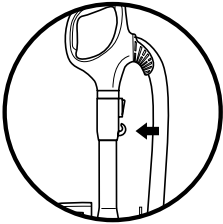

 **TIP:** To store your vacuum, wrap cord around cord hooks.

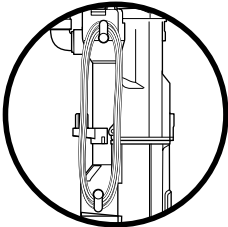

## STEP 1

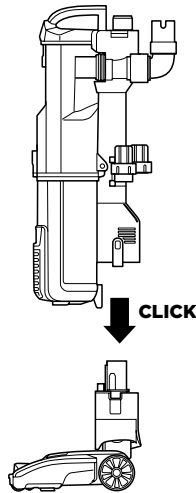

**1** Place the vacuum body onto floor nozzle.

## STEP 2

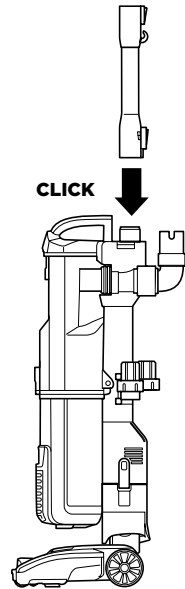

**2** Insert extension wand into top of the vacuum.

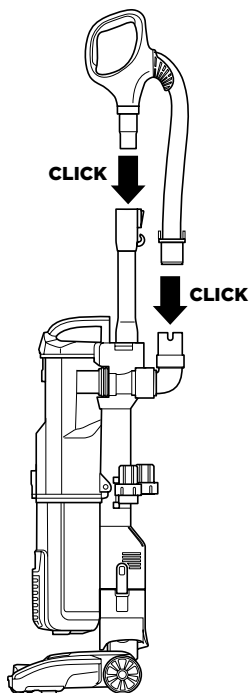
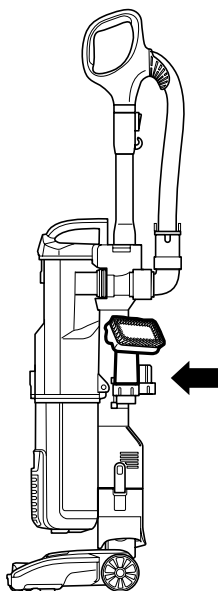
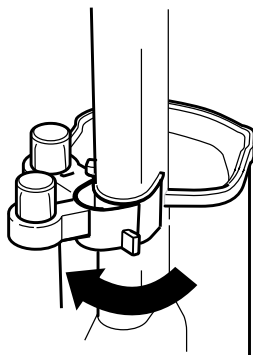

---

**STEP 3****STEP 4****STEP 5**

**3** Insert handle into top of extension wand and click into place. Insert hose into hose connector and click into place.

**4** Store tools on the accessory posts.

**5** To remove the accessory holder, first take off the dust cup. Then pull out the tab on the right side (when viewing from the back of the vacuum.) To replace the accessory holder, align the pins into the hinge on the vacuum and clip back into place.

# USING YOUR VACUUM IN UPRIGHT MODE

**NOTE:** The brushroll will spin only when the vacuum cleaner handle is tilted back.

## WHAT DOES THE BRUSHROLL INDICATOR LIGHT ON THE NOZZLE MEAN?

### Solid Green

The brushroll is on and working as it should.

### Solid Red

There is a jam in the brushroll area. Turn your vacuum off and remove the blockage.

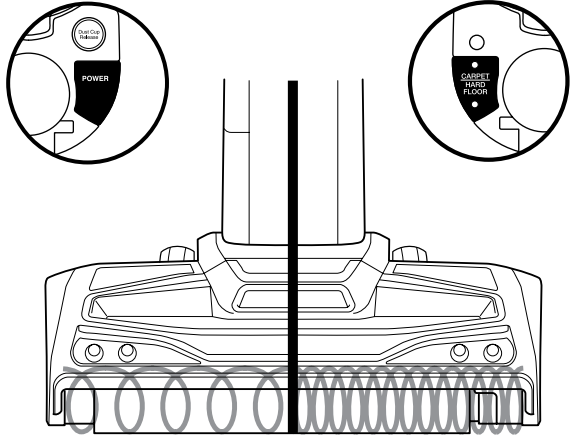
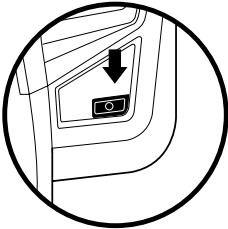

- 1 Plug the power cord into an outlet. Place foot on floor nozzle and tilt handle back.
- 2 Press POWER to turn on the vacuum.
- 3 **To Clean Bare Floors or Area Rugs:**  
In HARD FLOOR mode, the brushroll and the Soft Roller spin together slowly. The Soft Roller traps fine dust and large particles, while the brushroll directs the debris into the suction channel.  
**To Clean High Pile Carpets:**  
In CARPET mode, both brushrolls spin faster, working together to pick up debris below the surface of your carpets.
- 4 The CARPET/HARD FLOOR button lets you control brushroll speed by toggling from one mode to the other. To increase brushroll speed to clean carpets, press the CARPET/HARD FLOOR button so the green light is illuminated. To clean bare floors with slower brushroll speed, press the button again and the light will turn off.

**NOTE:** For deep cleaning per ASTM F 608 (embedded dirt in carpets) please select CARPET mode.

# USING YOUR VACUUM IN ABOVE-FLOOR MODE

## STEP 1

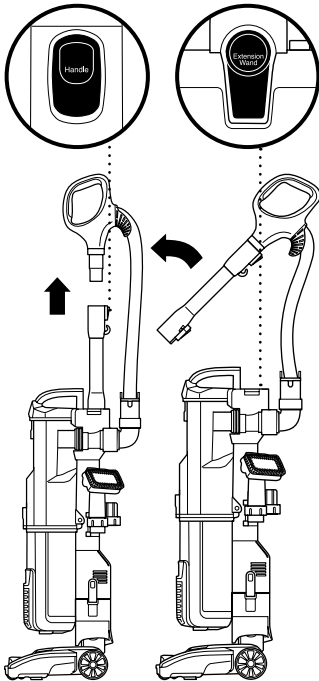

## STEP 2

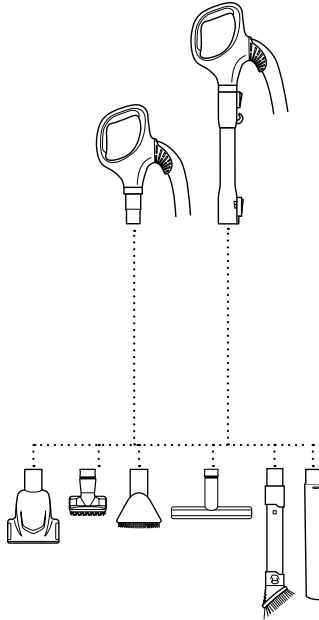

## STEP 3

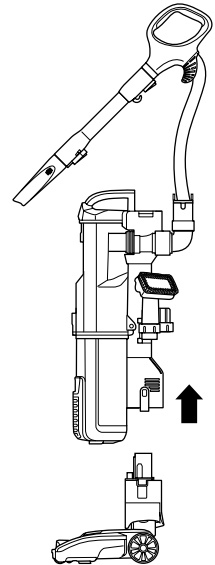

## ABOVE-FLOOR MODE

- 1** Stand the vacuum upright. To attach an accessory directly to the handle, press the Handle release button and lift the handle out of the wand. For more reach, attach an accessory to the end of the wand: press the Extension Wand release button and lift the wand out of the nozzle.
- 2** Attach desired cleaning accessory.

## LIFT-AWAY™ MODE

- 3** To use in Lift-Away mode, press the Floor Nozzle Release button at the bottom of the pod to disconnect from the floor nozzle. Attach desired cleaning accessory to the handle or wand.

# COMPATIBLE ACCESSORIES

---

There are a variety of accessories that are compatible with this vacuum series.

The top flap of your box shows the select accessories that are included with your model.

**To purchase additional accessories, go to [sharkclean.com](http://sharkclean.com)**

## **A 12" Crevice Tool**

Clean tight spaces and reach baseboards and ceilings with this slim crevice tool.

## **B Pet Power Brush**

Designed to remove pet hair and ground-in dirt from carpeted stairs and upholstery.

## **C Dusting Brush**

Cleans hard surfaces and upholstery.

## **D Wide Upholstery Tool**

Perfect for grabbing pet hair and lint from furniture and other upholstered surfaces. Ideal for dusting, removing pet hair, and large-particle pickup.

## **E Pet Multi Tool**

Two tools for cleaning tough pet messes: first, a stiff bristle brush for cleaning stuck-on debris. Then remove the bristles to reveal an upholstery tool for removing stubborn pet hair and lint from furniture.

## **F 18" Flexi Crevice Tool**

Extend and flex to access corners, baseboards, tight spaces or ceilings. The rubberized tip prevents scratches on surfaces.

## **G Duster Crevice**

Two cleaning tools in one—the crevice tool gives you extended cleaning reach for small spaces, while the soft dusting brush cleans a multitude of surfaces.

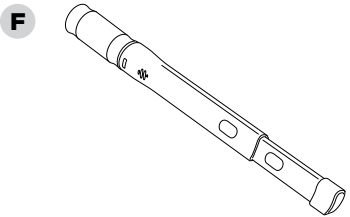
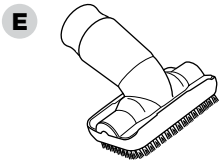
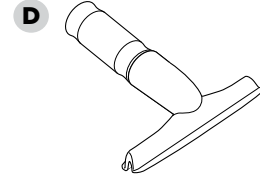
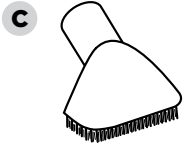
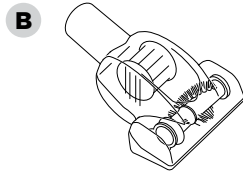
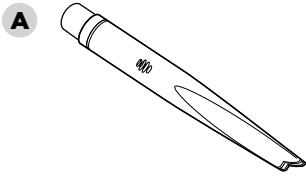

# MAINTENANCE

To keep your vacuum's suction power optimal, follow these instructions. Make sure unit is off and cord is unplugged.

**⚠ WARNING:** To reduce the risk of shock and unintended operation, turn off power and unplug unit before servicing.

Hand wash only with water to prevent damage from cleaning chemicals. Allow ALL filters to dry completely before replacing them in the vacuum to prevent liquid from being drawn into electric parts.

**★ IMPORTANT:** Do not use soap when cleaning the HEPA filter.

## RECOMMENDED FILTER CLEANING SCHEDULE:

### Pre-Motor Filter Kit

(Foam & Felt)

XFF450

Clean every month.

### Post-Motor Filter

(HEPA)

XHF450

Clean every 9 months.

## STEP 1

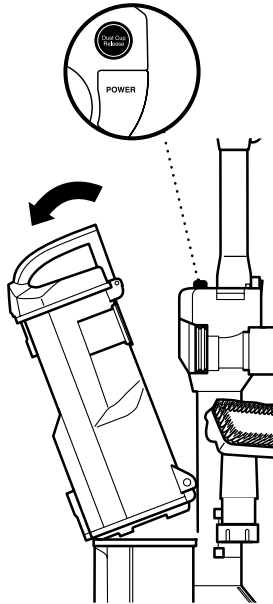

## STEP 2

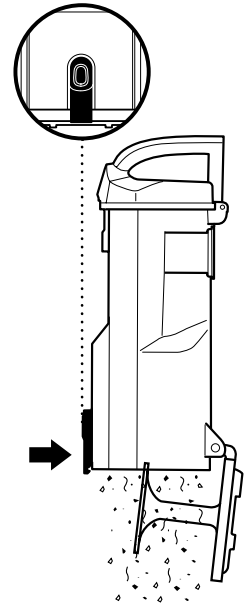

## EMPTYING THE DUST CUP

- 1** Press the Dust Cup Release button and lift dust cup off the vacuum.
- 2** Hold dust cup over a trash bin and press the latch on the bottom of the dust cup to empty it.

### STEP 3

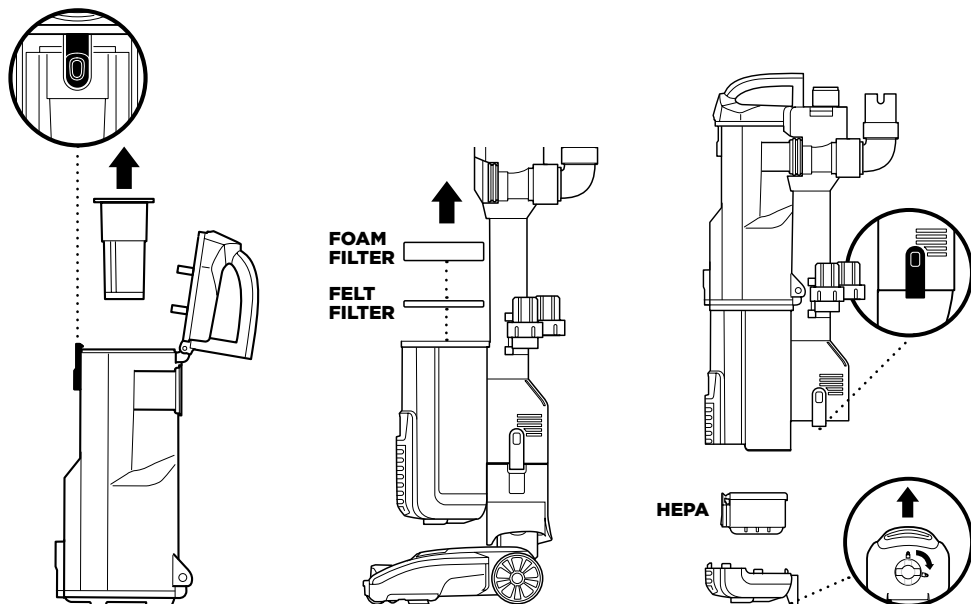

- 3** Press top Dust Cup Release latch to access dust screen and remove built-up debris as required.

### CLEANING THE FILTERS

#### **1 Pre-Motor (foam and felt):**

With the dust cup removed, take the foam and felt filters out and rinse them with water. Be sure to let all filters air-dry completely before reinstalling. Tap loose dirt off filters between washes as needed.

#### **2 Post-Motor (HEPA):**

To access the HEPA filter, remove the floor nozzle by pressing the Nozzle Release button on the side of the vacuum. To release the filter frame, turn latch to the unlock symbol. Press the tab on the HEPA filter to remove, then rinse the filter with water. Be sure to let all filters air-dry completely before reinstalling.

# MAINTENANCE - CONT.

**⚠ WARNING:** To reduce the risk of shock and unintended operation, turn off power and unplug unit before servicing.

**⚠ WARNING:** When cleaning brushroll, be sure not to cut anything other than hair, string, fibers, or other debris.

**💡 TIP:** Ensure the bottom of the floor nozzle is completely sealed and locked before using.

**💡 TIP:** You do not need any tools to open the floor nozzle—just a coin.

## STEP 1

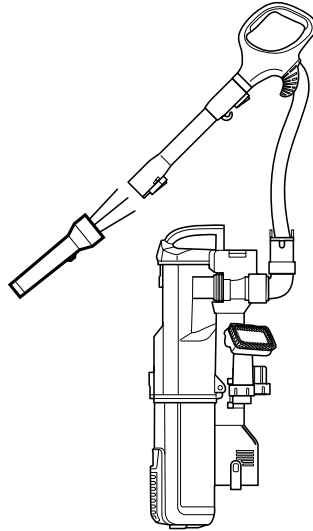

## STEP 2

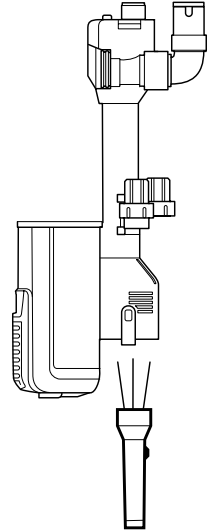

### CHECKING FOR BLOCKAGES: HOSE AND TUBES

- 1 Remove floor nozzle and extension wand.
- 2 Check all intake openings on the dust cup for blockages. Then remove dust cup and hose to check intake opening and hose elbow for blockages.



---

### STEP 1

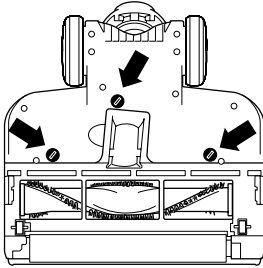

### STEP 2

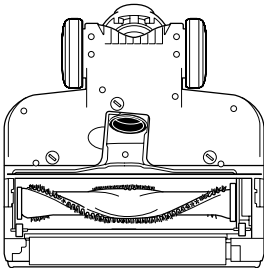

### STEP 3

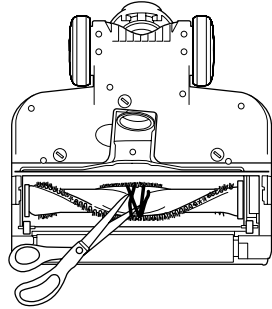

## BOTTOM OF FLOOR NOZZLE

- 1** Open the three locks on the bottom of the floor nozzle. To open each lock, insert the edge of a coin into the slot and turn counterclockwise.
- 2** Lift tabs and pull up to expose the airway, then tilt the nozzle neck back to straighten. Use a flashlight to check for blockages in the airway.
- 3** Remove any string, carpet fibers, or hair that may be wrapped around the brushroll. To loosen debris, run scissors along the groove in the brushroll. To close the nozzle, push down until it clicks into place, then fasten the locks with a coin.

# MAINTENANCE - CONT.

**⚠ WARNING:** To reduce the risk of shock and unintended operation, turn off power and unplug unit before servicing.

**⚠ WARNING:** When cleaning brushroll, be sure to not cut anything other than hair, string, fibers, or other debris.

**💡 TIP:** Ensure the bottom of the floor nozzle is completely sealed and locked before using.

**💡 TIP:** You do not need any tools to open the floor nozzle—just a coin.

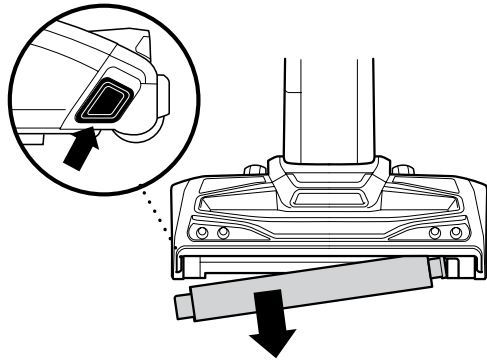

## MAINTAINING THE SOFT ROLLER

- 1 Slide the Soft Roller access button up to remove the Soft Roller.

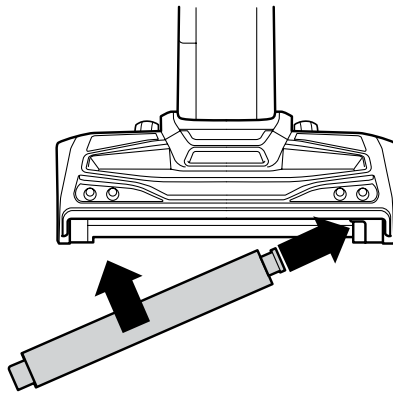

- 2** To clean Soft Roller, first tap lightly to loosen debris, then wipe with a dry towel to remove any fibers or hair in the teeth behind the Soft Roller.
- 3** Wash the Soft Roller as needed. Use only water, and let air-dry completely for at least 24 hours.
- 4** Reinsert the Soft Roller by sliding it into the front of the nozzle until it clicks into place.

# TROUBLESHOOTING GUIDE

---

**⚠ WARNING: To reduce the risk of shock and unintended operation, turn off power and unplug unit before servicing.**

**Vacuum is not picking up debris. No suction or light suction.**  
(Refer to Maintenance section for more information.)

- Check filters to see if they need cleaning. Follow instructions for rinsing and completely air-drying the filters before reinserting into the vacuum.
- Dust cup may be full; empty dust cup.
- Check floor nozzle for blockages; clear blockages if required.
- Remove any string, carpet fibers, or hair that may be wrapped around the brushroll.

**Vacuum lifts area rugs.**

- Suction is powerful. Take care when vacuuming area rugs or rugs with delicately sewn edges.
- Turn off the unit to disengage the brushroll and restart with the power button.

**Brushroll/Soft Roller does not spin.**

- If Brushroll Indicator Light on the floor nozzle turns red, the brushroll and/or Soft Roller have stopped spinning. Immediately turn off and unplug vacuum and remove blockage. Plug the unit into an electrical outlet and turn on vacuum.
- If Brushroll Indicator Light on the floor nozzle is green, the blockage has been successfully cleared. If the light is still red, please contact customer service at 1-800-798-7398.
- With the power on, recline the handle, which will automatically turn on the brushrolls.

**Vacuum turns off on its own or indicator light flashes red.**

This vacuum is equipped with a motor-protective thermostat so the vacuum will shut off if it overheats. Should this occur, perform the following steps to restart the thermostat:

1. Turn off vacuum and unplug it.
2. Empty dust cup and clean filters (see Maintenance section).
3. Check for blockages on the brushrolls and remove all hair and carpet fibers.
4. Allow unit to cool for a minimum of 45 minutes.
5. Plug in vacuum and turn it on.





# **Shark** | **NINJA** **FIVE (5) YEAR LIMITED WARRANTY**

---

The 5-Year Limited Warranty applies to purchases made from authorized retailers of **SharkNinja Operating LLC**. Warranty coverage applies to the original owner and to the original product only and is not transferable.

SharkNinja warrants that the unit shall be free from defects in material and workmanship for a period of 5 years from the date of purchase when it is used under normal household conditions and maintained according to the requirements outlined in this instruction manual, subject to the following conditions and exclusions.

## **What is covered in my warranty?**

1. The original unit and/or non-wearable components deemed defective, in SharkNinja's sole discretion, will be repaired or replaced for up to 5 years from the original purchase date.
2. In the rare event that a replacement unit is issued, the warranty coverage ends six months following the receipt date of the replacement unit or the remainder of the existing warranty, whichever is greater. If the unit is replaced, SharkNinja reserves the right to replace the unit with one of equal or greater value.

## **What is not covered in my warranty?**

Our Customer Care/Product Specialists are available to provide all the warranty service options available to you, including the possibility of upgrading to our VIP Warranty Service Options for select product categories.

1. Normal wear and tear of wearable parts such as foam filters, HEPA filters, pads etc., which require regular maintenance and/or replacement to ensure the proper functioning of your unit are not covered by this warranty.
2. Any unit that has been tampered with or used for commercial purposes.
3. SharkNinja will cover the cost for the customer to send in the unit to us for repair or replacement. A fee of \$19.95 for return shipping costs will be charged at the time of return shipment of the repaired or replacement unit. Our Customer Care /Product Specialists are available to provide all the warranty service options available to you including upgrading to our VIP Warranty Service Options.
4. Damage caused by misuse, abuse, or negligent handling, or damage due to mishandling in transit.
5. Consequential and incidental damages.
6. Defects caused by or resulting from damages from shipping or repairs, service, or alteration to the product or any of its parts which have been performed by a repair person not authorized by SharkNinja.
7. Products purchased, used or operated outside of North America.

## **Problems with your unit/How to get service**

If your appliance fails to operate properly while in use under normal household conditions within the warranty period, visit [sharkclean.com](http://sharkclean.com) for product care/maintenance self- help. Our customer care and product specialists are also available at 1-800-798-7398 to assist with product support and warranty service options.

## **How to initiate a warranty claim**

You can call 1-800-798-7398 to have a customer care specialist assist you. Please note you must call 1-800-798-7398 to initiate a warranty claim. Return and Packing Instruction information will be provided at that time.

Replacement parts are available for purchase at [sharkclean.com](http://sharkclean.com). For more information on which parts are classified as wearable and non-wearable, please visit [sharkwarranty.com](http://sharkwarranty.com).

This warranty gives you specific legal rights, and you also may have other rights that vary from state to state.

Some states do not permit the exclusion or limitation of incidental or consequential damages, so the above may not apply to you.



**SharkNinja Operating LLC**  
**US: Newton, MA 02459**  
**CAN: Ville St-Laurent, QC H4S 1A7**  
**1-800-798-7398**  
**sharkclean.com**

Illustrations may differ from actual product. We are constantly striving to improve our products; therefore the specifications contained herein are subject to change without notice.

SHARK is registered trademark of SharkNinja Operating LLC.

DUOCLEAN and LIFT-AWAY are trademarks of SharkNinja Operating LLC.

For SharkNinja U.S. Patent information visit [sharkninja.com/USPatents](http://sharkninja.com/USPatents)

© 2017 SharkNinja Operating LLC  
NV200\_Series\_IB\_170403  
PRINTED IN CHINA



**@sharkcleaning**