

Shark

Navigator™ Upright Vacuum

NV100 Series

OWNER'S GUIDE

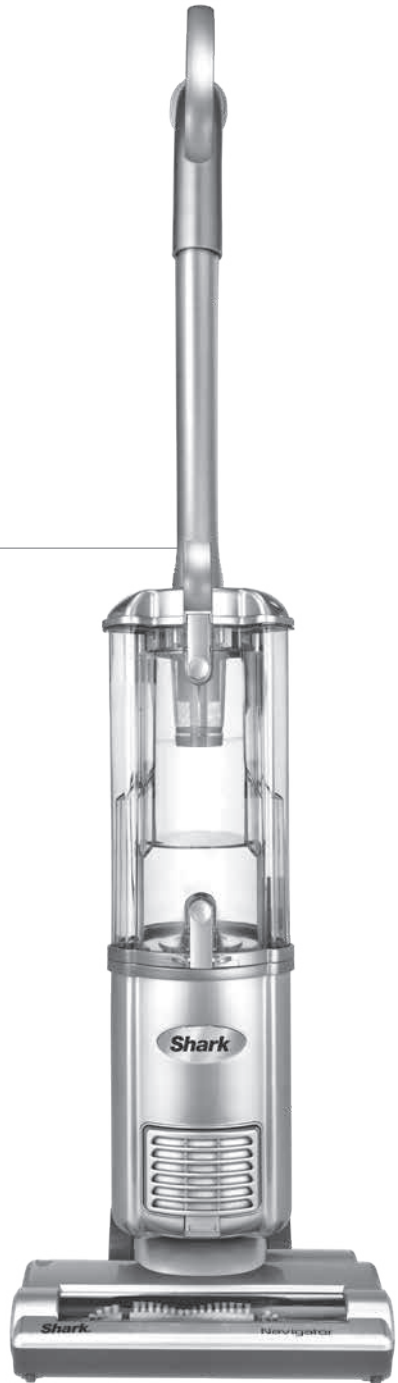

IMPORTANT SAFETY INSTRUCTIONS

FOR HOUSEHOLD USE ONLY • PLEASE READ CAREFULLY BEFORE USE

If the plug does not fit fully into the outlet, reverse the plug. If it still does not fit, contact a qualified electrician. **DO NOT** force into outlet or try to modify to fit.

⚠ WARNING

To reduce the risk of fire, electric shock, injury, or property damage:

GENERAL WARNINGS

Your vacuum cleaner may consist of a motorized nozzle, wand, hose, and/or vacuum pod. This device contains electrical connections, electrical wiring, and moving parts that potentially present risk to the user.

1. Use only identical replacement parts.
2. Carefully observe and follow the instructions provided below to avoid improper use of the appliance. **DO NOT** use the vacuum for any purpose other than those described in this manual.
3. Before use, carefully inspect all parts for any damage. **DO NOT** use if any parts are damaged.
4. The use of an extension cord is **NOT** recommended.
5. This vacuum cleaner contains no serviceable parts.

USE WARNINGS

6. **DO NOT** allow the appliance to be used by children. Close supervision is necessary when used near children. This is not a toy.
7. Always turn off the vacuum cleaner before connecting or disconnecting any motorized nozzles or other accessories.
8. **DO NOT** handle plug or vacuum cleaner with wet hands.
9. **DO NOT** use without filters in place.
10. Only use Shark® branded filters and accessories. Failure to do so will also void the warranty.

11. **DO NOT** damage the power cord:
 - a) **DO NOT** pull or carry vacuum cleaner by the cord or use the cord as a handle.
 - b) **DO NOT** unplug by pulling on cord. Grasp the plug, not the cord.
 - c) **DO NOT** run the vacuum cleaner over the power cord, close a door on the cord, pull the cord around sharp corners, or leave the cord near heated surfaces.
12. **DO NOT** put any objects into nozzle or accessory openings. **DO NOT** use with any opening blocked; keep free of dust, lint, hair, and anything that may reduce airflow.
13. **DO NOT** use if nozzle or accessory airflow is restricted. If the air paths or the motorized floor nozzle become blocked, turn the vacuum cleaner off and unplug from electrical outlet. Remove all obstructions before you plug in and turn on the unit again.
14. Keep nozzle and all vacuum openings away from hair, face, fingers, uncovered feet, or loose clothing.
15. **DO NOT** use if vacuum cleaner is not working as it should, or has been dropped, damaged, left outdoors, or dropped into water.
16. Use extra care when cleaning on stairs.
17. **DO NOT** leave the vacuum cleaner unattended while plugged in.
18. When powered on, keep the vacuum cleaner moving over the carpet surface at all times to avoid damaging the carpet fibers.

19. **DO NOT** place vacuum cleaner on unstable surfaces such as chairs or tables.
20. Your Shark® vacuum may not be designed to stand up on its own. When taking a break from cleaning, you may need to lean it against furniture or a wall, or lay it flat on the floor. Using the vacuum for an application where the unit lacks stability may result in personal injury.
21. **DO NOT** use to pick up:
 - a) Liquids
 - b) Large objects
 - c) Hard or sharp objects (glass, nails, screws, or coins)
 - d) Large quantities of dust (drywall dust, fireplace ash, or embers). **DO NOT** use as an attachment to power tools for dust collection.
 - e) Smoking or burning objects (hot coals, cigarette butts, or matches)
 - f) Flammable or combustible materials (lighter fluid, gasoline, or kerosene)
 - g) Toxic materials (chlorine bleach, ammonia, or drain cleaner)
22. **DO NOT** use in the following areas:
 - a) Poorly lit areas
 - b) Wet or damp surfaces
 - c) Outdoor areas
 - d) Spaces that are enclosed and may contain explosive or toxic fumes or vapors (lighter fluid, gasoline, kerosene, paint, paint thinners, mothproofing substances, or flammable dust)
23. Turn off all controls before plugging in or unplugging the vacuum.
24. Unplug from electrical outlet when not in use and before any maintenance or cleaning.
25. Hand wash with water only. Washing with cleaning chemicals could damage the unit.
26. During cleaning or routine maintenance, **DO NOT** cut anything other than hair, fibers, or string wrapped around the brushroll.
27. Allow all filters to air-dry completely before replacing in the vacuum to prevent liquid from being drawn into electric parts.
28. Make sure the dust cup and all filters are in place after routine maintenance.
29. If provided, secure the power cord around the two cord hooks during storage.

To reduce the risk of electric shock, this appliance has a polarized plug (one blade is wider than the other). This plug will fit in a polarized outlet only one way. If the plug does not fit fully in the outlet, reverse the plug. If it still does not fit, contact a qualified electrician to install the proper outlet. Do not change the plug in any way.

SAVE THESE INSTRUCTIONS

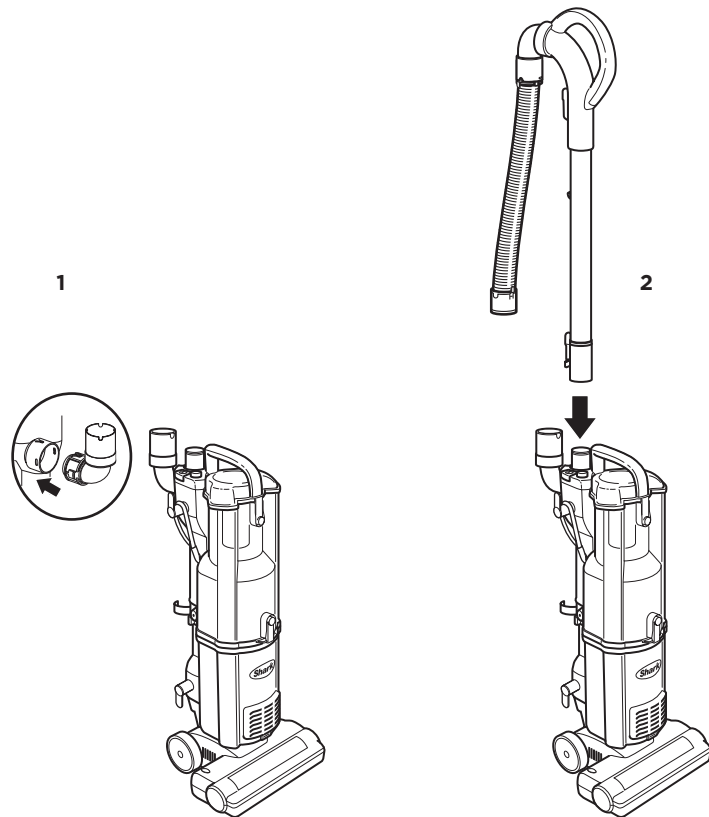

1. Insert the **Hose Connector** into the opening on the back of the **Vacuum Body**.
2. Insert the **Handle with Wand** onto the top of the vacuum until it clicks into place.
3. Insert the **Hose** into the hose connector on the back of the vacuum body, pressing it in until it clicks into place.
4. Attach **Accessory Clip** on back of vacuum body:
 - a. Insert clip tabs into slots.
 - b. Swing clip onto handle post.
 - c. Attach accessories to top and bottom of accessory clip.

For proper operation, ensure all parts are firmly clicked into place.

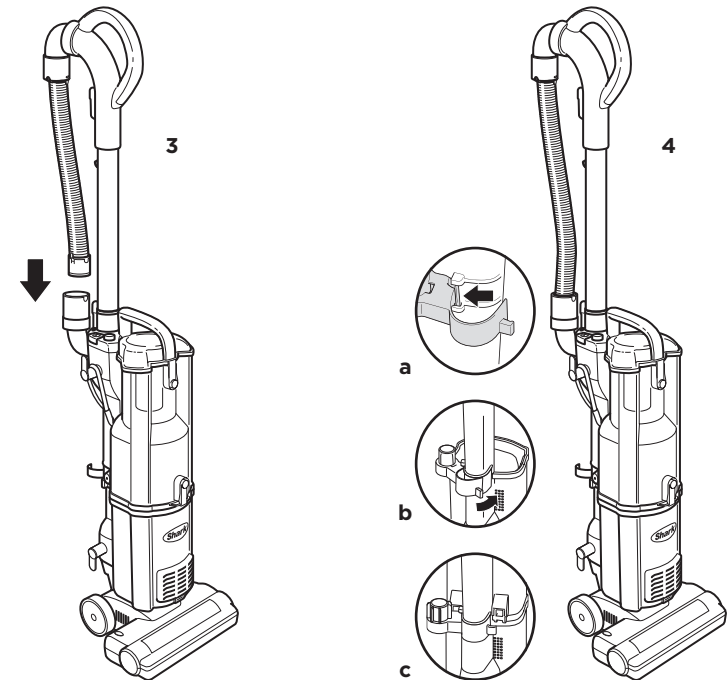

NOTE: The hose must be securely attached to the wand to enable suction to reach the floor nozzle.

NOTE: There are a variety of accessories that are compatible with this vacuum series. The top flap of your box shows the select accessories that are included with your model. For additional accessories, visit sharkaccessories.com

WHOLE-HOME CLEANING

SETTINGS

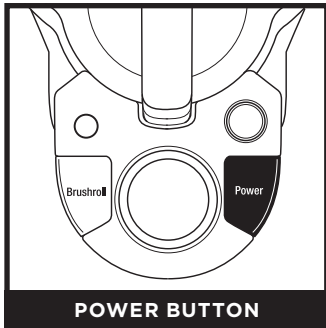

Press the **Power** button on the top of the vacuum body.

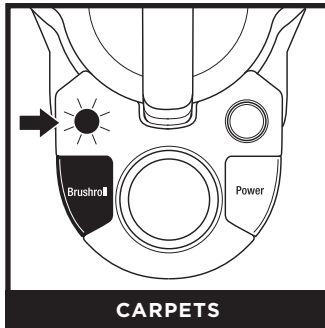

Press the **Brushroll** button on the top of the vacuum body to use the brushroll to clean carpets. Indicator light will turn green.

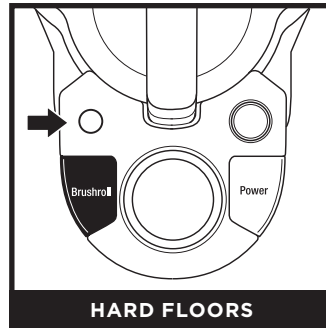

Press the **Brushroll** button again to shut off the brushroll to clean bare floors. Indicator light will turn off.

NOTE: Brushroll will not spin unless handle is tilted back.

BRUSHROLL INDICATOR LIGHT

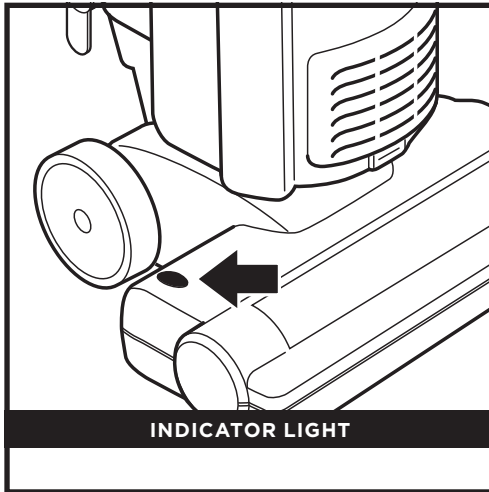

WHAT DOES THE BRUSHROLL INDICATOR LIGHT MEAN?

Solid Green: The brushroll is spinning and working as it should.

Solid Red: There is a jam in the brushroll area. Turn your vacuum off and remove any blockages in the nozzle.

No Light: The brushroll is off.

NOTE: For deep carpet cleaning per ASTM F608 (embedded dirt in carpets), press the **Brushroll** button.

WHOLE-HOME CLEANING

CLEANING MODES

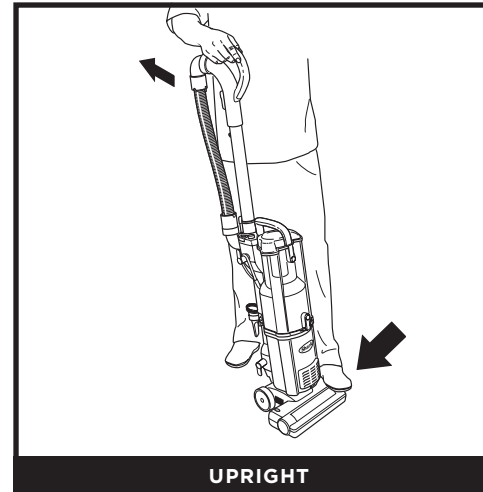

To engage brushroll, turn power on, press the brushroll button, then place foot on floor nozzle and tilt handle back.



Press the **Handle Release** button to remove the handle from the wand. Attach a cleaning tool to the end of the handle.

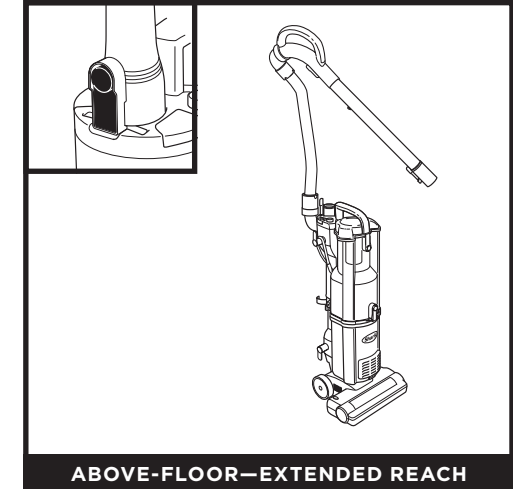

Press the **Wand Release** button to remove the wand from the vacuum body. Attach a cleaning tool to the end of the wand.

NOTE: All accessories are compatible with both the wand and the handle.

EMPTYING THE DUST CUP

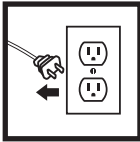

IMPORTANT: Unplug the power cord before performing any maintenance.

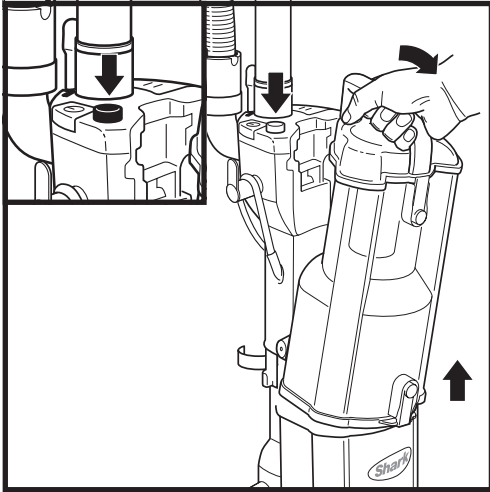

To remove **Dust Cup**, press the **Dust Cup Release** button next to the power button. Tilt dust cup, then lift to remove.

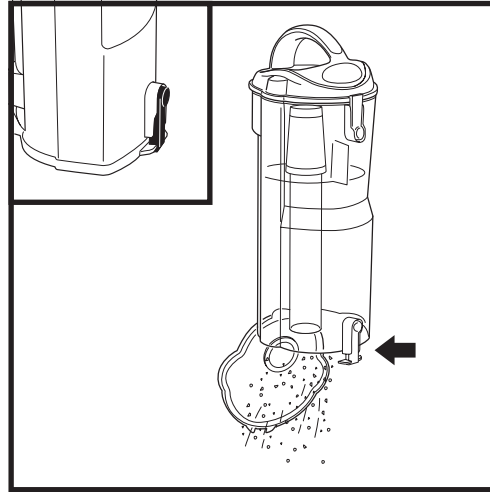

To empty debris into trash, press lower release button and bottom of dust cup will drop open.

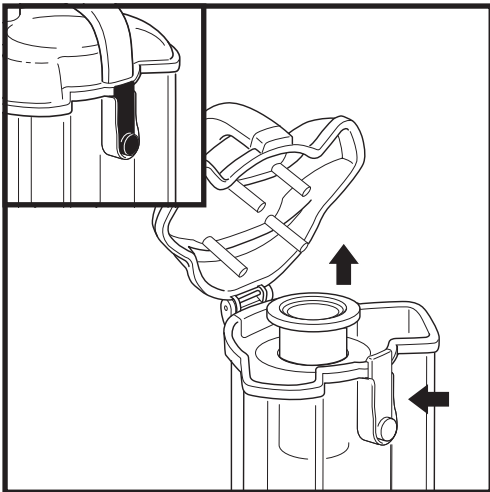

To remove collected debris from **Lint Screen**, press top release button and lift handle to open. Lift out lint screen and gently brush it to clean.

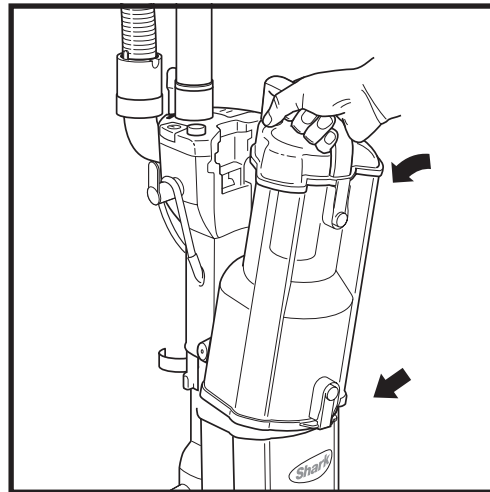

To reinstall, place bottom of dust cup into pod and then tilt until it clicks into place.

CLEANING AND REPLACING THE FILTERS

CLEANING FILTERS

Regularly clean and replace your filters to keep your vacuum's suction power optimal.

To clean filters, rinse with cold water **ONLY** to prevent damage from cleaning chemicals. Allow all filters to air-dry for at least 24 hours before reinstalling them to prevent liquid from being drawn into electric parts.

IMPORTANT: DO NOT use soap when cleaning the filters.

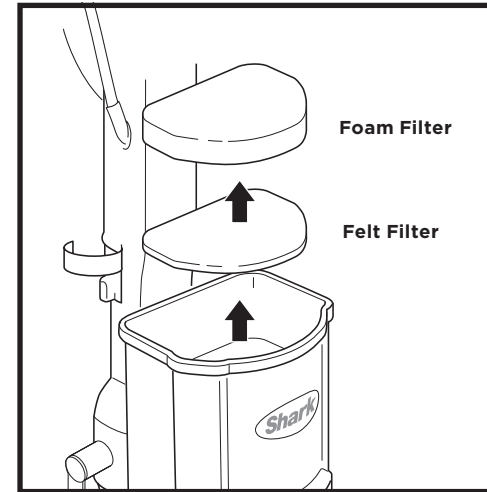

Pre-Motor (foam and felt): With the dust cup removed, take out the **Foam and Felt Filters**.

CLEAN PRE-MOTOR FILTERS EVERY MONTH.

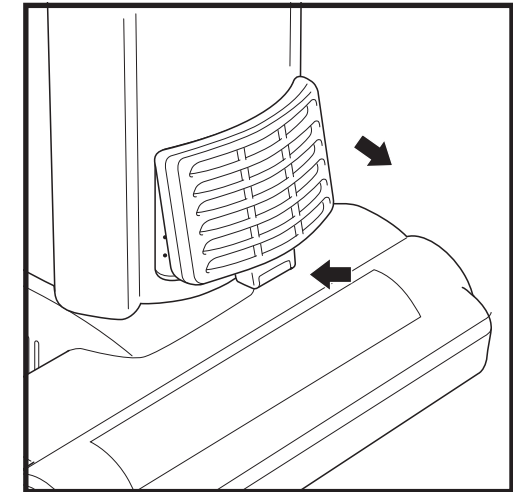

Post-Motor (HEPA): To access the **HEPA Filter**, press the tab, tilt the **Filter Cover**, and lift it away from the vacuum. Remove the HEPA filter.

CLEAN HEPA FILTER EVERY YEAR.

REPLACING FILTERS

Follow the previous instructions for removing filters. The pre-motor filters should be replaced every 2.5 years. The post-motor HEPA filter should be replaced every 3 years.

Replacement Pre-Motor Foam & Felt Filter Kit
XFF80

Replacement HEPA Filter
XHF80

NOTE: To order replacement parts and filters, visit sharkaccessories.com.

CLEANING THE BRUSHROLL

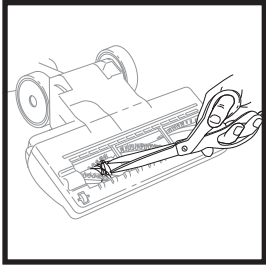

1. Place vacuum flat on the floor and turn it over to access brushroll.
2. Remove any blockages or buildup from the airways in the nozzle. With scissors, carefully cut away any fibers, hair, or string wrapped around the brushroll. Avoid damaging or cutting the bristles.

CHECKING FOR BLOCKAGES

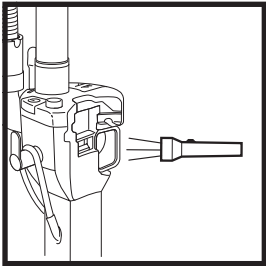

Remove dust cup. Check air duct behind dust cup for clogs.

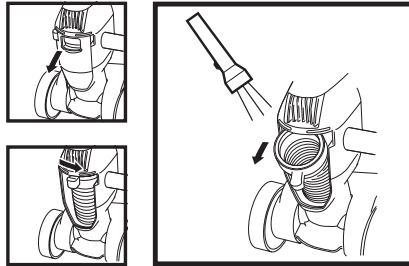

Remove the **Hose Access Door** by pulling it down from the top. Slide the knob to the center and pull out the hose. Clear away any obstructions.

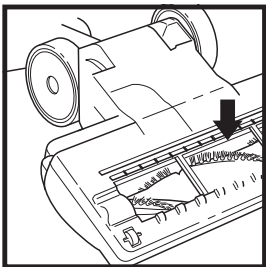

Check opening behind the brushroll for clogs and clear away any obstructions.

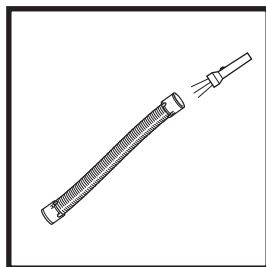

Remove hose from both the vacuum body and the handle. Inspect the length of the hose for clogs.

TROUBLESHOOTING

PROBLEM	POSSIBLE REASONS & SOLUTIONS
Vacuum will not run.	<p>Check to see if the vacuum is plugged in properly.</p> <p>Check the circuit breaker/fuse.</p> <p>Check the Power button.</p>
Vacuum is not picking up dirt. Airflow is restricted. No suction or light suction.	<p>Check filters to see if they need cleaning. Follow instructions for rinsing and drying the filters before reinserting them back into the vacuum.</p> <p>Dust cup may be full; empty dust cup.</p> <p>Check hose and hose connections for blockages; clear blockages if required.</p> <p>If dust cup is empty, and attachment inlets are clear, check for other blockages. See Checking for Blockages for instructions.</p>
Brushroll does not turn on.	<p>Press the Brushroll button.</p> <p>The brushroll indicator light will illuminate green.</p> <p>Place your foot on the floor nozzle and tilt the handle back to engage the brushroll.</p> <p>If the brushroll indicator light on the nozzle is red, see the Checking for Blockages section for more information.</p>
Vacuum turns off on its own, or indicator light flashes red.	<p>This vacuum is equipped with a motor-protective thermostat. If your vacuum overheats, the thermostat will automatically turn the suction motor off. Perform the following steps to restart the thermostat:</p> <ol style="list-style-type: none"> 1. Turn vacuum off and unplug it. 2. Empty dust cup and clean filters. 3. Check for blockages in hose, accessories, and inlet openings. 4. Allow unit to cool for a minimum of 45 minutes. 5. Plug in vacuum and turn it on. <p>Note: If vacuum still does not start, contact Customer Service at: 1-800-798-7398.</p>

ONE (1) YEAR LIMITED WARRANTY

The One (1) Year Limited Warranty applies to purchases made from authorized retailers of **SharkNinja Operating LLC**. Warranty coverage applies to the original owner and to the original product only and is not transferable.

SharkNinja warrants that the unit shall be free from defects in material and workmanship for a period of one (1) year from the date of purchase when it is used under normal household conditions and maintained according to the requirements outlined in the Owner's Guide, subject to the following conditions and exclusions:

What is covered by this warranty?

1. The original unit and/or non-wearable components deemed defective, in SharkNinja's sole discretion, will be repaired or replaced up to one (1) year from the original purchase date.
2. In the event a replacement unit is issued, the warranty coverage ends six (6) months following the receipt date of the replacement unit or the remainder of the existing warranty, whichever is later. SharkNinja reserves the right to replace the unit with one of equal or greater value.

What is not covered by this warranty?

1. Normal wear and tear of wearable parts (such as foam filters, HEPA filters, pads, etc.), which require regular maintenance and/or replacement to ensure the proper functioning of your unit, are not covered by this warranty. Replacement parts are available for purchase at **sharkaccessories.com**.
2. Any unit that has been tampered with or used for commercial purposes.
3. Damage caused by misuse (e.g., vacuuming up water or other liquids), abuse, negligent handling, failure to perform required maintenance (e.g., not cleaning the filters), or damage due to mishandling in transit.
4. Consequential and incidental damages.
5. Defects caused by repair persons not authorized by SharkNinja. These defects include damages caused in the process of shipping, altering, or repairing the SharkNinja product (or any of its parts) when the repair is performed by a repair person not authorized by SharkNinja.
6. Products purchased, used, or operated outside North America.

How to get service

If your appliance fails to operate properly while in use under normal household conditions within the warranty period, visit **sharkclean.com/support** for product care and maintenance self-help. Our Customer Service Specialists are also available at **1-800-798-7398** to assist with product support and warranty service options, including the possibility of upgrading to our VIP warranty service options for select product categories.

SharkNinja will cover the cost for the customer to send in the unit to us for repair or replacement. A fee of \$24.95 (subject to change) will be charged when SharkNinja ships the repaired or replacement unit.



How to initiate a warranty claim

You must call **1-800-798-7398** to initiate a warranty claim. You will need the receipt as proof of purchase. A Customer Service Specialist will provide you with return and packing instruction information.

How state law applies

This warranty gives you specific legal rights, and you also may have other rights that vary from state to state. Some states do not permit the exclusion or limitation of incidental or consequential damages, so the above may not apply to you.

REGISTER YOUR PURCHASE

-  registryyourshark.com
-  Scan QR code using mobile device



RECORD THIS INFORMATION

Model Number: _____

Serial Number: _____

Date of Purchase: _____
(Keep receipt)

Store of Purchase: _____

TECHNICAL SPECIFICATIONS

Voltage: 120V, 60Hz

Watts: 700W

Amps: 5.83A

Benefits of registering your product and creating an account:

- Get easier, faster product support and access to warranty information
- Access troubleshooting and product care instructions
- Be among the first to know about exclusive product promotions

TIP: You can find the model and serial numbers on the QR code label on the bottom of the back of the vacuum body.

PLEASE READ CAREFULLY AND KEEP FOR FUTURE REFERENCE.

This Owner's Guide is designed to help you get a complete understanding of your new Shark Navigator® upright vacuum.

SharkNinja Operating LLC
US: Needham, MA 02494
CAN: Ville St-Laurent, QC H4S 1A7
1-800-798-7398
sharkclean.com

Illustrations may differ from actual product. We are constantly striving to improve our products; therefore the specifications contained herein are subject to change without notice.

For SharkNinja U.S. Patent information, visit sharkninja.com/uspateints

© 2019 SharkNinja Operating LLC. SHARK and SHARK NAVIGATOR are registered trademarks of SharkNinja Operating LLC. NAVIGATOR is a trademark of SharkNinja Operating LLC.

NV100Series_IB_E_REV_Mv2
PRINTED IN CHINA



@sharkcleaning