

Shark®

SharkFlex™ **Corded Ultra-Light**

HV390

Series

INSTRUCTIONS



 sharkclean.com

 1-800-798-7398

THANK YOU

for purchasing the SharkFlex™ Corded Ultra-Light



TIP: You can find the model and serial numbers on the QR code label which is located on the handheld vacuum.

REGISTER YOUR PURCHASE

- registeryourshark.com
- 1-800-798-7398
- Scan QR code using mobile device

RECORD THIS INFORMATION

Model Number: _____
Serial Number: _____
Date of Purchase (Keep receipt): _____
Store of Purchase: _____

TECHNICAL SPECIFICATIONS

Voltage: 120V., 60Hz
Watts: 600W
Amps: 5A

PLEASE READ CAREFULLY AND KEEP FOR FUTURE REFERENCE.

This instruction manual is designed to help you get a complete understanding of your new SharkFlex Corded Ultra-Light.

If you have any questions, please call the Customer Service line at 1-800-798-7398.

CONTENTS

Important Safety Instructions	3
Getting To Know Your SharkFlex™ Corded Ultra-Light	5
Assembling Your Vacuum	7
Using the Motorized Floor Nozzle	8
Using Your Vacuum in Above-Floor Mode	9
Accessories	11
Storage	12
Maintaining Your Vacuum	13
Emptying the Dust Cup	13
Cleaning the Filters	14
Maintaining the Brushroll	15
Maintaining the Soft Roller	16
Checking for Blockages	16
Troubleshooting Guide	17
Warranty	18

IMPORTANT SAFETY INSTRUCTIONS

PLEASE READ CAREFULLY BEFORE USE • FOR HOUSEHOLD USE ONLY

⚠ WARNING

To reduce the risk of injury, fire, electric shock, and property damage resulting from improper use of the appliance, carefully observe the following instructions. This unit contains electrical connections and moving parts that potentially present risk to the user.

THE MOTORIZED FLOOR NOZZLE, WAND, AND HANDHELD VACUUM CONTAIN ELECTRICAL CONNECTIONS:

- These are **NOT** serviceable parts.
- **DO NOT** use to vacuum any liquids.
- **DO NOT** immerse in water when cleaning.
- If handheld vacuum/wand is damaged, discontinue use.

.....

When using an electrical appliance, basic precautions should always be followed, including the following:

- 1** Inspect power cord and plug for any damage before use. **DO NOT** use vacuum cleaner with a damaged cord or plug. Turn off all controls before plugging in or unplugging the vacuum cleaner. Store your vacuum cleaner with the power cord secured around the two cord hooks.
- 2 DO NOT** use outdoors or on wet surfaces. Use only on dry surfaces.
- 3** Brush may start unexpectedly. Unplug from electrical outlet when not in use and before cleaning or servicing.
- 4** If vacuum cleaner is not working as it should, or has been dropped, damaged, left outdoors, or immersed in water, return it to SharkNinja Operating LLC for examination, repair, or adjustment.
- 5 DO NOT** pull or carry vacuum cleaner by the cord or use the cord as a handle.
- 6 DO NOT** unplug by pulling on cord. Grasp the plug, **NOT** the cord.

- 7 DO NOT** handle plug or vacuum cleaner with wet hands.
 - 8 DO NOT** run the vacuum cleaner over the power cord, close a door on the cord, or pull the cord around sharp corners.
 - 9** The use of an extension cord is **NOT** recommended.
 - 10 DO NOT** leave vacuum cleaner unattended when plugged in.
 - 11** Keep cord away from heated surfaces.
 - 12 ALWAYS** turn off this appliance before connecting or disconnecting motorized nozzle.
- ### GENERAL USE
- 13** Use only as described in this manual.
 - 14** Keep your work area well lit.
 - 15** Keep the vacuum cleaner moving over the carpet surface at all times to avoid damaging the carpet fibers.
 - 16 DO NOT** place vacuum cleaner on unstable surfaces such as chairs or tables.
 - 17 DO NOT** put any objects into openings. **DO NOT** use with any opening blocked; keep free of dust, lint, hair, and anything that may reduce airflow.
 - 18 DO NOT** allow young children to operate the appliance or use as a toy. Close supervision is necessary when any appliance is used near children.
 - 19 DO NOT** use without Soft Roller, dust cup, and all filters in place.

SAVE THESE INSTRUCTIONS

- 20 DO NOT** use if airflow is restricted; if the air paths or the motorized floor nozzle become blocked, turn the vacuum cleaner off and unplug from electrical outlet. Remove all obstructions before you turn on the unit again.
- 21** Keep hair, loose clothing, fingers, and all parts of body away from openings and moving parts.
- 22** Only use manufacturer's recommended attachments.

DUST CUP/FILTERS/ACCESSORIES

Before turning on the vacuum:

- 23** Make sure that all filters and Soft Roller are thoroughly dry after routine cleaning.
- 24** Make sure Soft Roller, dust cup, and all filters are in place after routine maintenance.
- 25** Make sure accessories are free of blockages and keep openings away from face and body.
- 26** Use only Shark® brand filters and accessories. Using other brands will void warranty.

GENERAL CLEANING

- 27 DO NOT** vacuum up hard or sharp objects that could damage the vacuum cleaner such as glass, nails, screws, or coins.

- 28 DO NOT** vacuum up drywall dust, fireplace ash, or embers. **DO NOT** use as an attachment to power tools for dust collection.
- 29 DO NOT** vacuum up smoking or burning objects such as hot coals, cigarette butts, or matches.
- 30 DO NOT** vacuum up flammable or combustible materials (e.g., lighter fluid, gasoline, or kerosene) or use vacuum in areas where they may be present.
- 31 DO NOT** vacuum up toxic solutions (e.g., chlorine bleach, ammonia, or drain cleaner).
- 32 DO NOT** use in an enclosed space where vapors are present from paint, paint thinner, moth-proofing substances, flammable dust, or other explosive or toxic materials.
- 33 DO NOT** vacuum up any liquids.
- 34 DO NOT** immerse vacuum cleaner in water or other liquids.
- 35** Use extra care when cleaning on stairs.

.....

POLARIZED PLUG

To reduce the risk of electric shock, this vacuum cleaner has a polarized plug (one blade is wider than the other). As a safety feature, this plug will fit into a polarized outlet only one way. If the plug does not fit fully into the outlet, reverse the plug. If it still does not fit, contact a qualified electrician. **DO NOT** force into outlet or try to modify to fit.

GETTING TO KNOW YOUR SHARKFLEX™ CORDED ULTRA-LIGHT

WELCOME!

Congratulations on your purchase. Use this instruction manual to learn about your new vacuum's great features. From assembly to use to maintenance, you will find it all in here.

MAIN UNIT

- A** Power/Selector Switch
- B** Handheld Vacuum
- C** Dust Cup Release
- D** Dust Cup Empty Button
- E** MultiFLEX™ Wand Release
- F** MultiFLEX Storage Carry Handle
- G** MultiFLEX Lock Release Button
- H** Upper Cord Wrap Hook
- I** MultiFLEX Wand
- J** Lower Wand Release Pedal
- K** Motorized Floor Nozzle
- L** Lower Cord Wrap Hook
- M** Brushroll Garage Release Buttons
- N** Headlights

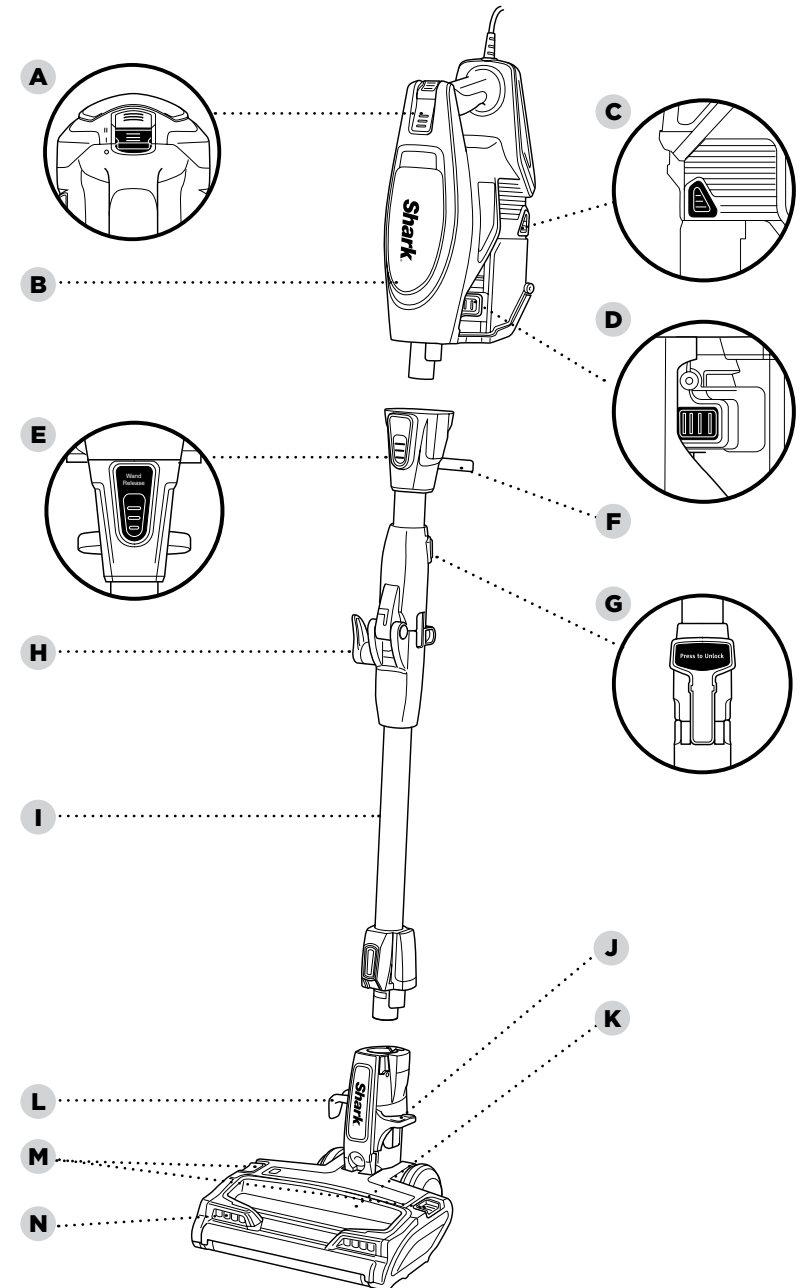

ASSEMBLING YOUR VACUUM

⚠ WARNING: This vacuum does not stand up on its own. Using the unit when it lacks stability may result in personal injury. To place in MultiFLEX™ Storage mode, press the MultiFLEX Lock Release Button and gently fold the handheld vacuum forward toward the floor nozzle.

NOTE: Before vacuuming your delicate area rugs or carpet, refer to the manufacturer's recommended cleaning instructions.

WHAT DOES THE BRUSHROLL INDICATOR LIGHT MEAN?

Solid Green

The brushrolls are on and working as they should.

Solid Red

There is a jam in the brushroll area. Turn your vacuum off and remove the blockage.

No Light

The brushrolls are not spinning.

DID YOU KNOW?

The motorized floor nozzle has LED headlights that illuminate the floor surface being cleaned. The lights turn on automatically in either speed setting.

STEP 1

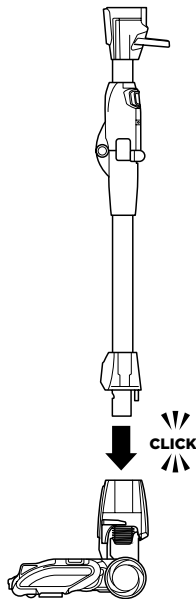

- 1 Insert the wand into the motorized floor nozzle connector, pressing it in until it clicks securely into place.

STEP 2

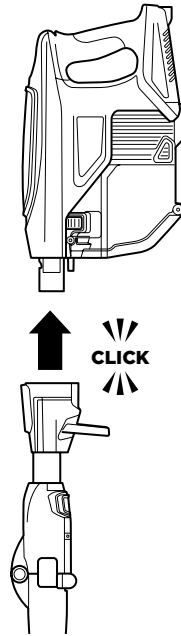

- 2 Insert the handheld vacuum into the top of the nozzle, pressing it in until it clicks securely into place.

USING THE MOTORIZED FLOOR NOZZLE

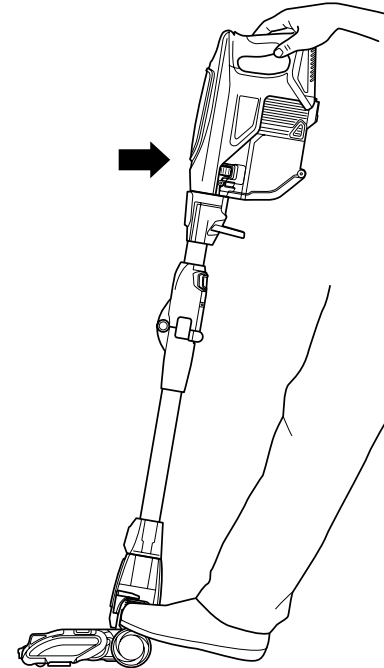

- 1 Slide the Power/Selector Switch to one of the 3 settings:

Setting 0: Turns off power.

Setting I: For cleaning bare floors and area rugs.

Setting II: For cleaning high pile carpets.

To start cleaning, recline wand to activate brushrolls.

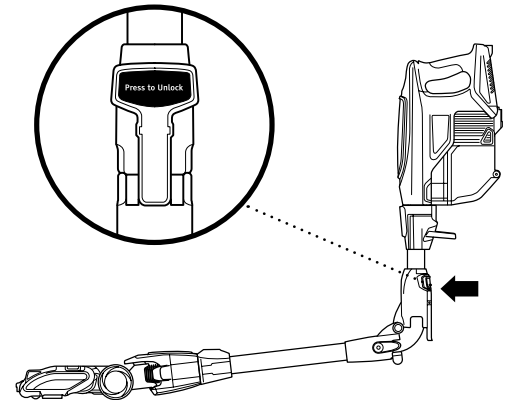

USING THE MULTIFLEX™ WAND

To easily access hard-to-reach areas under furniture, press the MultiFLEX Lock Release Button to position the wand to a lower angle.

USING YOUR VACUUM IN ABOVE-FLOOR MODE

NOTE: Both power settings provide the same suction power.

TIP: You can attach the handheld vacuum directly to the motorized floor nozzle for convenient stair cleaning.

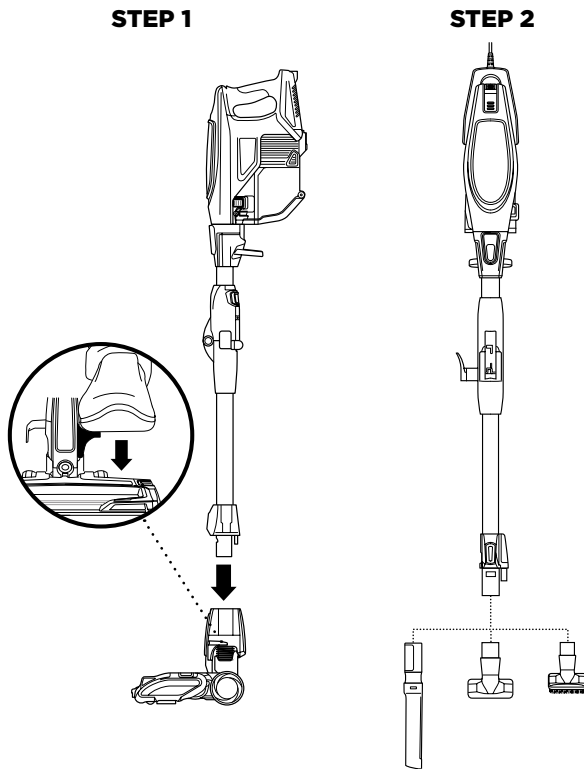

For Long-Reach Cleaning:

- 1 Stand the vacuum upright. Step on the foot pedal and pull the wand up to disconnect it from the motorized floor nozzle.
- 2 Attach desired cleaning accessory to the wand. Press MultifLEX™ button to vacuum with wand at an angle.

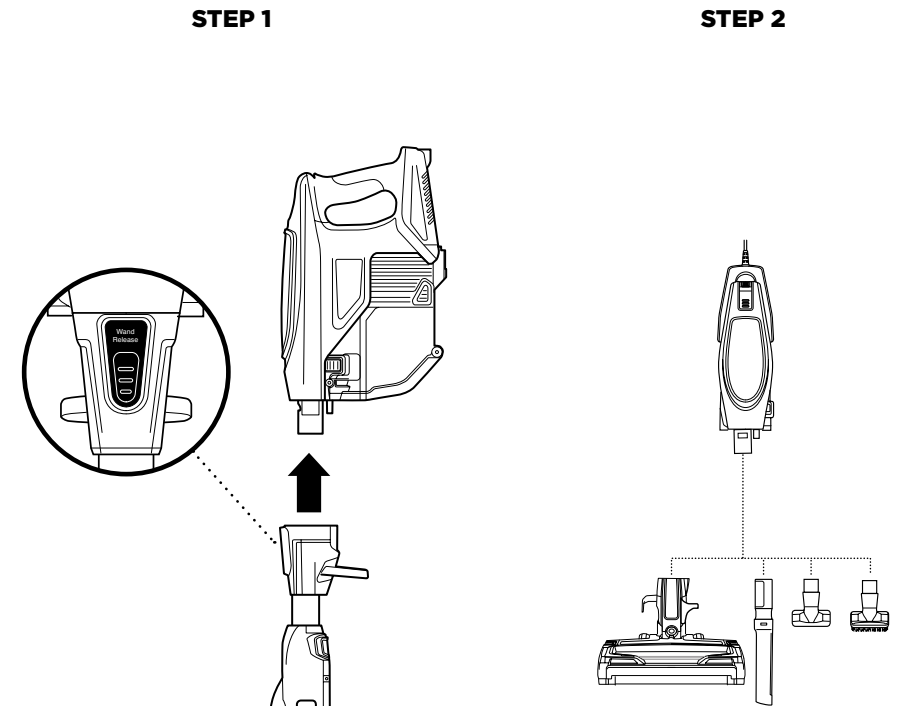

For Short-Reach Cleaning:

- 1 Press the Wand Release button on the top of the wand to disconnect it from the handheld vacuum.
- 2 Attach desired cleaning accessory or motorized floor nozzle to the handheld vacuum.

ACCESSORIES

There are a variety of accessories that are compatible with this vacuum series.

The Quick Start Guide shows the select accessories that are included with your model.

To purchase additional accessories, visit sharkaccessories.com

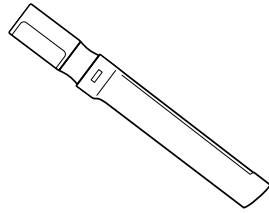

A 12" Crevice Tool

Clean tight spaces or reach baseboards and ceilings with this slim crevice tool.

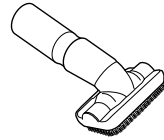

B Dusting Brush

Great for dusting a multitude of surfaces such as shelves, baseboards, window frames, and more.

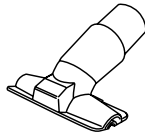

C Upholstery Tool

Perfect for large-particle pickup, dusting, and removing pet hair and lint from furniture and other upholstered surfaces.

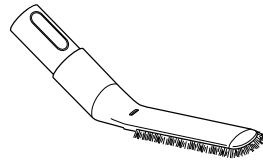

D Anti-Allergen Dust Brush

Nylon fiber bristles specially designed for removing fine dust and allergen particles from the most delicate surfaces.

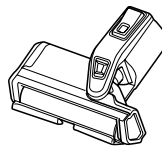

E Deep-Cleaning Motorized Pet Tool

Motorized compact brush powerful enough to remove deeply embedded allergens, dirt, and hair from multiple surfaces.

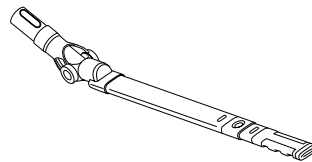

F MultiFLEX™ Under Appliance Wand

Pivoting wand that extends to clean under appliances and on top of furniture.

STORAGE



TIP: The carry handle located below the handheld vacuum can also be used to assist in taking the vacuum in and out of MultiFLEX™ Storage mode.

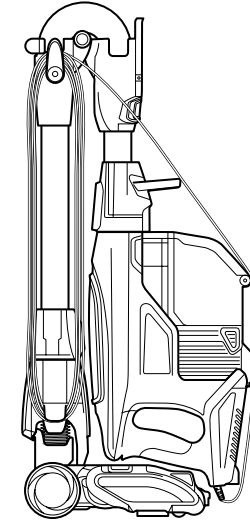

- 1 Press the MultiFLEX Wand Lock Release button and gently fold the handheld vacuum forward toward the floor nozzle until it locks in storage mode. Wrap the power cord around the two cord hooks. Use the handle to carry the vacuum to its storage location.

To take the vacuum out of storage mode, press the MultiFLEX Wand Lock Release button while lifting up the handheld vacuum. When straightened, the wand will lock in place.

MAINTAINING YOUR VACUUM

⚠ WARNING: To reduce the risk of shock and unintended operation, turn off power and unplug unit before servicing.

⚠ WARNING: Hand wash filters only with water to prevent damage from cleaning chemicals. Allow ALL filters to air-dry completely before replacing them in the vacuum to prevent liquid from being drawn into electric parts.

★ IMPORTANT: Clean the dust screen inside the dust cup as required.

NOTE: Empty dust cup when debris reaches the MAX fill line.

RECOMMENDED FILTER CLEANING SCHEDULE:

Pre-Motor Filter Kit
(Foam & Felt)
461FFJV390
Clean once a month.

Post-Motor Filter
464FFJV390
Clean every 9 months.

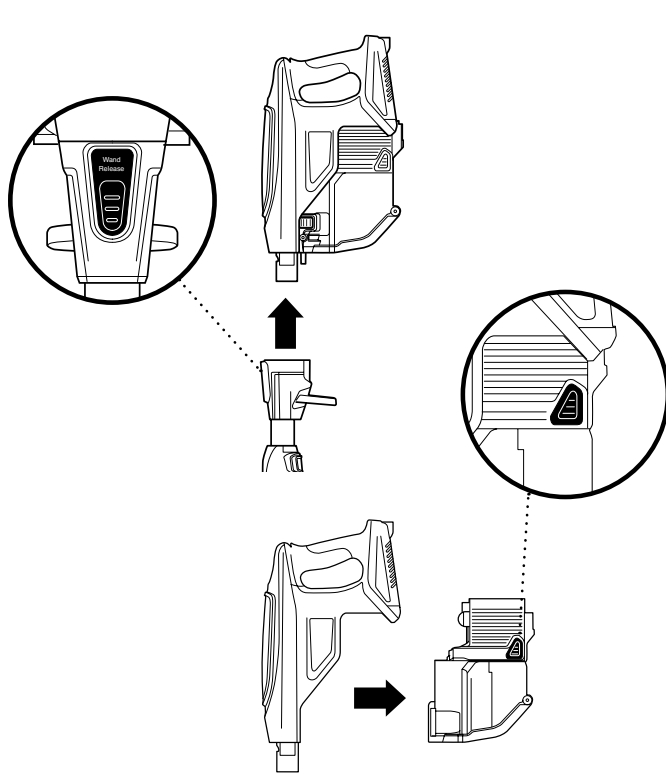

EMPTYING THE DUST CUP

- 1 Disconnect the handheld vacuum by pressing the Wand Release button on the top of the wand.
To remove the dust cup from the handheld vacuum, squeeze the two Dust Cup Release buttons on both sides of the base at the same time, then pull out the dust cup.

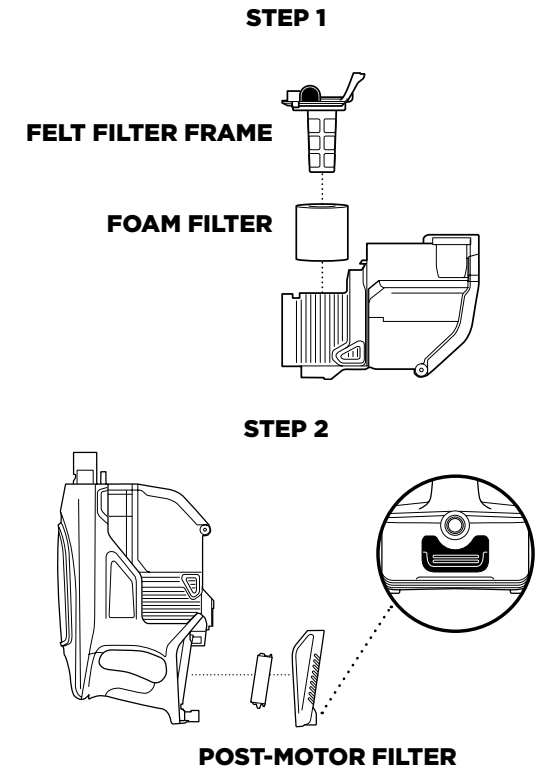
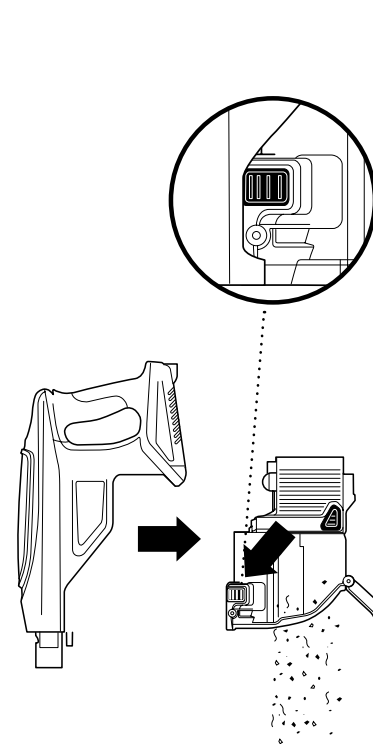

CLEANING THE FILTERS

- 2 Hold dust cup over a trash bin and press the Empty button on the front of the dust cup. The bottom lid will open, allowing the debris to fall out.
 - 3 Once dust cup is empty, close the bottom lid and insert dust cup back into handheld vacuum, pressing it in until it clicks into place.
- 1 Access the pre-motor filter by removing the dust cup from the vacuum. Separate foam filter from felt filter frame and rinse them with water. **DO NOT** use soap. Tap loose dirt off filters as needed. Allow filters to air-dry completely, then reinsert them and reattach the dust cup to the vacuum.
 - 2 Access the Post-Motor filter under the handle. Remove the filter and rinse it with water. **DO NOT** use soap.

MAINTAINING YOUR VACUUM - CONT.

⚠ WARNING: To reduce the risk of shock and unintended operation, turn off power and unplug unit before servicing.

⚠ WARNING: When cleaning brushroll, be sure to not cut anything other than hair, string, fibers, or other debris.

💡 TIP: If nozzle headlights are flashing, then the brushroll garage is not completely closed. Ensure the garage is completely closed by pressing down firmly on both sides.

NOTE: Heavy usage over time may require minimal upkeep in order to maintain your vacuum's appearance.

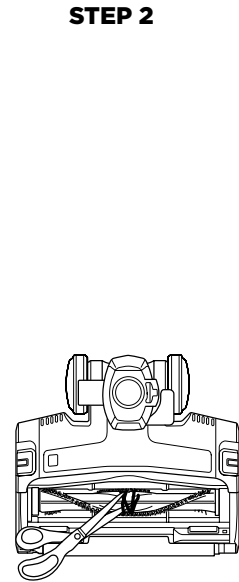
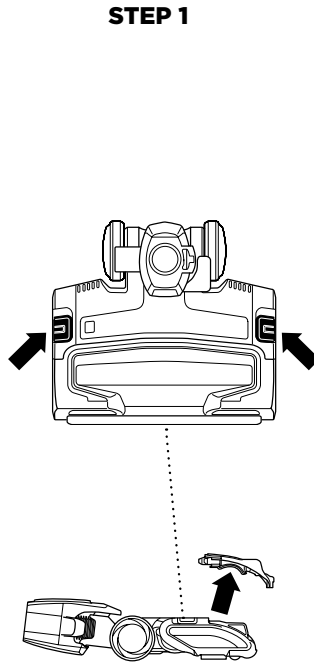

MAINTAINING THE BRUSHROLL

- 1 Open the brushroll garage by sliding both release buttons away from you, toward the back of the nozzle, then lifting off the lid. Remove any string, hair, or debris that may be wrapped around the brushroll by running scissors or the lower corner of the lid along the guide on the brushroll.
- 2 Press down on both sides of the brushroll garage lid until it clicks into place.

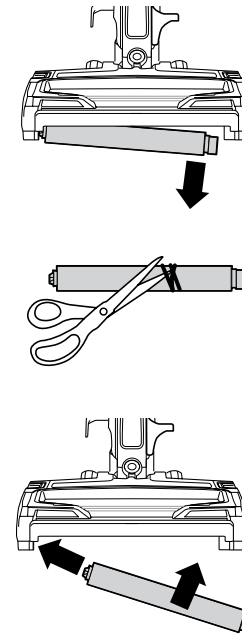

MAINTAINING THE SOFT ROLLER

- 1 Open the brushroll garage by sliding both release buttons away from you, toward the back of the nozzle, then lifting off the lid. Lift out the Soft Roller by the tab on the right side. Clean off any string, carpet fibers, or hair that may be wrapped around the Soft Roller. Remove debris from the roller housing.
- 2 Wash the Soft Roller as needed, using only water. Air-dry completely for at least 24 hours before returning it to the brushroll garage.
- 3 Reinsert the Soft Roller by sliding it into the front of the nozzle until it clicks into place. Close the brushroll garage by inserting the tabs on the lid into the slots, then pressing down on both sides of the lid until it clicks into place.

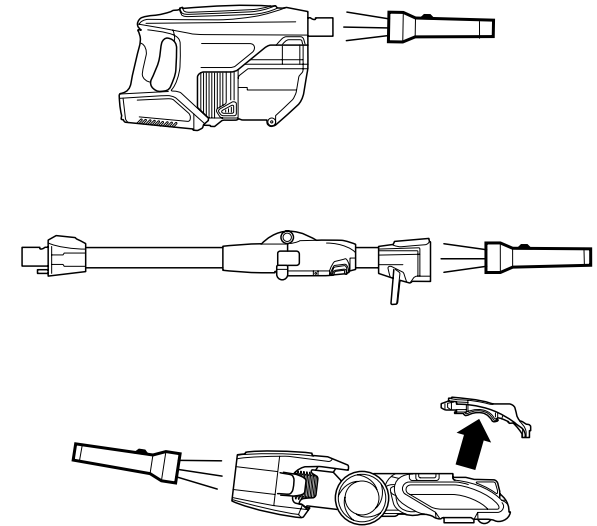

CHECKING FOR BLOCKAGES: HANDHELD, WAND, AND FLOOR NOZZLE

- 1 Remove the wand from the handheld vacuum and check all intake openings on the dust cup.
- 2 Remove the floor nozzle from the wand and check the wand for blockages.
- 3 Tilt neck of floor nozzle back to straighten the airway, then remove blockages.

⚠ WARNING: To reduce the risk of shock and unintended operation, turn off power and unplug unit before servicing.

Vacuum is not picking up debris. No suction or light suction.
(Refer to Maintenance section for more information.)

- Check filters to see if they need cleaning. Follow instructions for rinsing and completely air-drying the filters before reinserting in the vacuum.
- Dust cup may be full; empty dust cup.
- Check floor nozzle for blockages; clear blockages if required.
- Remove any string, carpet fibers, or hair that may be wrapped around the brushroll and Soft Roller or trapped behind the Soft Roller.

Vacuum lifts area rugs.

- Suction is powerful. Take care when vacuuming area rugs or rugs with delicately sewn edges.
- Turn off the unit to disengage the brushroll and restart with the Power/Selector slider switch.

Brushroll/Soft Roller does not spin.

- If Brushroll Indicator Light on the floor nozzle turns red, the brushroll and/or Soft Roller have stopped spinning. Immediately turn off and unplug vacuum and remove blockage before reconnecting and turning vacuum back on.
- If Brushroll Indicator Light on the floor nozzle is green, the blockage has been successfully cleared. If the light is still red, please contact customer service at 1-800-798-7398.
- If nozzle LED headlights are flashing, this means the brushroll garage is not completely closed. Turn off and unplug the vacuum. Ensure the brushroll garage is locked by inserting the tabs on the lid into the slots, then pressing down on both sides of the lid until it clicks into place.

Vacuum turns off on its own.

This vacuum is equipped with a motor-protective thermostat so the vacuum will shut off if it overheats. Should this occur, perform the following steps to restart the motor-protective thermostat:

1. Turn off vacuum and unplug it.
2. Empty dust cup and clean filters (see Maintenance section).
3. Check for blockages in hose, accessories, and inlet openings.
4. Allow unit to cool for a minimum of 45 minutes.
5. Plug in vacuum and turn it on.

Note: If vacuum still does not start, contact Customer Service at 1-800-798-7398.

The 5-Year Limited Warranty applies to purchases made from authorized retailers of **SharkNinja Operating LLC**. Warranty coverage applies to the original owner and to the original product only and is not transferable.

SharkNinja warrants that the unit shall be free from defects in material and workmanship for a period of 5 years from the date of purchase when it is used under normal household conditions and maintained according to the requirements outlined in this instruction manual, subject to the following conditions and exclusions.

What is covered in my warranty?

1. The original unit and/or non-wearable components deemed defective, in SharkNinja's sole discretion, will be repaired or replaced for up to 5 years from the original purchase date.
2. In the rare event that a replacement unit is issued, the warranty coverage ends six months following the receipt date of the replacement unit or the remainder of the existing warranty, whichever is greater. If the unit is replaced, SharkNinja reserves the right to replace the unit with one of equal or greater value.

What is not covered in my warranty?

Our Customer Service/Product Specialists are available to provide all the warranty service options available to you, including the possibility of upgrading to our VIP Warranty Service Options for select product categories.

1. Normal wear and tear of wearable parts such as foam filters, HEPA filters, pads etc., which require regular maintenance and/or replacement to ensure the proper functioning of your unit are not covered by this warranty.
2. Any unit that has been tampered with or used for commercial purposes.
3. SharkNinja will cover the cost for the customer to send in the unit to us for repair or replacement. A fee of \$19.95 for return shipping costs will be charged at the time of return shipment of the repaired or replacement unit.
4. Damage caused by misuse, abuse, or negligent handling, or damage due to mishandling in transit.
5. Consequential and incidental damages.
6. Defects caused by or resulting from damages from shipping or from repairs, service or alteration to the product or any of its parts which have been performed by a repair person not authorized by SharkNinja.
7. Products purchased, used or operated outside of North America.

Problems with your unit/How to get service

If your appliance fails to operate properly while in use under normal household conditions within the warranty period, visit sharkclean.com for product care/maintenance self-help. Our Customer Service and product specialists are also available at 1-800-798-7398 to assist with product support and warranty service options.

How to initiate a warranty claim

You can call 1-800-798-7398 to have a Customer Service specialist assist you. Please note you must call 1-800-798-7398 to initiate a warranty claim. Return and Packing Instruction information will be provided at that time.

For Customer Service hours, visit sharkclean.com

Replacement parts are available for purchase at sharkaccessories.com. For more information on which parts are classified as wearable and non-wearable, please visit sharkclean.com/warranty

This warranty gives you specific legal rights, and you also may have other rights that vary from state to state.

Some states do not permit the exclusion or limitation of incidental or consequential damages, so the above may not apply to you.



SharkNinja Operating LLC
US: Newton, MA 02459
CAN: Ville St-Laurent, QC H4S 1A7
1-800-798-7398
sharkclean.com

Illustrations may differ from actual product. We are constantly striving to improve our products; therefore the specifications contained herein are subject to change without notice.

SHARK is a registered trademark of SharkNinja Operating LLC.

MULTIFLEX and SHARKFLEX are trademarks of SharkNinja Operating LLC.

For SharkNinja U.S. Patent information, visit sharkninja.com/USPatents

© 2017 SharkNinja Operating LLC
HV390_Series_IB_E_170615
PRINTED IN CHINA



@sharkcleaning