

Shark STEAMSPOT™

Scrubbing & Sanitizing Steam Mop

S2000 Series

OWNER'S GUIDE

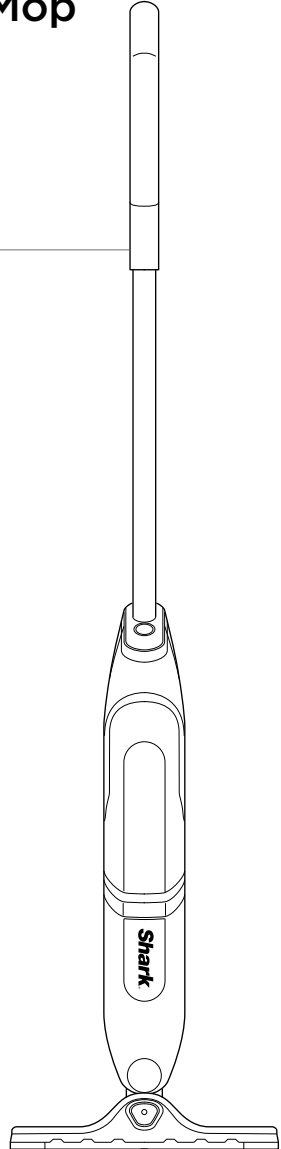

IMPORTANT SAFETY INSTRUCTIONS

PLEASE READ CAREFULLY BEFORE USE • HOUSEHOLD USE ONLY

This steam mop has a polarized plug (one blade is wider than the other). As a safety feature, this plug will fit into a polarized outlet only one way. If the plug does not fit fully into the outlet, reverse the plug. If it still does not fit, contact a qualified electrician. DO NOT attempt to defeat this safety feature. It is not recommended to use an extension cord with this product.

⚠ WARNING

TO REDUCE THE RISK OF FIRE, ELECTRIC SHOCK OR INJURY:

GENERAL WARNINGS

WHEN USING YOUR SHARK® STEAMSPOT, BASIC SAFETY PRECAUTIONS SHOULD ALWAYS BE FOLLOWED, INCLUDING THE FOLLOWING:

1. **DO NOT** leave the steam mop unattended when plugged in. **ALWAYS** unplug the power cord from the electrical outlet when not in use and before servicing.
2. **DO NOT** use with damaged cord or plug. If steam mop is not working as it should or has been dropped, damaged, left outdoors, or dropped into water, return it to SharkNinja Operating LLC for examination and repair. Incorrect reassembly or repair can cause a risk of electrical shock or injury when the steam mop is used.
3. To protect against a risk of electric shock, **DO NOT** immerse the steam mop in water or any other liquids.
4. **DO NOT** handle the plug or steam mop with wet hands or operate it without wearing shoes.
5. **DO NOT** pull or carry by cord, use cord as a handle, close a door on cord, or pull cord around sharp edges or corners. **DO NOT** run steam mop over cord. Keep cord away from heated surfaces.
6. **DO NOT** unplug by pulling on power cord. To unplug, grasp the plug not the power cord. **DO NOT** use extension cords or outlets with inadequate current-carrying capacity.
7. Unplug before servicing.
8. **ALWAYS** make sure the steam mop is UNPLUGGED when not in use.

9. **NEVER** fill the steam mop or attach the mop head when the steam mop is plugged into an electrical outlet. Unplug from the electrical outlet and allow to cool before you fill the mop, or attach or remove the head.
10. When cleaning the exterior of the steam mop, unplug the power cord from the electrical outlet and clean the steam mop with a dry or damp cloth. DO NOT pour water or use alcohol, benzene, or paint thinner on the steam mop.
11. To avoid circuit overload, DO NOT operate another appliance on the same socket (circuit) as the steam mop.
12. To avoid scalding injuries, ALWAYS unplug and allow the steam mop to cool before removing or changing mop heads, accessories, or pads.

USE WARNINGS

13. When in use, **NEVER** turn the steam mop over on its side or direct steam toward people, pets or plants.
14. Use the system only for its intended use.
15. **DO NOT** use for space-heating purposes.
16. **DO NOT** use outdoors.
17. **DO NOT** allow the steam mop to be used by children. Close attention is necessary when used near children, pets, or plants.
18. Use only as described in this owner's guide.
19. Use only manufacturer's recommended accessories.

SAVE THESE INSTRUCTIONS

20. **DO NOT** put any objects into the steam nozzle openings. Discontinue use if the steam nozzle is blocked.
21. **DO NOT** put hands or feet under the steam mop. It gets very hot.
22. Use **ONLY** on flat, horizontal surfaces. **DO NOT** use on walls, counters, or windows.
23. **DO NOT** use on leather, wax-polished furniture, synthetic fabrics, velvet, or other delicate, steam-sensitive materials.
24. **DO NOT** add cleaning solutions, scented perfumes, oils, or any other chemicals to the water used in the steam mop as this may damage it or make it unsafe for use. If you live in a hard-water area, we recommend using distilled water in your steam mop.
25. **NEVER** leave any pads in one spot while using or storing for an extended period, as this may damage your surfaces.
26. You can release the pad after you have unplugged the steam mop and allowed it to cool.
27. Extreme caution should be exercised when using the steam mop to clean stairs.
28. **NEVER** use the steam mop without a pad attached.
29. Keep your work area well lit.
30. Store steam mop indoors in a cool, dry place.
31. Keep hair, loose clothing, fingers, and all parts of body away from openings and moving parts.
32. **DO NOT** carry the steam mop while in use.
33. The steam emitted from the steam mop is very hot and may cause scalding. Please use caution when using the steam mop.
34. **DO NOT** use on unsealed wood or unglazed ceramic floors. On surfaces that have been treated with wax and on some unwaxed floors, the sheen may be removed by the heat and steam action.
35. **ALWAYS** test an isolated area of the surface to be cleaned before proceeding. We also recommend that you check the use and care instructions from the floor manufacturer.
36. **DO NOT** scrub any one area for an extended period.
37. **DO NOT** use the steam mop without attaching a pad and adding water to the water tank. When you use the steam mop for the first time, it might take longer than the normal 30 seconds to start steaming.
38. **DO NOT** use on unsealed wood or unglazed ceramic floors. On surfaces that have been treated with wax and on some unwaxed floors, the sheen may be removed by the heat and steam action. Test an isolated area of the surface to be cleaned before proceeding. Check the use and care instructions from the floor manufacturer.
39. To prolong the life of your steam mop, we recommend using distilled water. Add **ONLY** water to the tank. Chemicals or cleaning solutions (including vinegar) may damage the steam mop and could be unsafe for you and your family.
40. **DO NOT** use to pick up flammable or combustible liquids, such as gasoline, or use in areas where they may be present.
41. The liquid or steam must not be directed towards equipment containing electrical components, such as interior of ovens. Dispose of contents/container with a licensed waste disposal site in accordance with the requirements of the local waste disposal authority.
42. Use only identical replacement parts. Only use parts designated for this product.
43. **DO NOT** allow to be used as a toy.
44. Keep Steam mop away from children.
45. Keep the appliance out of reach of children when it is energized or cooling down.

READ ALL INSTRUCTIONS BEFORE USE

GETTING STARTED

- A** Handle
- B** Pole
- C** Mode Button
- D** Steam Blaster® Trigger
- E** Clean Water Tank
- F** Power Cord
- G** Nozzle Base
- H** Dirt Grip® Pad
- I** Scrub Pad

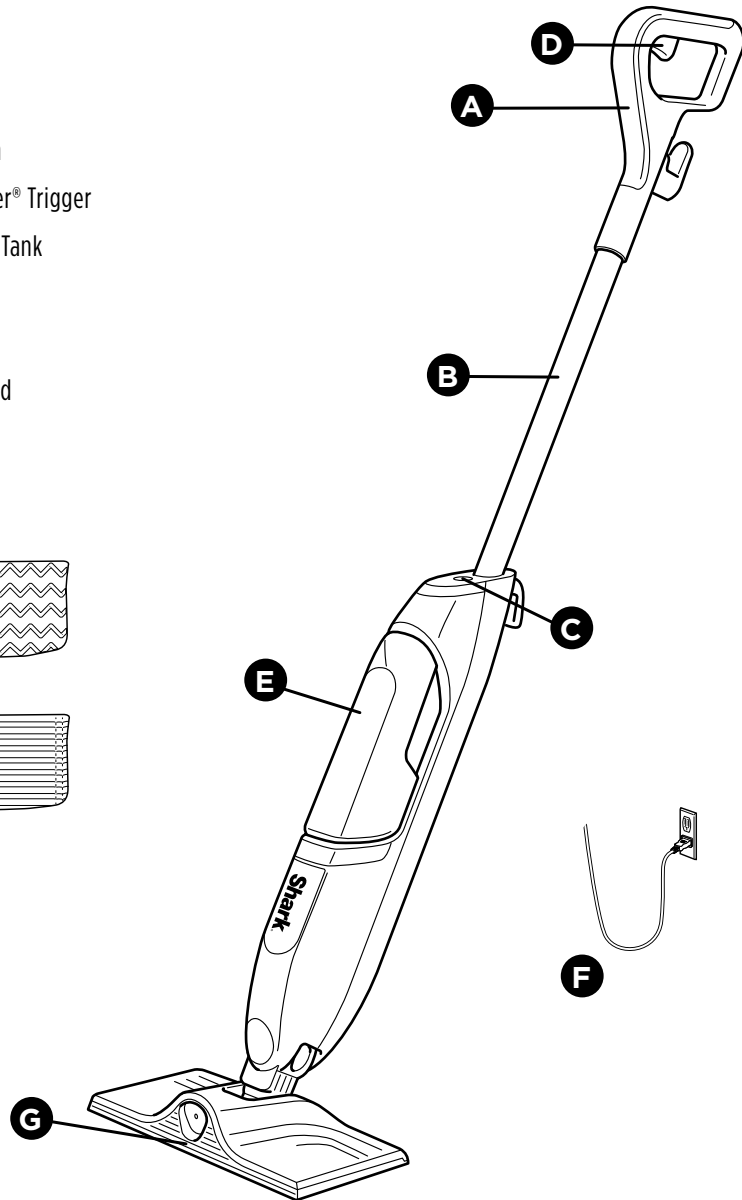
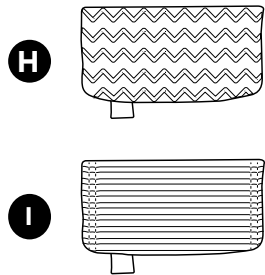

NOTE: Some pad types may not be included based on the model

ASSEMBLING YOUR STEAMSPOT

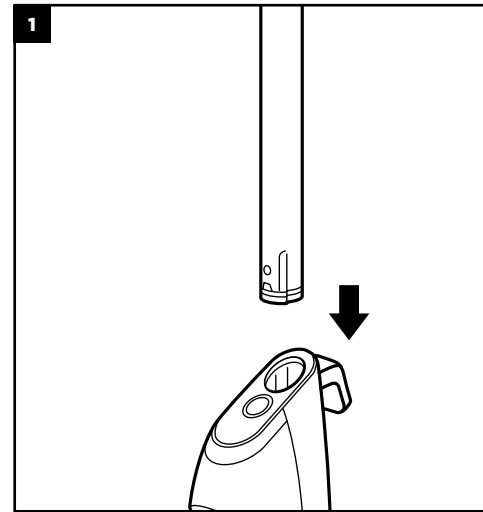

- 1.** Align the pole with the opening in the main body and insert firmly until it clicks into place.

NOTE: Do not leave the steam mop plugged in when not in use

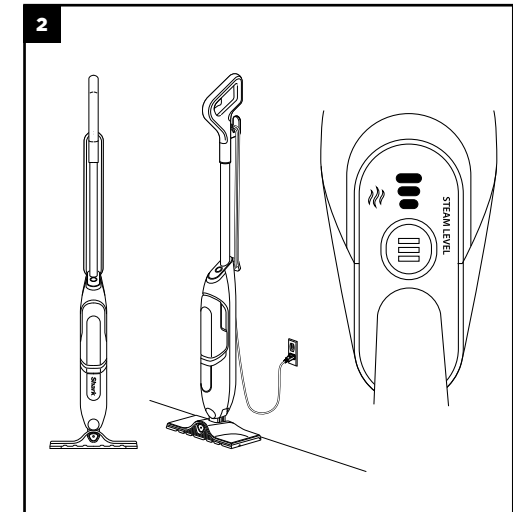

- 2.** Stand the unit upright on a flat surface near a wall outlet and plug in the cord. The LEDs on the main body will illuminate when the cord is plugged in. Make sure all parts are clicked securely into place.

SELECTING A MODE

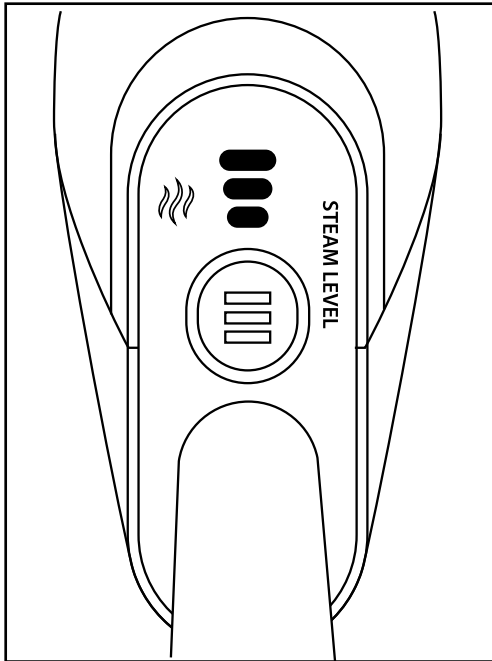

MODES:

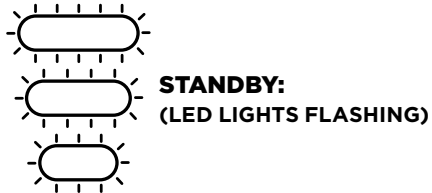

ERROR MESSAGES:
(REFER TO ERROR MESSAGE SECTION)

NOTE: When plugged in, the unit will not release steam until the handle is tilted back and the steam mop is in use.

FILLING THE CLEAN WATER TANK

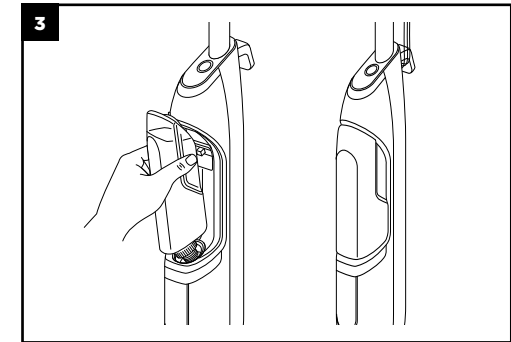
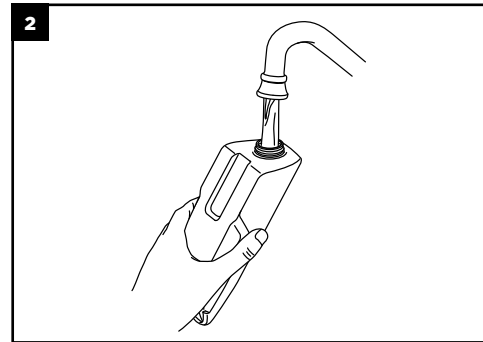
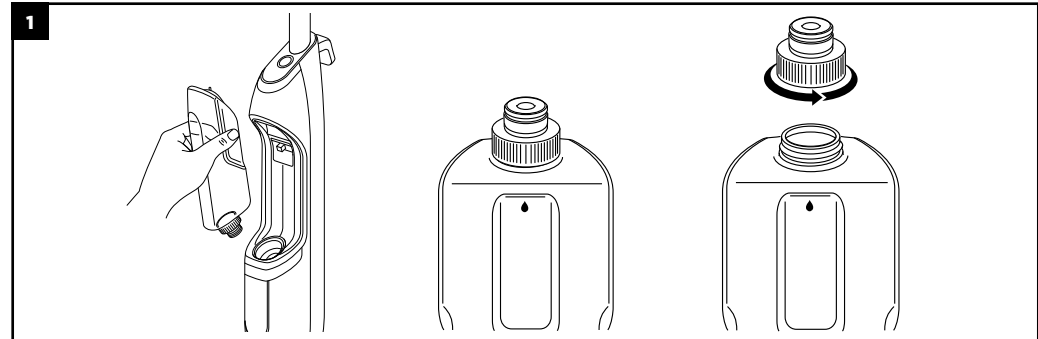

1. Pull out the tank and unscrew the cap.
2. Fill the water tank with **cold or room temperature** water to the WATER fill line.
3. Reattach the cap and rotate it until it is secure. Reinsert the tank until it clicks into place.

NOTE: Without sufficient water supply in the tank, the unit will not produce steam.

NOTE: Adding chemicals or cleaning solutions (including vinegar) may damage the steam mop and could be unsafe for you, your family, and your pets.

TO SANITIZE FLOORS

1. Attach a clean pad to the mop head.
2. Plug in the unit, tilt the handle down towards you, and press the Mode button to select the DEEP mode.
3. Wait at least 20 seconds for the unit to begin producing steam.
4. To ready the unit for sanitization, start cleaning with a forward and backward motion on an appropriate sealed hard floor surface. After three minutes, your unit will be ready to sanitize.
5. Move the floor nozzle slowly and evenly over the area to be sanitized while applying continuous downward pressure. Slowly repeat, making sure to cover the entire area to be sanitized with at least 15 strokes.

*To sanitize floors, be sure to completely follow the product's directions for use. Sanitization studies were conducted under controlled test conditions. Successful sanitization results have been demonstrated in laboratory studies performed using the following species of bacteria: Pseudomonas aeruginosa, Staphylococcus aureus, Escherichia coli, Salmonella enterica (typhi), and Enterobacter aerogenes.

USING YOUR STEAMSPOT

HOW TO USE YOUR STEAMSPOT

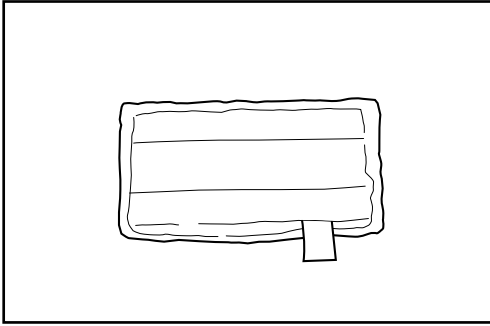

1. Place the pad on the floor with the velcro strips facing up.

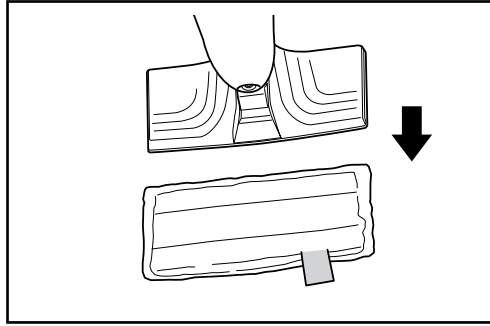

2. Hold the steam mop over the pad, with the back of the nozzle above the tag on the pad. Press down until the pad is attached.

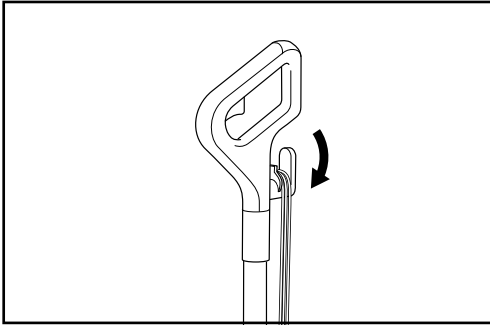

3. Twist the quick-release cord holder to unwrap the power cord. Plug the cord into a wall outlet.

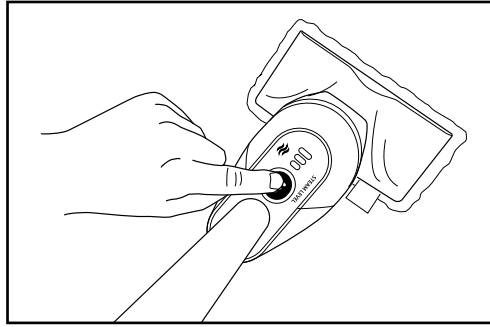

4. Press the Mode button to select the steam level.

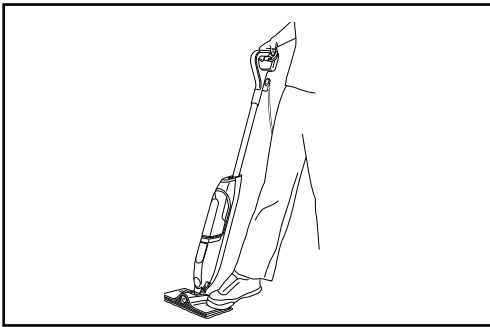

5. Step on the floor nozzle and tilt the handle back to activate the steam flow.

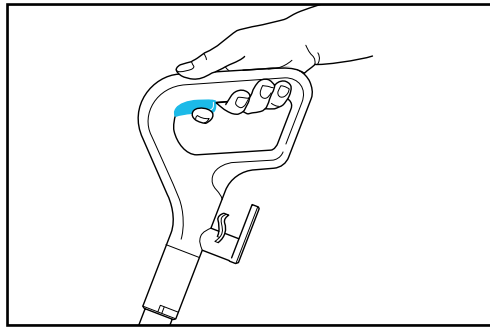

6. To activate the Steam Blaster, press the spray trigger on the handle.

INTELLIGENT STEAM CONTROL®

The Shark® SteamSpot has 3 Intelligent Steam Control modes so you can select the ideal amount of steam to use for each cleaning task. In MEDIUM mode, more steam will be produced than in LOW mode. In HIGH mode, the maximum amount of steam will be produced. Press the Mode button to select the steam level.

MODE	IDEAL FOR THESE SEALED SURFACES	RECOMMENDED USAGE
 LIGHT	Laminate Hardwood Vinyl	Cleaning delicate surfaces. Light cleaning and dusting. Loosening and lifting light dirt.
 NORMAL	Marble Tile Stone	Basic, everyday cleaning. Cleaning large areas. Cleaning moderate and heavy-traffic areas.
 DEEP	Marble Tile Stone	Reaching hard-to-clean surfaces. Tough cleaning and removing stuck-on messes and stains. Deep cleaning heavy-traffic areas. Cutting through heavy dirt and grime and sanitizing* floors.

STEAM BLASTER®:

1. To target tough messes with an extra burst of cleaning power, move the front of the nozzle 2 to 4 inches from the mess (**fig. 3**), then press and hold the spray trigger on the handle as needed. (Hold longer for the toughest messes.)
2. Before scrubbing, wait 5 seconds to let the steam blast penetrate the mess.

Tip: For more difficult messes, wait for 20 seconds or more.

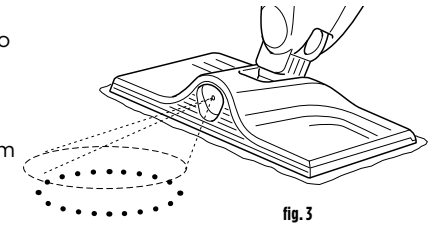

fig. 3

CLEANING TIPS

Move Forward to Clean	For the most effective scrubbing and mopping, make cleaning passes in a forward direction.
Stain Cleaning	Saturate heavily stained areas. Hold the mop in place over a stain for 2 to 3 seconds to saturate it, then run the nozzle over the area multiple times until the stain is fully removed. Repeat if needed. Tough dry stains: Use the Steam Blaster to saturate the stain. Wait 5 seconds before scrubbing. Repeat as needed. Sticky/thick stains: Hold the mop in place over the stain for 10 seconds, then mop.
Mopping	Increase steam level when more saturation is needed.

NOTE: If your floors are cloudy, streaky, or spotty after cleaning, it may be due to accumulated soap or grease residue. See Maintenance section for more information.

MAINTAINING YOUR STEAMSPOT

DISASSEMBLY

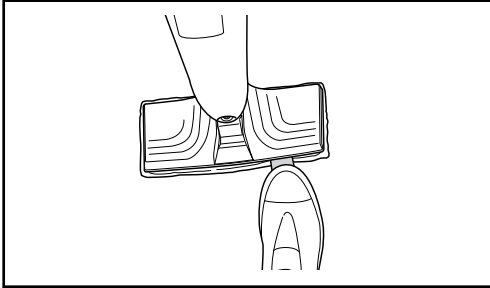

1. With the mop head on the floor, step on the pad tag and lift the steam mop to disengage the pad.

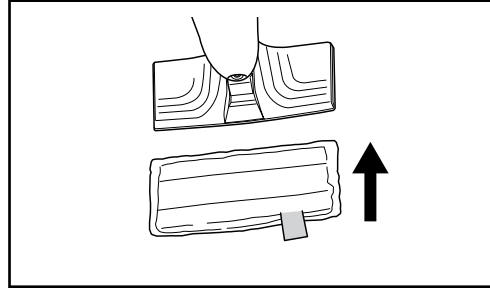

2. Dirty pads can be machine-washed or hand-washed. Allow pads to air-dry completely before reinstalling.

PAD CARE INSTRUCTIONS

Machine-wash pads separately with warm water, using liquid detergent. Do not clean pads in a dishwasher, as some detergents may cause the pads to leave streak marks on the floor. NEVER USE BLEACH, POWDERED DETERGENT, OR FABRIC SOFTENERS. This will damage the pads or leave a coating that will reduce their cleaning performance and absorbency.

The pads should be line-dried or tumble-dried on a low setting, as this will extend the life of the microfiber fabric.

Loose fibers can indicate wearing of the microfiber fabric. DO NOT pull the loose fibers, as this can cause the weave to come undone. Simply trim the loose fibers with scissors.

REPLACEMENT PADS

For best cleaning results, we recommend replacing the pads every 4 months following normal use. As with any fabric, dirt particles, grease, friction, and repeated washing can cause the fibers to break down, and you may notice an increase in effort needed to push or pull the mop.

You can purchase replacement mop pads and other accessories by visiting sharkclean.com

STORAGE

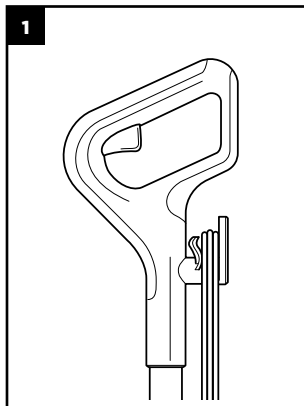

1. When ready to store the steam mop, wrap the power cord securely around the storage clips. Rotate the nozzle 90 degrees and flip it up for compact storage.

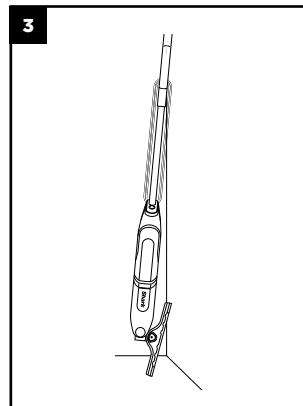
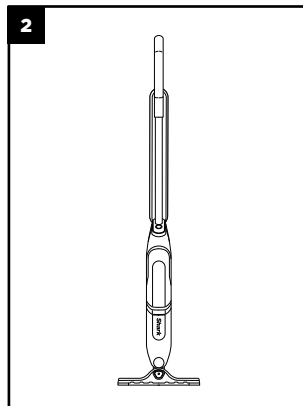

TROUBLESHOOTING

PROBLEM

POSSIBLE REASONS & SOLUTIONS

The steam mop isn't producing any steam.

The steam mop should be securely plugged into an electrical socket. Check your fuse or circuit breaker or try a different socket. Make sure the water tank is full, the unit is plugged in, and the Mode button is illuminated. If the mode lights are off, try a different electrical socket. If the lights are blinking, press the Mode button to select a steam mode. If the lights are illuminated steadily, wait 20 seconds for the unit to warm up. If after following the above steps the steam mop still does not produce any steam, contact Customer Service at 1-800-798-7398 or visit sharkclean.com.

The steam mop is producing intermittent steam.

This is normal. For more consistent steam, select the NORMAL mode. Also make sure the water tank is full.

I can't select a steam mode.

Make sure the steam mop is plugged in and the mode lights are flashing. If your steam mop is producing steam but the mode lights are off, call Customer Service at 1-800-798-7398.

Floors are cloudy, streaky, or spotty after steaming.

The pad might be dirty. Install a clean pad. If you washed the pad with powdered detergent, then it could be damaged and require replacement. Due to accumulated soap or grease residue, the floor may require several cleanings with the steam mop. A more stubborn case may require you to rinse the floor with a mix of one part vinegar and two parts water* (but DO NOT put any cleaning solution into the steam mop's water tank). *Please consult your flooring manufacturer's care and maintenance instructions before applying any cleaning products or solutions.

It's hard to push or pull the mop.

The mop might be hard to push or pull if the pad isn't wet enough. It should get easier to move the mop across the floor after it's been running for a few minutes. An overly dirty pad could also make it harder to push or pull the mop. We recommend using a clean pad.

The steam mop is vibrating or wobbling.

Turn the power OFF and unplug the unit, and wait for the pad to cool. Follow the instructions in the Assembling Your Steam Spot section to reinstall the pad.

The steam mop turns off on its own.

If your steam mop shuts off while in use, it likely needs to cool down. Perform the following steps before you restart cleaning:

1. Turn the steam mop off, unplug it, and remove the pad.
2. Allow the unit to cool for a minimum of 30 minutes.
3. Reinstall the pad. Plug in the steam mop, select a steam mode, and begin cleaning.

Contact Customer Service at 1-800-798-7398 or visit sharkclean.com.

ONE (1) YEAR LIMITED WARRANTY

The One (1) Year Limited Warranty applies to purchases made from authorized retailers of **SharkNinja Operating LLC**. Warranty coverage applies to the original owner and to the original product only and is not transferable.

SharkNinja warrants that the unit shall be free from defects in material and workmanship for a period of one (1) year from the date of purchase when it is used under normal household conditions and maintained according to the requirements outlined in the Owner's Guide, subject to the following conditions and exclusions:

What is covered by this warranty?

1. The original unit and/or non-wearable parts deemed defective, in SharkNinja's sole discretion, will be repaired or replaced up to one (1) year from the original purchase date.
2. In the event a replacement unit is issued, the warranty coverage ends six (6) months following the receipt date of the replacement unit or the remainder of the existing warranty, whichever is later. SharkNinja reserves the right to replace the unit with one of equal or greater value.

What is not covered by this warranty?

1. Normal wear and tear of wearable parts (such as Shark Cleaner, Pad, etc.), which require regular maintenance and/or replacement to ensure the proper functioning of your unit, are not covered by this warranty. Replacement parts are available for purchase at sharkaccessories.com.
2. Any unit that has been tampered with or used for commercial purposes.
3. Damage caused by misuse (e.g., vacuuming up water or other liquids), abuse, negligent handling, failure to perform required maintenance, or damage due to mishandling in transit.
4. Consequential and incidental damages.
5. Defects caused by repair persons not authorized by SharkNinja. These defects include damages caused in the process of shipping, altering, or repairing the SharkNinja product (or any of its parts) when the repair is performed by a repair person not authorized by SharkNinja.
6. Products purchased, used, or operated outside North America.

How to get service

If your appliance fails to operate properly while in use under normal household conditions within the warranty period, visit sharkclean.com/support for product care and maintenance self-help. Our Customer Service Specialists are also available at **1-800-798-7398** to assist with product support and warranty service options, including the possibility of upgrading to our VIP warranty service options for select product categories. So we may better assist you, please register your product online at registeryourshark.com and have the product on hand when you call.

SharkNinja will cover the cost for the customer to send in the unit to us for repair or replacement. A fee of \$24.95 (subject to change) will be charged when SharkNinja ships the repaired or replacement unit.



How to initiate a warranty claim

You must call **1-800-798-7398** to initiate a warranty claim. You will need the receipt as proof of purchase. We also ask that you register your product online at registeryourshark.com and have the product on hand when you call, so we may better assist you. A Customer Service Specialist will provide you with return and packing instruction information.

How state law applies

This warranty gives you specific legal rights, and you also may have other rights that vary from state to state. Some states do not permit the exclusion or limitation of incidental or consequential damages, so the above may not apply to you.

REGISTER YOUR PURCHASE

-  registeryourshark.com
-  Scan QR code using mobile device



Benefits of registering your product and creating an account:

- Get easier, faster product support and access to warranty information
- Access troubleshooting and product care instructions
- Be among the first to know about exclusive product promotions

TIP: You can find the model and serial numbers on the QR code label on the bottom of the back of the steam mop.

RECORD THIS INFORMATION

Model Number: _____

Serial Number: _____

Date of Purchase: _____
(Keep receipt)

Store of Purchase: _____

TECHNICAL SPECIFICATIONS:

Voltage: 120V, 60 Hz

Watts: 1050W (S2000 models) /

1200W (S2001, S2005 models)

Water Capacity: 500ml (16.9oz)

PLEASE READ CAREFULLY AND KEEP FOR FUTURE REFERENCE.

SharkNinja Operating LLC
US: Needham, MA 02494
CAN: Ville St-Laurent, QC H4S 1A7
1-800-798-7398
sharkclean.com

Illustrations may differ from actual product. We are constantly striving to improve our products, therefore the specifications contained herein are subject to change without notice.

This product may be covered by one or more U.S. patents. See sharkninja.com/patents for more information.

© 2024 SharkNinja Operating LLC.
DIRT GRIP, INTELLIGENT STEAM CONTROL, SHARK, and STEAM BLASTER are registered trademarks of SharkNinja Operating LLC.

