

Shark APEX™

DUO clean®

Powered Lift-Away Speed™

QU922Q

Series

INSTRUCTIONS



sharkclean.com



1-800-798-7398

THANK YOU
for purchasing the Shark® APEX™ DuoClean® Powered Lift-Away Speed™



TIP: You can find the model and serial numbers on the QR code label which is located on the back of your unit behind the dust cup.

REGISTER YOUR PURCHASE

- registeryourshark.com
- 1-800-798-7398
- Scan QR code using mobile device

RECORD THIS INFORMATION

Model Number: _____
Serial Number: _____
Date of Purchase (Keep receipt): _____
Store of Purchase: _____

TECHNICAL SPECIFICATIONS

Voltage: 120V., 60Hz
Watts: 900W
Amps: 7.5A

PLEASE READ CAREFULLY AND KEEP FOR FUTURE REFERENCE.

This instruction manual is designed to help you get a complete understanding of your new Shark APEX DuoClean Powered Lift-Away Speed.

If you have any questions, please call the Customer Service line at 1-800-798-7398.

CONTENTS

Important Safety Instructions..... 3

Getting to Know Your Shark® APEX™ DuoClean® Powered Lift-Away Speed™..... 5

Assembling Your Vacuum 7

Using Your Vacuum in Upright Mode 9
What Does the Brushroll Indicator Light Mean? 9

Using Your Vacuum in Above-Floor Mode 11

Using Your Vacuum in Powered Lift-Away Mode..... 13
Powered Lift-Away Cleaning 13
Lift-Away® Cleaning 14

Compatible Accessories..... 15

Maintenance 17
Emptying the Dust Cup..... 17
Cleaning the Filters..... 18
Cleaning the Brushroll 19
Cleaning the Soft Roller..... 20
Checking the Nozzle for Blockages 20

Troubleshooting Guide..... 21

Warranty 22

IMPORTANT SAFETY INSTRUCTIONS

FOR HOUSEHOLD USE ONLY

To reduce the risk of electric shock, this vacuum cleaner has a polarized plug (one blade is wider than the other). As a safety feature, this plug will fit into a polarized outlet only one way. If the plug does not fit fully into the outlet, reverse the plug. If it still does not fit, contact a qualified electrician. Do not force into outlet or try to modify to fit.



WARNING

TO REDUCE THE RISK OF FIRE, ELECTRIC SHOCK OR INJURY:

GENERAL WARNINGS

1. This vacuum cleaner consists of a motorized floor nozzle, wand, and vacuum unit. This device contains electrical connections, electrical wiring, and moving parts that potentially present risk to the user.
2. This appliance is provided with double insulation. Use only identical replacement parts.
3. Carefully observe and follow the instructions provided below to avoid improper use of the appliance.
4. Inspect power cord, plug, vacuum unit, and wand for any damage before use. **DO NOT** use a vacuum cleaner with a damaged power cord, plug, handheld vacuum, or wand.
5. The use of an extension cord is **NOT** recommended.
6. This vacuum cleaner contains no serviceable parts.
7. Use only as described in this manual.
8. **DO NOT** allow the appliance to be used by children. Close supervision is necessary when used near children. This is not a toy.
9. Always turn off the vacuum cleaner before connecting or disconnecting motorized nozzle.
10. **DO NOT** handle plug or vacuum cleaner with wet hands.
11. **DO NOT** use without filters in place.
12. Only use Shark branded filters and accessories. (Failure to do so will also void the warranty).
13. **DO NOT** damage the power cord
 - 13.1. **DO NOT** Pull or carry vacuum cleaner by the cord use the cord as a handle.
 - 13.2. **DO NOT** unplug by pulling on cord. Grasp the plug, not the cord.
 - 13.3. **DO NOT** run the vacuum cleaner over the power cord, close a door on the cord, pull the cord around sharp corners, or leave the cord near heated surfaces.
14. **DO NOT** put any objects into nozzle or accessory openings. **DO NOT** use with any opening blocked; keep free of dust, lint, hair, and anything that may reduce airflow.
15. **DO NOT** use if nozzle or accessory airflow is restricted; if the air paths or the motorized floor nozzle become blocked, turn the vacuum cleaner off and unplug from electrical outlet. Remove all obstructions before you turn on the unit again.
16. Keep nozzle and all vacuum openings away from hair, face, fingers, uncovered feet, or loose clothing.
17. If vacuum cleaner is not working as it should, has been dropped, damaged, left outdoors, or dropped into water, return it to SharkNinja Operating LLC for examination, repair, or adjustment.

SAVE THESE INSTRUCTIONS

READ ALL INSTRUCTIONS BEFORE USE

18. Use extra care when cleaning on stairs.
19. Do not leave the vacuum cleaner unattended while plugged in.
20. Keep the vacuum cleaner moving over the carpet surface at all times to avoid damaging the carpet fibers.
21. **DO NOT** place vacuum cleaner on unstable surfaces such as chairs or tables.
22. Your Shark Vacuum may not be designed to stand up on its own. When taking a break from cleaning, you may need to rest it against of piece of furniture or a wall, or lay it flat on the floor. Using the vacuum for an application where the unit lacks stability may result in personal injury.
23. **DO NOT** use to pick up:
 - 23.1. Liquids
 - 23.2. Large objects
 - 23.3. Hard or sharp objects (glass, nails, screws, coins) as these may damage the appliance.
 - 23.4. Large quantities of dust (Drywall dust, fireplace ash, or embers.) Do not use as an attachment to power tools for dust collection.
 - 23.5. Smoking or burning objects (Hot coals, cigarette butts, or matches).
 - 23.6. Flammable or combustible materials (Lighter fluid, gasoline, or kerosene).
 - 23.7. Toxic materials (Chlorine bleach, ammonia, or drain cleaner).
24. **DO NOT** use in the following areas:
 - 24.1. Poorly lit areas
 - 24.2. Wet or damp surfaces
 - 24.3. Outdoor areas
 - 24.4. Spaces that are enclosure and may contain explosive or toxic fumes or vapors (lighter fluid, gasoline, kerosene, Paint, paint thinners, moth-proofing substances, or flammable dust).
25. Turn off all controls before plugging or unplugging the vacuum.
26. Unplug from electrical outlet when not in use and before any maintenance or cleaning.
27. Do not immerse in water when cleaning.
28. Hand wash with water only to prevent damage from cleaning chemicals.
29. **DO NOT** cut anything but the hair, fibers, or string that is on the brushroll.
30. Allow all filters to dry completely before replacing in the vacuum to prevent liquid from being drawn into electric parts.
31. Make sure that the dust cup and all filters are in place after routine maintenance.
32. Store the vacuum cleaner with power cord secured around the two cord hooks.

GETTING TO KNOW YOUR SHARK® APEX™ DUOCLEAN® POWERED LIFT-AWAY SPEED™

WELCOME!

Congratulations on your purchase. Use this [Owner's Guide](#) to learn about your new vacuum's great features. From assembly to use to maintenance, you will find it all in here.

MAIN UNIT

- A** Surface Selector
- B** Handle Release Button
- C** Power Button
- D** Hose
- E** Hose Clip
- F** Upper Cord Hook
- G** Lift-Away® Button
- H** Wand Release Button
- I** Dust-Cup Release Latch
- J** Lift-Away Pod
- K** Wand
- L** Dust-Cup Empty Latches
- M** Lower Cord Hook
- N** Motorized Floor Nozzle
- O** Brushroll Indicator Light
- P** Headlights
- Q** Brushroll Garage
- R** Soft Roller

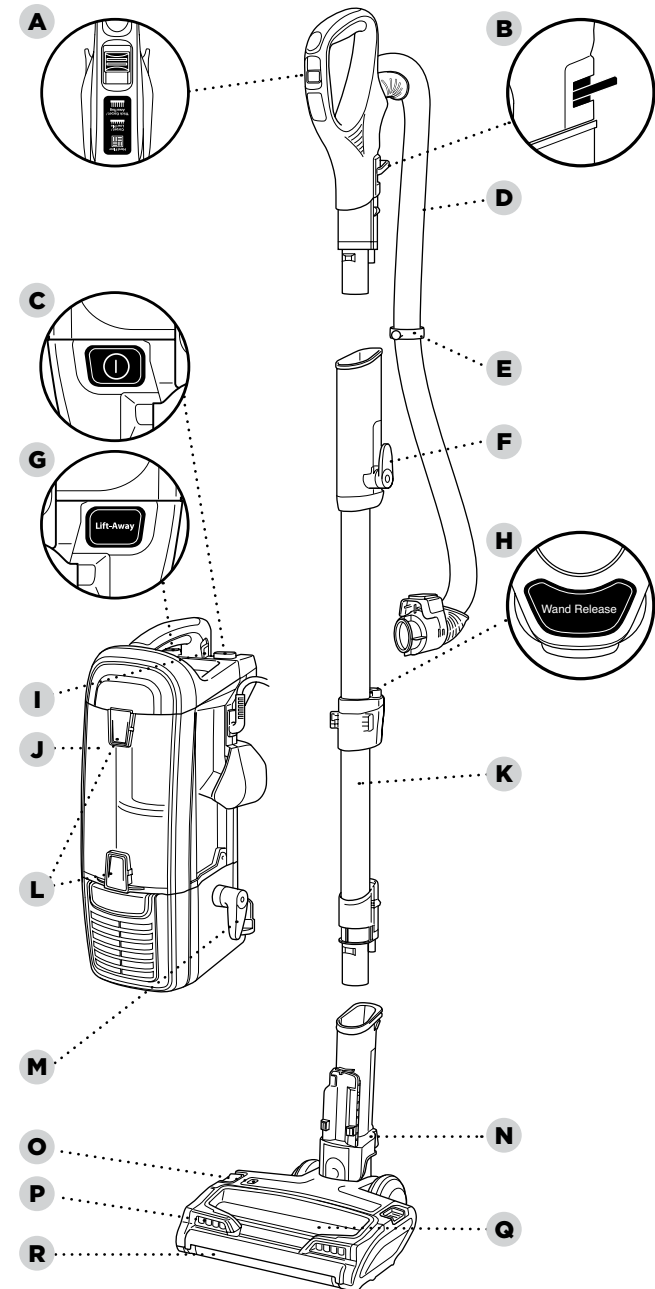

ASSEMBLING YOUR VACUUM

TIP: Push hose clip into back of wand for convenience.

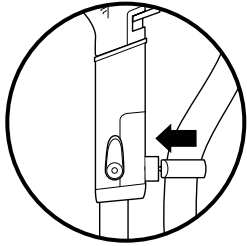

TIP: For quick cord access, rotate upper hook down and remove cord.

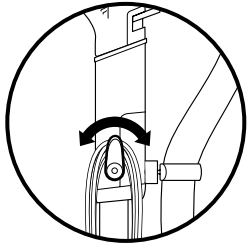

TIP: Use cord clip located on the side of wand to hold cord in place while vacuuming.

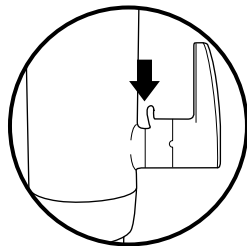

STEP 1

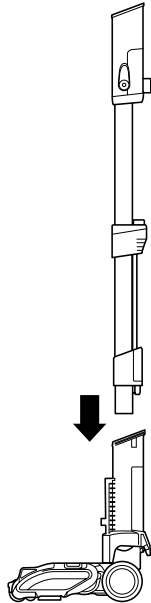

1 Place motorized floor nozzle on floor and insert wand, pressing it in until it clicks securely into place.

STEP 2

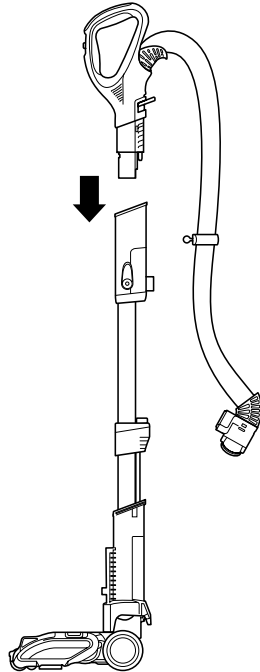

2 Insert handle into wand, pressing it in until it clicks securely into place.

STEP 3

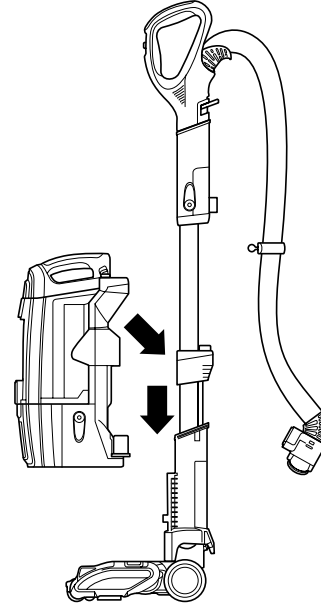

3 Place pod onto wand and slide down to connect.

STEP 4

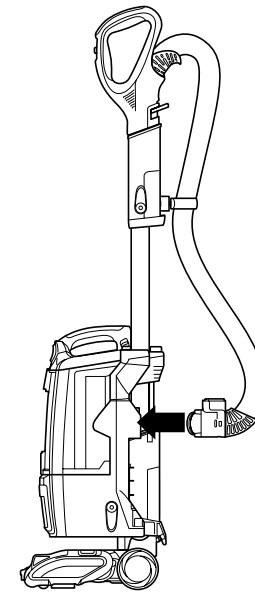

4 Connect hose into back of pod, pressing it in until it clicks securely into place.

STEP 5

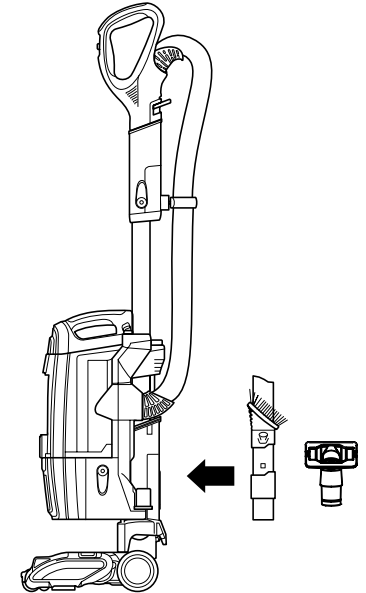

5 Store included accessories on the accessory posts on the pod.

USING YOUR VACUUM IN UPRIGHT MODE

WHAT DOES THE BRUSHROLL INDICATOR LIGHT MEAN?

Solid Green

The brushrolls are spinning and working as they should.

Solid Red

There is a jam in the brushroll area. Turn off your vacuum and remove any blockages.

Flashing Red*

The motorized floor nozzle is overheating. Turn off your vacuum and wait for it to cool down. After vacuum has cooled, move Surface Selector switch to Thick Carpet mode, then press Power button to turn vacuum back on.

No Light

The brushrolls are not spinning because the vacuum is off, the handle may not be tilted back to engage brushrolls, or one part of the vacuum isn't connected correctly.

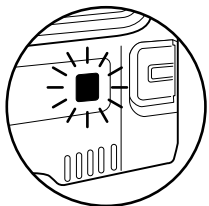

*See Troubleshooting section for further instructions.

STEP 1

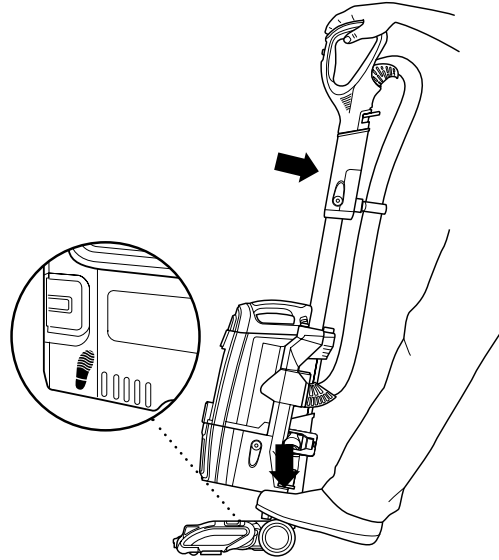

- 1 Plug power cord into outlet. Place foot on floor nozzle and tilt handle back.

STEP 2

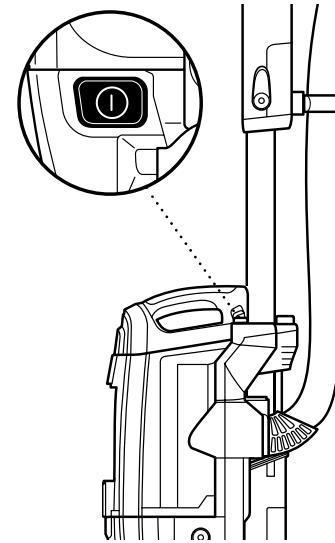

- 2 To start cleaning, press power button to turn on vacuum. Please note the brushrolls will not spin unless the handle is tilted back.

STEP 3

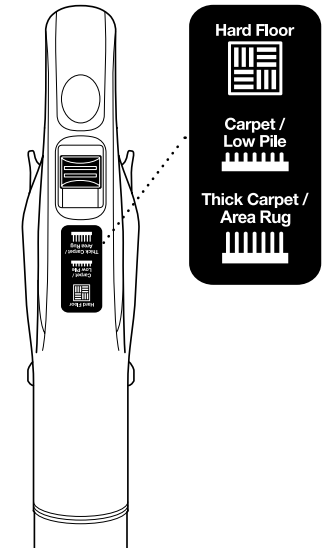

- 3 Choose the appropriate setting.

Hard Floor Cleaning

Set **surface** selector to Hard Floor.

Carpet & Low Pile Cleaning

Set **surface** selector to Carpet/Low Pile. Increases the speed of your brushrolls and can be used to help remove stuck-on dust and debris.

Thick Carpet & Area Rug Cleaning

Set **surface** selector to Thick Carpet/Area Rug.

NOTE: For deep cleaning per ASTM F 608 (embedded dirt in carpets) please set to Carpet/Low Pile.

USING YOUR VACUUM IN ABOVE-FLOOR MODE

STEP 1

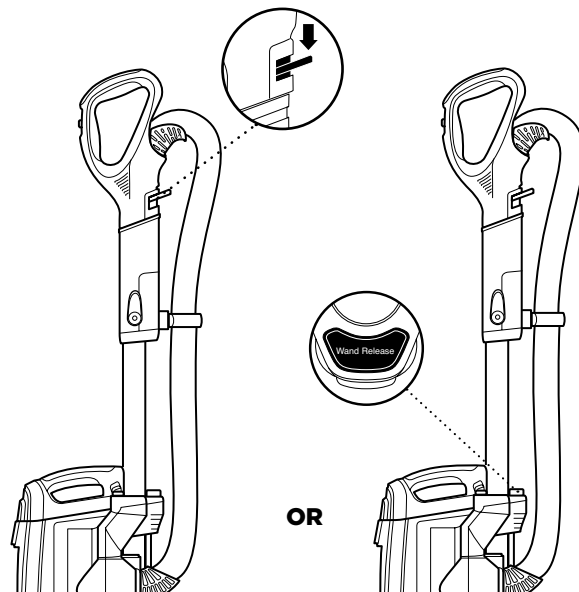

- 1** To clean above-floor areas with the handle, detach it from the wand by pressing the Handle Release button.
- OR** To clean with a longer reach, detach the wand from the floor nozzle by pressing the Wand Release button.

STEP 2

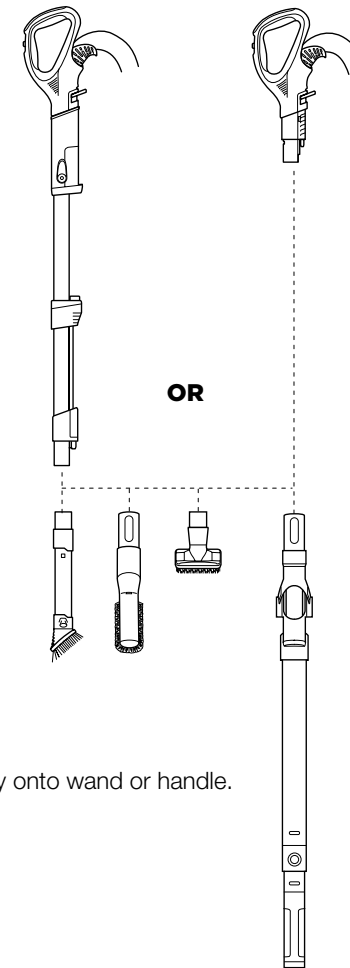

- 2** Attach desired tool directly onto wand or handle.

USING YOUR VACUUM IN POWERED LIFT-AWAY® MODE

⚠ WARNING: Ensure solid footing when using in Lift-Away mode. Using vacuum when you don't have stable footing may result in personal injury.

WHAT IS POWERED LIFT-AWAY?

Our Powered Lift-Away feature allows you to remove the pod from the nozzle while maintaining the same power you have in upright mode. This is great for cleaning stairs, under furniture, and in other tight spaces.

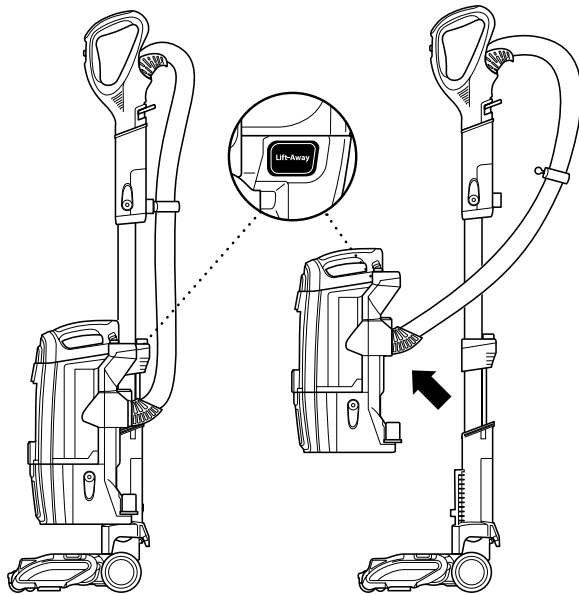

POWERED LIFT-AWAY CLEANING

- 1 Press Lift-Away button to lift pod off floor nozzle. You are now ready to clean hard-to-reach places.

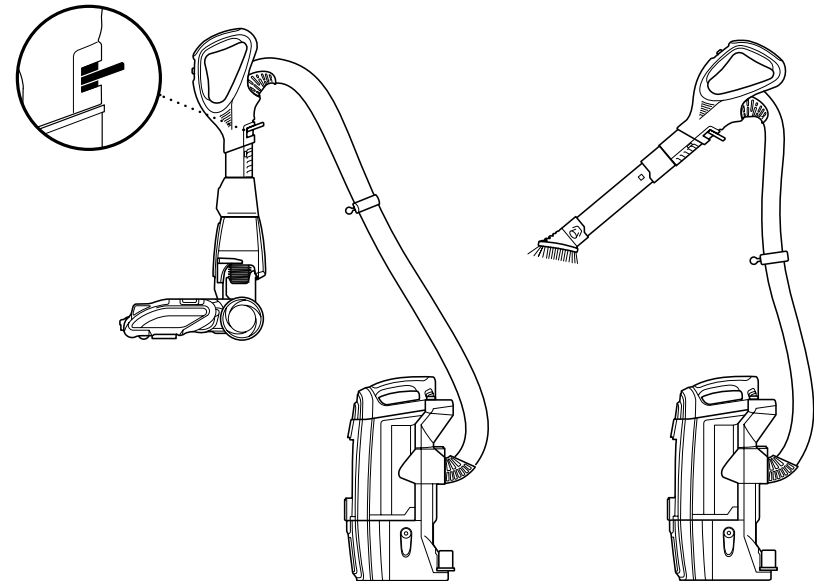

LIFT-AWAY® CLEANING

- 1 Attach desired accessory directly into handle. You can also attach the accessory to the wand for extended reach.

COMPATIBLE ACCESSORIES

There are a variety of accessories that are compatible with this vacuum series.

To purchase additional accessories, visit sharkaccessories.com.

A Pet Multi-Tool

Two tools for cleaning tough pet messes: first, a stiff bristle brush for cleaning stuck-on debris. Then remove the bristles to reveal an upholstery tool for removing stubborn pet hair.

B Duster Crevice

Two cleaning tools in one—the crevice tool gives you extended cleaning reach for small spaces, while the soft dusting brush cleans a multitude of surfaces.

C Anti-Allergen Dust Brush

Nylon fiber bristles specially designed for removing fine dust and allergen particles from the most delicate surfaces.

D MultiFLEX™ Under Appliance Wand

Pivoting wand that extends to clean under appliances and on top of furniture.

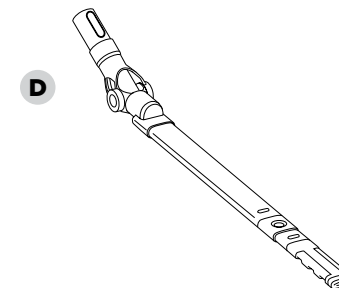
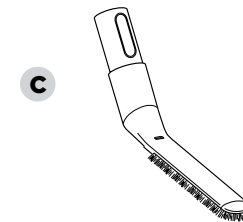
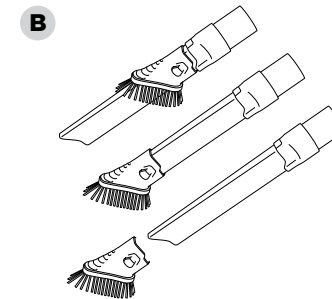
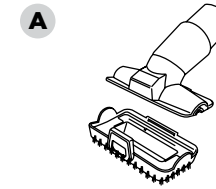

MAINTENANCE

To keep your vacuum's suction power optimal, follow these instructions. Make sure unit is off and cord is unplugged.

⚠ WARNING: To reduce the risk of shock and unintended operation, turn off power and unplug unit before servicing.

⚠ Hand-wash only with water to prevent damage from cleaning chemicals. Allow ALL filters to air-dry completely before replacing them in the vacuum to prevent liquid from being drawn into electric parts.

★ IMPORTANT: DO NOT use soap when cleaning any of the filters.

RECOMMENDED FILTER CLEANING SCHEDULE:

Pre-Motor Filter Kit
XFF680 (Foam & Felt)
Clean every 3 months.

Post-Motor Filters
XPRHF910
(HEPA & Pre-HEPA)
Clean once a year.

STEP 1

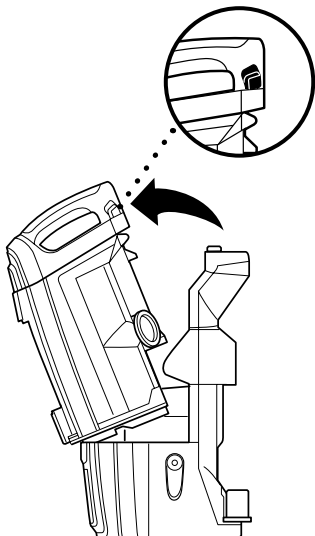

STEP 2

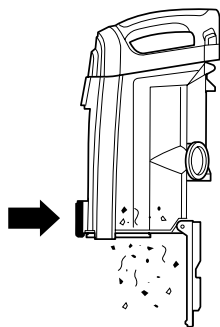

STEP 3

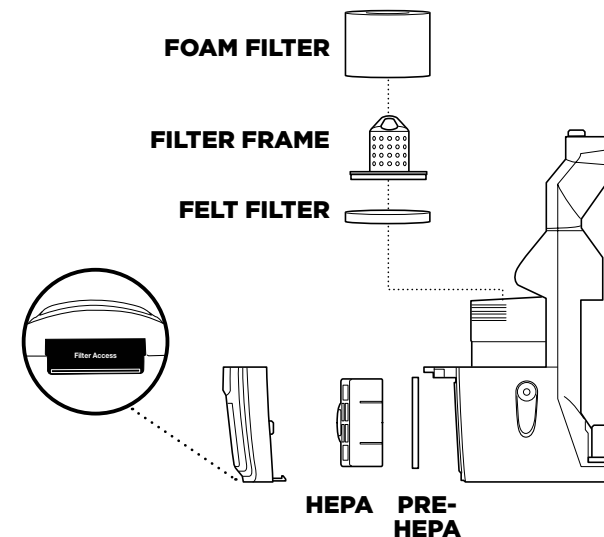
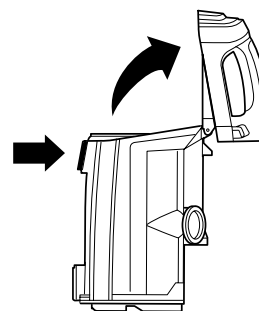

EMPTYING THE DUST CUP

- 1 Pull up on Dust Cup Release Latch and lift dust cup off pod.
- 2 Hold dust cup over a trash bin and press the latch on the bottom of the dust cup to empty it.

- 3 Press top Dust Cup Empty Latch to access dust screen and remove built-up debris as required.

CLEANING THE FILTERS

- 1 **Pre-Motor (foam and felt):** With the dust cup removed, take out the foam and felt filters and rinse them with water. Allow filters to air-dry completely before reinstalling. Tap loose dirt off filters between washes as needed.

- 2 **Post-Motor (HEPA):** To access the HEPA filter, reach under the grill, press the button, and pull the grill away from the vacuum. Remove and rinse the pre-HEPA and HEPA filters. Allow filters to air-dry completely before reinstalling.

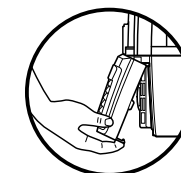

⚠ WARNING: To reduce the risk of shock and unintended operation, turn off power and unplug unit before servicing.

💡 TIP: You can also check for blockages in the hose and tubes. Just remove the floor nozzle, dust cup, and hose, and shine a flashlight in the openings.

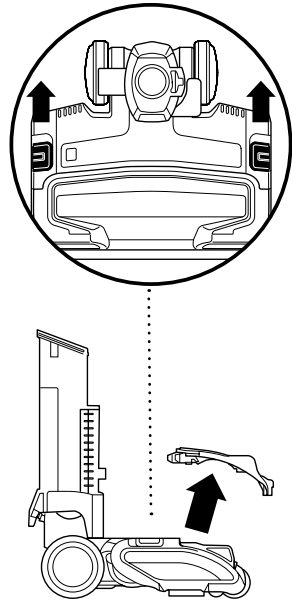

CLEANING THE BRUSHROLL

- 1 Push up both sliders on floor nozzle at the same time to pop up the brushroll garage lid.
- 2 To remove any string, hair, or debris that may be wrapped around the brushroll, use scissors to cut along the groove in the brushroll.

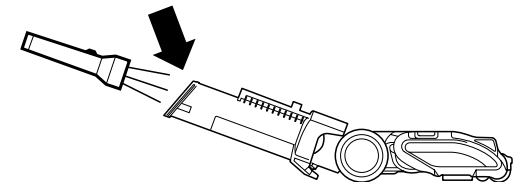
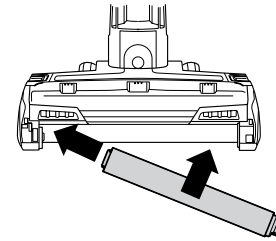
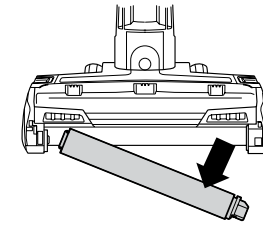

CLEANING THE SOFT ROLLER

- 1 Push up both sliders on floor nozzle at the same time to pop up the brushroll garage lid.
- 2 To remove Soft Roller from nozzle, lift it out by the pull tab on the right side.
- 3 You can also tap loose debris off the Soft Roller, or wipe it clean with a dry towel. If you see any hair buildup or fibers caught in the teeth behind the Soft Roller, wipe clean with a dry towel.
- 4 Wash the Soft Roller as needed. Use only water, and let air-dry completely for at least 24 hours.
- 5 Reinsert Soft Roller until it is secured, then place the garage door lid onto the nozzle and press down until it securely clicks in place on both sides.

CHECKING THE NOZZLE FOR BLOCKAGES

- 1 Tilt neck of nozzle back to straighten the airway, then remove any blockages from nozzle.

⚠ WARNING: To reduce the risk of shock and unintended operation, turn power off and unplug unit before servicing.

This vacuum nozzle is specifically designed to pull in all types of debris and therefore can give the feeling of being self-propelled, especially on short carpets. If you'd like to feel less pull forward when using, you can change the handle mode setting from Carpet/Low Pile to either Hard Floor (for slower brush speed) or Thick Carpet/Area Rug (for less suction).

Vacuum is not picking up debris. No suction or light suction. (Refer to Maintenance section for more information.)

- Dust cup may be full; empty dust cup.
- Check hose, hose connections, nozzle, and accessories for blockages; clear blockages if required.
- Remove any string, carpet fibers, or hair that may be wrapped around the brushrolls.
- Check filters to see if they need cleaning. Refer to pg. 18 for proper maintenance instructions.

Vacuum lifts area rugs.

- Turn off unit to disengage the brushrolls. Be sure to select Thick Carpet/Area Rug setting.
- Suction is powerful. Take care when vacuuming area rugs or rugs with delicately sewn edges.

Brushroll and/or Soft Roller does not spin or the Brushroll Indicator Light turns red.

- Turn off vacuum, and move it away from any obstruction. Turn on vacuum and tilt handle back to activate brushroll.
- If Brushroll Indicator Light on floor nozzle remains red, turn off vacuum and unplug. Disconnect nozzle and remove any blockages. Make sure brushroll garage lid is firmly locked into position on both sides. Plug in vacuum, turn on power, and tilt handle back to activate brushroll. If Brushroll Indicator Light isn't green and headlights are flashing, check again that both sides of lid are locked in place.
- If the Brushroll Indicator Light is still red, please contact Customer Service at 1-800-798-7398.

The Brushroll Indicator Light on the floor nozzle doesn't light up (either green or red) when you tilt the handle back.

- Turn off and unplug the unit. The Brushroll Indicator Light will not turn on if one part of the vacuum is not properly connected. **Detach hose, handle, and wand, then reattach them, making sure that each clicks securely into place.** After the unit is reassembled, turn on and tilt handle back to activate brushroll.
- If the Brushroll Indicator Light still doesn't light up, please contact Customer Service at 1-800-798-7398.

The 7-Year Limited Warranty applies to purchases made from authorized retailers of **SharkNinja Operating LLC**. Warranty coverage applies to the original owner and to the original product only and is not transferable.

SharkNinja warrants that the unit shall be free from defects in material and workmanship for a period of 7 years from the date of purchase when it is used under normal household conditions and maintained according to the requirements outlined in this instruction manual, subject to the following conditions and exclusions.

What is covered in my warranty?

1. The original unit and/or non-wearable components deemed defective, in SharkNinja's sole discretion, will be repaired or replaced for up to 7 years from the original purchase date.
2. In the rare event that a replacement unit is issued, the warranty coverage ends six months following the receipt date of the replacement unit or the remainder of the existing warranty, whichever is greater. If the unit is replaced, SharkNinja reserves the right to replace the unit with one of equal or greater value.

What is not covered in my warranty?

Our Customer Service/Product Specialists are available to provide all the warranty service options available to you, including the possibility of upgrading to our VIP Warranty Service Options for select product categories.

1. Normal wear and tear of wearable parts such as foam filters, HEPA filters, pads etc., which require regular maintenance and/or replacement to ensure the proper functioning of your unit are not covered by this warranty.
2. Any unit that has been tampered with or used for commercial purposes.
3. SharkNinja will cover the cost for the customer to send in the unit to us for repair or replacement. A fee of \$19.95 for return shipping costs will be charged at the time of return shipment of the repaired or replacement unit.
4. Damage caused by misuse, abuse, or negligent handling, or damage due to mishandling in transit.
5. Consequential and incidental damages.
6. Defects caused by or resulting from damages from shipping or from repairs, service, or alteration to the product or any of its parts which have been performed by a repair person not authorized by SharkNinja.
7. Products purchased, used or operated outside of North America.

Problems with your unit/How to get service

If your appliance fails to operate properly while in use under normal household conditions within the warranty period, visit sharkclean.com for product care/maintenance self-help. Our Customer Service and product specialists are also available at 1-800-798-7398 to assist with product support and warranty service options.

How to initiate a warranty claim

You can call 1-800-798-7398 to have a Customer Service specialist assist you. Please note you must call 1-800-798-7398 to initiate a warranty claim. Return and Packing Instruction information will be provided at that time.

For Customer Service hours, visit sharkclean.com.

Replacement parts are available for purchase at sharkclean.com. For more information on which parts are classified as wearable and non-wearable, please visit sharkclean.com/warranty.

This warranty gives you specific legal rights, and you also may have other rights that vary from state to state.

Some states do not permit the exclusion or limitation of incidental or consequential damages, so the above may not apply to you.



SharkNinja Operating LLC
US: Needham, MA 02494
CAN: Ville St-Laurent, QC H4S 1A7
1-800-798-7398
sharkclean.com

Illustrations may differ from actual product. We are constantly striving to improve our products, therefore the specifications contained herein are subject to change without notice.

DUOCLEAN, LIFT-AWAY, POWERED LIFT-AWAY, and SHARK are registered trademarks of SharkNinja Operating LLC.

APEX, MULTIFLEX, and POWERED LIFT-AWAY SPEED are trademarks of SharkNinja Operating LLC.

For SharkNinja U.S. Patent information visit sharkninja.com/USPatents.

© 2018 SharkNinja Operating LLC
QU922Q_Series_IB_Mv2
PRINTED IN CHINA / IMPRIMÉ EN CHINE / IMPRESO EN CHINA



@sharkcleaning